

A SECTION - CONDUIT LAYOUT

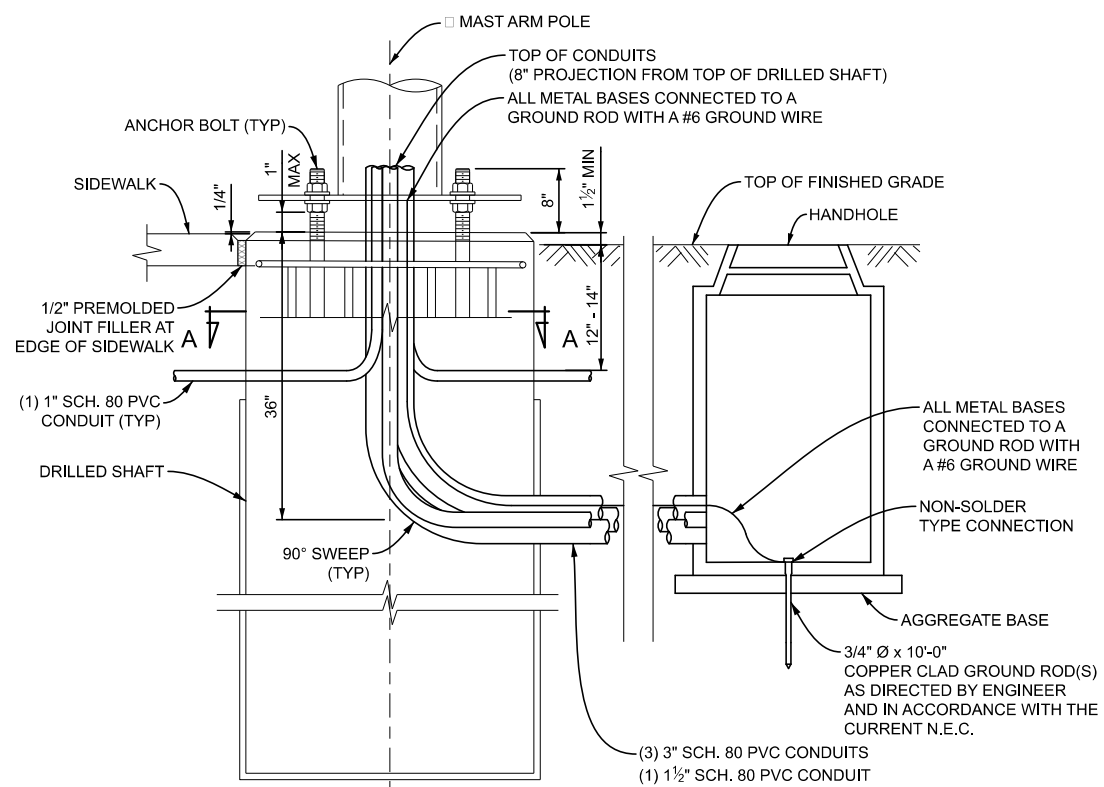

1 DETAIL - CONDUIT LAYOUT AND GROUNDING

NOTES:

1. ALL GROUND RODS SHALL BE 3/4" X 10' COPPER CLAD ROD. A MINIMUM OF 2 GROUND RODS SHALL BE USED (ONE FOR THE SERVICE DISCONNECT AND ONE FOR THE MESSENGER CABLE & POLE).
2. GROUND ROD PLACEMENT SHALL NOT BE LESS THAN 12" FROM THE FOUNDATION WITH A MINIMUM OF 6' BETWEEN GROUND RODS. PLACEMENT SHALL BE AS DIRECTED BY THE ENGINEER AND IN COMPLIANCE WITH N.E.C.
3. GROUND WIRE CONNECTION TO GROUNDING ROD(S) SHALL UTILIZE A NON-SOLDER TYPE CONNECTION.
4. INDICATE THE DIRECTION OF CONDUITS IN FOUNDATION TOP WITH AN ARROW.
5. INSTALL POLE SUCH THAT THE FOUNDATION & ANCHOR BOLTS ARE PLUMB.
6. ALL GROUNDS SHALL PROVIDE LESS THAN 10 OHM RESISTANCE TO GROUND.

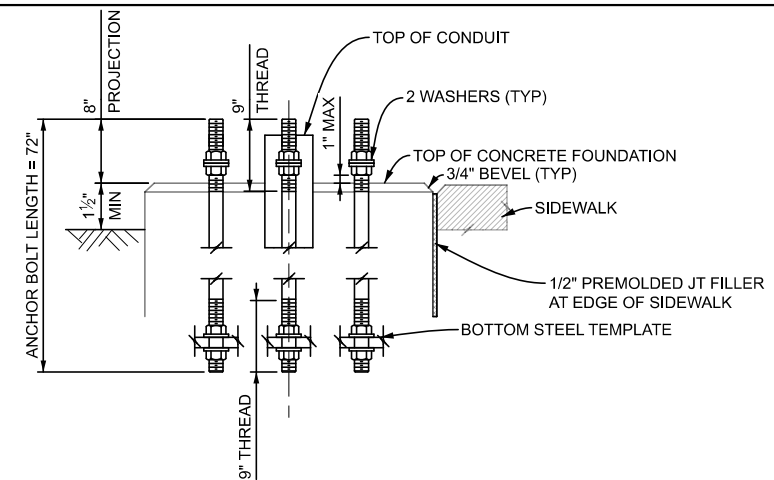

TRENCH FOR PLACEMENT OF CONDUITS AFTER CASING IS IN PLACE AND BEFORE DEWATERING.

2 DETAIL - ANCHOR BOLTS

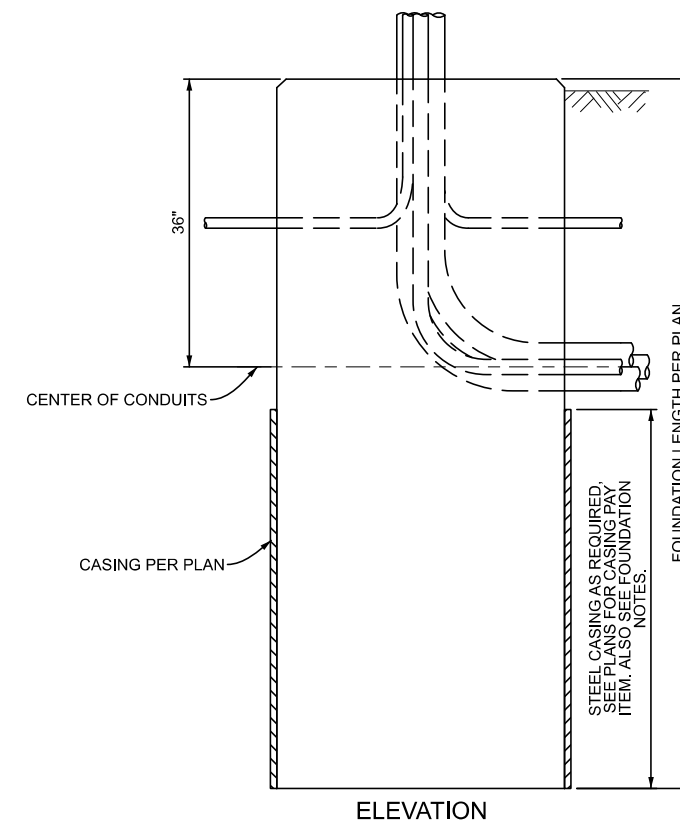
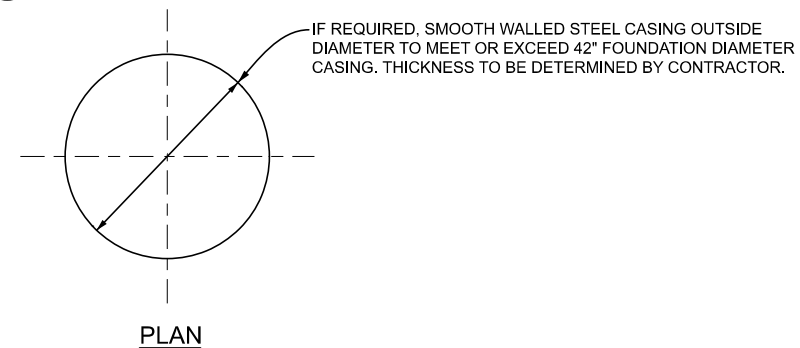

ELEVATION

APPROVED BY: _____
DIRECTOR, BUREAU OF FIELD SERVICES



APPROVED BY: _____
DIRECTOR, BUREAU OF DEVELOPMENT

DEPARTMENT DIRECTOR
BRADLEY C. WIEFERICH, PE

STANDARD PLAN FOR
TRAFFIC SIGNAL MAST ARM
STANDARD FOUNDATIONS

(SPECIAL DETAIL)
FHWA APPROVAL

07/27/23
PLAN DATE

SIG-040-B

SHEET
1 OF 4



DEPARTMENT DIRECTOR
BRADLEY C. WIEFERICH, PE

(SPECIAL DETAIL)
FHWA APPROVAL

07/27/23
PLAN DATE

STANDARD PLAN FOR
DRILLED FOUNDATION SHAFT
(SHOWN WITH CASING PAY ITEM)

SIG-040-B

SHEET
2 OF 4

SECT

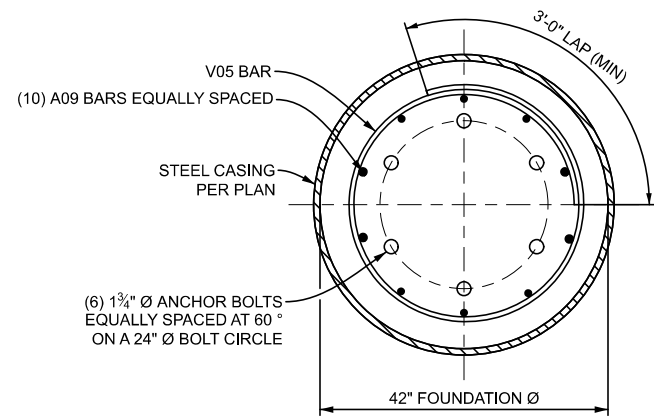

B SECTION - FOUNDATION PLAN

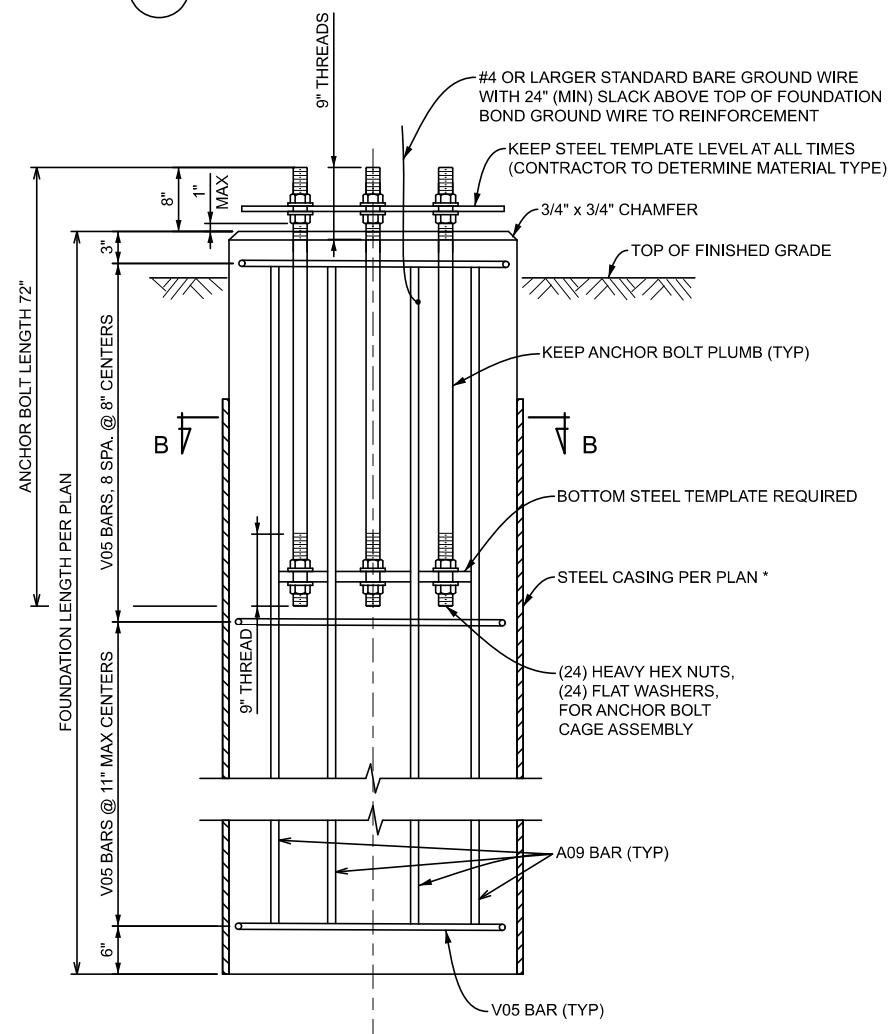

4 DETAIL - MAST ARM FOUNDATION ELEVATION SHOWN WITH CASING PAY ITEM

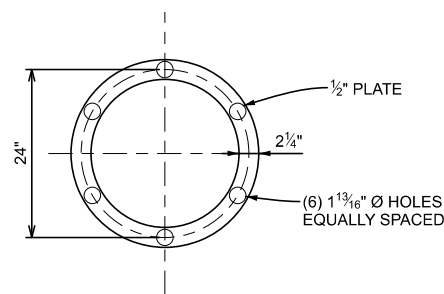

3 DETAIL - BOTTOM STEEL TEMPLATE

FOUNDATION NOTES:

1. TEMPLATES SHALL BE SHOP FABRICATED AND ASSEMBLED PRIOR TO BEING APPROVED BY MDOT FOR SHIPPING.
2. DIAMETER OF BOLT HOLES IN TEMPLATE SHALL BE 1/16" LARGER THAN ANCHOR BOLT DIAMETER.
3. MAST ARM ORIENTATION IS NOT DEPENDENT ON ANCHOR BOLT POSITION.
4. CONDUITS AND ANCHOR BOLTS SHALL BE RIGIDLY INSTALLED BEFORE CONCRETE IS PLACED. THE CENTER OF THE TEMPLATE SHALL COINCIDE WITH THE CENTER OF THE FOUNDATION. THE TEMPLATE AND HANDLES SHALL BE WELL SUPPORTED, HORIZONTALLY LEVEL, HELD VERTICAL AT THE PROPER ELEVATION, AND FIRMLY ANCHORED IN PLACE A MINIMUM OF 24 HOURS AFTER THE CONCRETE PLACEMENT IS COMPLETED.
5. DUE CARE SHALL BE TAKEN DURING THE CONCRETE PLACEMENT TO AVOID DISPLACING THE ANCHOR BOLTS.
6. NO HAMMERING ON THE ANCHOR BOLTS OR TEMPLATE WILL BE ALLOWED.
7. AFTER TEMPLATE IS REMOVED, THREAD NUTS ON TO THE BOLT FLUSH WITH THE BOLT END TO PROTECT THREADS UNTIL SIGNAL SUPPORT IS ERECTED.
8. GALVANIZE ALL EXPOSED NUTS, BOLTS, AND WASHERS ACCORDING TO ASTM F2329. GALVANIZE ALL OTHER STEEL ITEMS ACCORDING TO ASTM A123. EMBEDDED NUTS, BOLTS, WASHERS, AND BOTTOM STEEL TEMPLATE NEED NOT BE GALVANIZED.
9. FOR ANCHOR BOLT MATERIAL, REFER TO SECTION 908.14 A AND B OF THE MICHIGAN STANDARD SPECIFICATIONS FOR CONSTRUCTION. FOR ANCHOR BOLT INSTALLATION AND TIGHTENING, REFER TO SECTION 810.03 N.
10. IF SOIL CONDITIONS INDICATE THERE IS NO NEED FOR A CASING PAY ITEM AS SHOWN ON THE PLANS, THE CONTRACTOR SHOULD REQUEST PERMISSION OF THE ENGINEER TO INSTALL THE FOUNDATION WITHOUT CASING.
11. WHEN THE CASING PAY ITEM IS INCLUDED ON THE PLANS FOR A FOUNDATION (DUE TO GRANULAR SOILS, A WET HOLE OR OTHER UNSTABLE CONDITIONS), STEEL CASING (SMOOTH WALLED) IS TO BE INSTALLED TO ENABLE THE FOUNDATION TO BE POURED. THE THICKNESS OF THE STEEL IS TO BE DETERMINED BY THE CONTRACTOR. THE STEEL CASING SHALL BE LEFT IN PLACE. IF SOIL EXTENDING LATERALLY WITHIN 6 FEET OF THE DRILLED SHAFT FOUNDATION IS LOOSENEED OR OTHERWISE DISTURBED, SCARIFY MATERIAL AT THE BASE OF THE EXCAVATION BELOW THE DEPTH OF DISTURBANCE AND RECOMPACT IN ACCORDANCE WITH 206.03.B OF THE MDOT STANDARD SPECIFICATIONS FOR CONSTRUCTION. COMPACT ALL BACKFILL PLACED ABOVE THE RECOMPACTED BASE OF EXCAVATION IN ACCORDANCE WITH 206.03.B OF THE MDOT STANDARD SPECIFICATIONS FOR CONSTRUCTION.
12. WHEN THE CASING PAY ITEM IS CALLED FOR ON THE PLANS, THE STEEL CASING MAY STOP AT THE CONDUIT ENTRANCE TO FOUNDATION. TOP OF FOUNDATION MUST THEN BE FORMED SEPARATELY. THE CASING PAY ITEM QUANTITY WILL BE PAID FOR BASED ON ACTUAL LINEAR FEET INSTALLED.
13. CONSTRUCT MAST ARM FOUNDATIONS, ACCORDING TO SUBSECTIONS 718.03 OF THE STANDARD SPECIFICATIONS FOR CONSTRUCTION. ALL WORK AND MATERIALS SHALL BE IN ACCORDANCE WITH THE MDOT STANDARD SPECIFICATIONS.
14. STEEL REINFORCEMENT SHALL BE ASTM A615 GRADE 60 WITHOUT EPOXY COATING.
15. EXPOSED CONCRETE SURFACES SHALL BE CAST IN FORMS. EXPOSED CONCRETE EDGES SHALL BE BEVELED 3/4".
16. GROUNDING OF POLE INCLUDES ADDING #4 BARE COPPER GROUND WIRE BONDED BY MECHANICAL CONNECTION TO FOUNDATION REINFORCING STEEL AND HAVING 24" OF SLACK ABOVE THE TOP OF FOUNDATION.

 DEPARTMENT DIRECTOR BRADLEY C. WIEFERICH, PE	STANDARD PLAN FOR MAST ARM FOUNDATION (SHOWN WITH CASING PAY ITEM)			SHEET 3 OF 4
	(SPECIAL DETAIL) FHWA APPROVAL	07/27/23 PLAN DATE	SIG-040-B	

 DEPARTMENT DIRECTOR BRADLEY C. WIEFERICH, PE	STANDARD PLAN FOR FOUNDATION NOTES			SHEET 4 OF 4 SECT
	(SPECIAL DETAIL) FHWA APPROVAL	07/27/23 PLAN DATE	SIG-040-B	