

ISOMETRIC VIEW

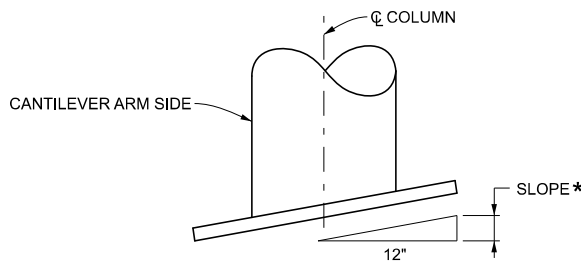
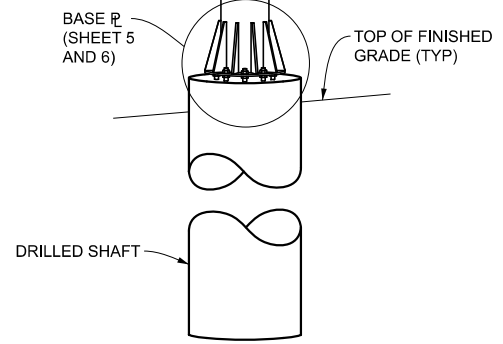

COLUMN BASE CUTTING DETAIL

* CUT PIPE BOTTOM TO PROVIDE FOR COLUMN RAKING PER TABLE BELOW

CANTILEVER TRUSS DATA			
CANTILEVER ARM LENGTH (FT)	NUMBER OF PANELS	SUPPORT END PANEL LENGTH (FT)	SLOPE (IN)
40	4	2 @ 10.0	1/8
35	4	2 @ 7.5	1/8
30	3	2 @ 10.0	1/8
25	3	2 @ 7.5	1/16
20	2	2 @ 10.0	1/16

NOTE:
CANTILEVER "TYPE J" CAN ONLY BE USED WITH WRITTEN AUTHORIZATION FROM THE MDOT TRAFFIC AND SAFETY SUPPORT AREA.

APPROVED BY: _____
DIRECTOR, BUREAU OF FIELD SERVICES

APPROVED BY: _____
DIRECTOR, BUREAU OF DEVELOPMENT



DEPARTMENT DIRECTOR
BRADLEY C. WIEFERICH, PE

STANDARD PLAN FOR
STEEL TRUSS TYPE J
(20FT - 40FT)

(SPECIAL DETAIL) 08/08/23
FHWA APPROVAL PLAN DATE

SIGN 370-C

SHEET
1 OF 10

NOTES:

1. THE DESIGN OF THIS STRUCTURE IS BASED ON THE AASHTO LRFD STANDARD FOR SPECIFICATIONS FOR STRUCTURAL SUPPORTS FOR HIGHWAY SIGNS, LUMINAIRES, AND TRAFFIC SIGNALS, FIRST EDITION (2015), WITH 2017 TO 2022 INTERIM REVISIONS.
2. WELDING MUST BE IN ACCORDANCE WITH AWS D1.1 AS SPECIFIED IN 20SP-707A, STRUCTURAL STEEL AND ALUMINUM CONSTRUCTION.
3. ONLY TYPE I SIGNS ARE TO BE USED WITH THE TYPE J CANTILEVER.
4. MAXIMUM SIGN AREA IS 450 SQUARE FEET. SIGNS MUST NOT PROJECT PAST THE ENDS OF THE TRUSS. MAXIMUM 6 FOOT SIGN PROJECTION ABOVE THE TOP CHORD. MINIMUM SIGN HEIGHT WITH ALUMINUM BEAM IS 8.5 FEET.
5. GALVANIZING OF BOLT ASSEMBLIES SHALL BE IN ACCORDANCE WITH SUBSECTIONS 919.07.I AND 906.07 OF THE MDOT STANDARD SPECIFICATIONS FOR CONSTRUCTION.
6. PROVIDE $1\frac{5}{16}$ " \emptyset HOLES FOR $\frac{7}{8}$ " \emptyset HIGH STRENGTH (HS) BOLTS FOR ALL CONNECTIONS UNLESS OTHERWISE STATED. PROVIDE HIGH STRENGTH BOLTS, NUTS, AND WASHERS IN ACCORDANCE WITH SUBSECTION 906.07 OF THE MDOT STANDARD SPECIFICATIONS FOR CONSTRUCTION. PROVIDE LOCK WASHERS THAT MEET ASME B18.21.1.
7. TIGHTEN ALL HIGH STRENGTH BOLTS BY THE TURN OF THE NUT METHOD PER SUBSECTION 707.03.E.6 OF THE MDOT STANDARD SPECIFICATIONS FOR CONSTRUCTION.
8. DO NOT LIFT THE TRUSS BY THE WEB MEMBERS.
9. FIELD SPLICES MAY BE PLACED ALONG THE TRUSS CHORD TO FACILITATE FABRICATION. PLACE FIELD SPLICE \geq 1'-6" MINIMUM TO THE GUSSET PLATE EDGE. ANY DEVIATION FROM THE DETAILS SHOWN ON THIS TYPICAL WILL REQUIRE APPROVAL BY THE ENGINEER IN WRITING BEFORE FABRICATION.
10. ALL WELDS MUST BE INSPECTED IN ACCORDANCE WITH SUBSECTION 707.03.D.12 OF THE STANDARD SPECIFICATIONS FOR CONSTRUCTION, EXCEPT MINIMUM MT INSPECTION FREQUENCY IS INCREASED TO 25 PERCENT.
11. SEE CURRENT MDOT SIGN SUPPORT TYPICAL PLAN SIGN-350-SERIES FOR SIGN FOUNDATION.
12. SEE CURRENT MDOT SIGN SUPPORT TYPICAL PLAN SIGN-700-SERIES FOR SIGN CONNECTION.
13. COLUMN SECTION MUST BE ASTM A53, GRADE B OR API-5L-X42 24" X 1.219". CHORD SECTIONS MUST BE ASTM A500, GRADE B HSS 10.75" \emptyset X 0.625", ASTM 519-4140 ANNEALED HSS 10" \emptyset X 0.500".
14. WEB ANGLES MUST BE ASTM A709, GRADE 36 OR ASTM A36 L5X5X $\frac{7}{16}$ OR L5X5X $\frac{1}{2}$. STEEL PLATES MUST BE ASTM A709, GRADE 36 OR 50, ASTM A36, OR ASTM A572 GRADE 50.
15. THE ESTIMATED WEIGHT OF THE TRUSS IS 190 POUNDS PER FOOT.
16. BASE PLATE (ρ) WARPAGE MUST NOT EXCEED $\frac{1}{16}$ INCH PER FOOT.
17. CHARPY V-NOTCH TESTING IS REQUIRED FOR THE COLUMN UPRIGHT IN ACCORDANCE WITH THE AASHTO LRFD SPECIFICATIONS FOR STRUCTURAL SUPPORTS FOR HIGHWAY SIGNS, LUMINAIRES, AND TRAFFIC SIGNALS, FIRST EDITION (2015), WITH 2017 TO 2022 INTERIM REVISIONS.
18. SELECT SEALANT FOR PERIMETER OF BACKING BAR PLATE FROM THE QUALIFIED PRODUCTS LIST. PROVIDE SEALANT IN CAULKING TUBES.



DEPARTMENT DIRECTOR
BRADLEY C. WIEFERICH, PE

STANDARD PLAN FOR
STEEL TRUSS TYPE J
(20FT - 40FT)

(SPECIAL DETAIL)
FHWA APPROVAL

08/08/23
PLAN DATE

SIGN 370-C

SHEET
2 OF 10

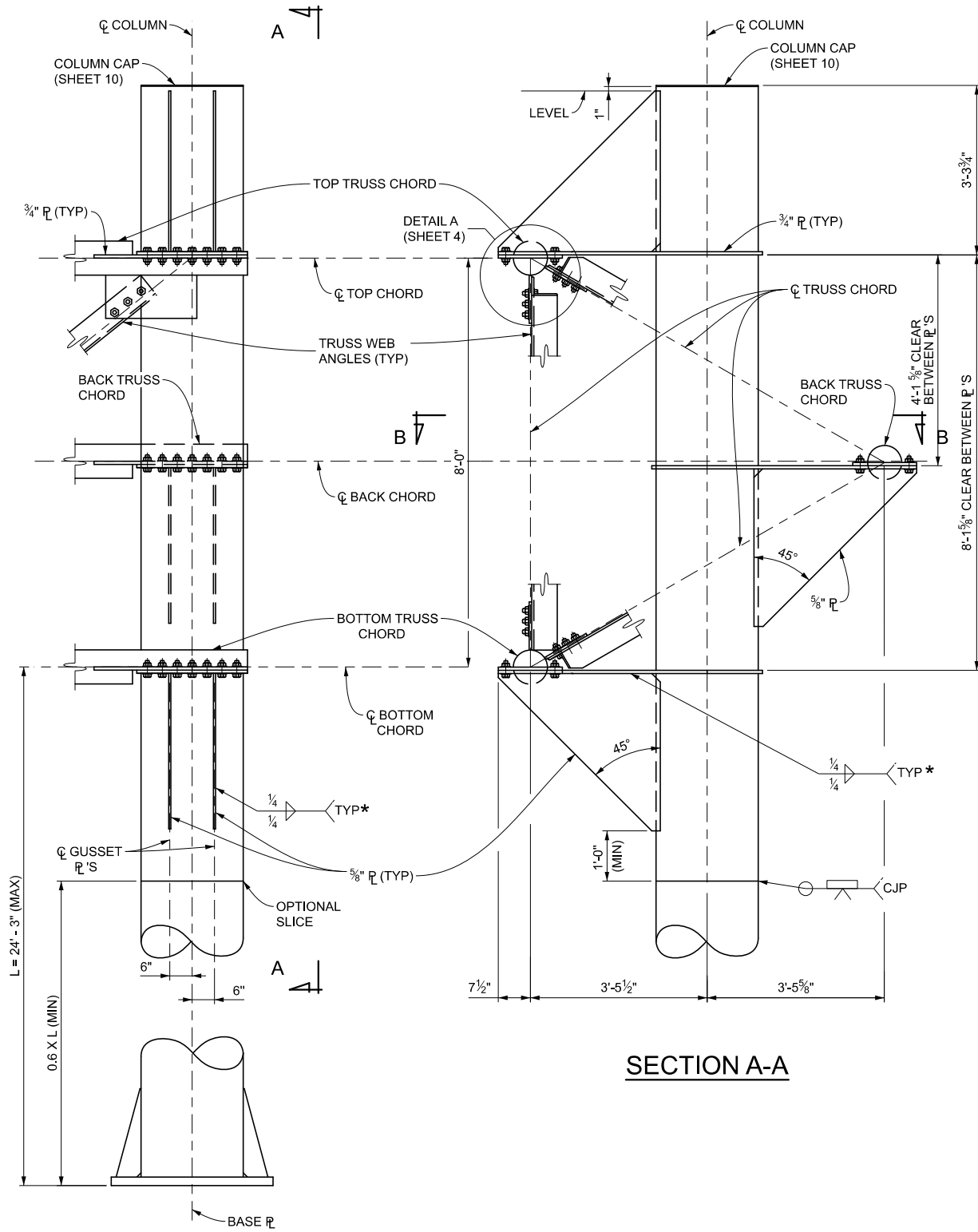

SECTION A-A

COLUMN TRUSS CONNECTION DETAIL

(WEB MEMBERS AND CONNECTION PLATES OMITTED FOR CLARITY)

* WRAP WELD AROUND OUTSIDE EDGE, STOP 1/4" SHORT OF CORNER CLIP

<p>DEPARTMENT DIRECTOR BRADLEY C. WIEFERICH, PE</p>	<p>STANDARD PLAN FOR STEEL TRUSS TYPE J (20FT - 40FT)</p>		<p>SHEET 3 OF 10</p>
	<p>(SPECIAL DETAIL) FHWA APPROVAL</p>	<p>08/08/23 PLAN DATE</p>	

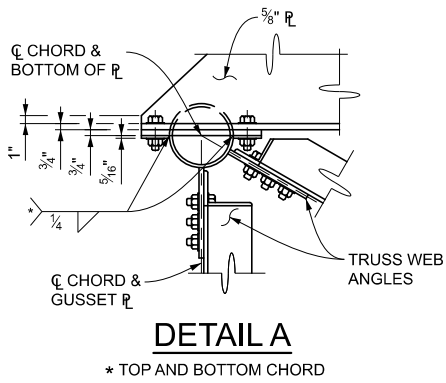

DETAIL A

* TOP AND BOTTOM CHORD

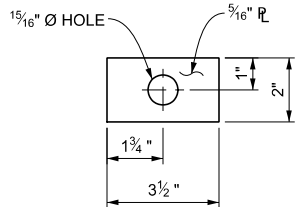
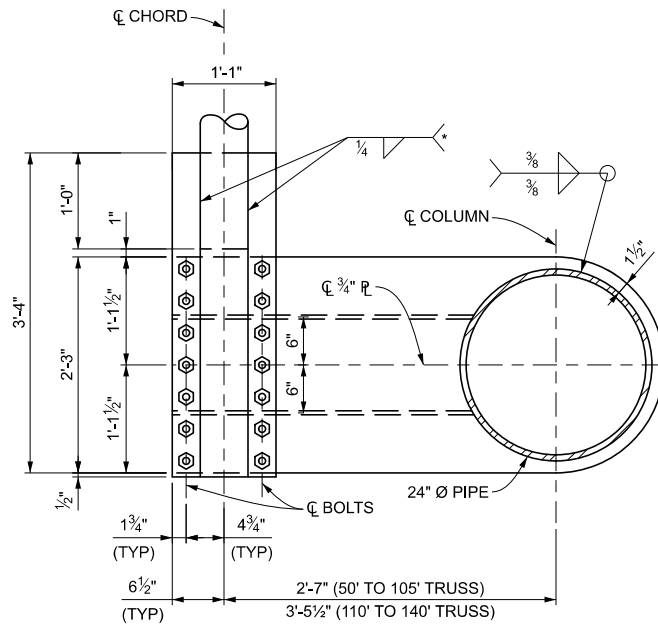
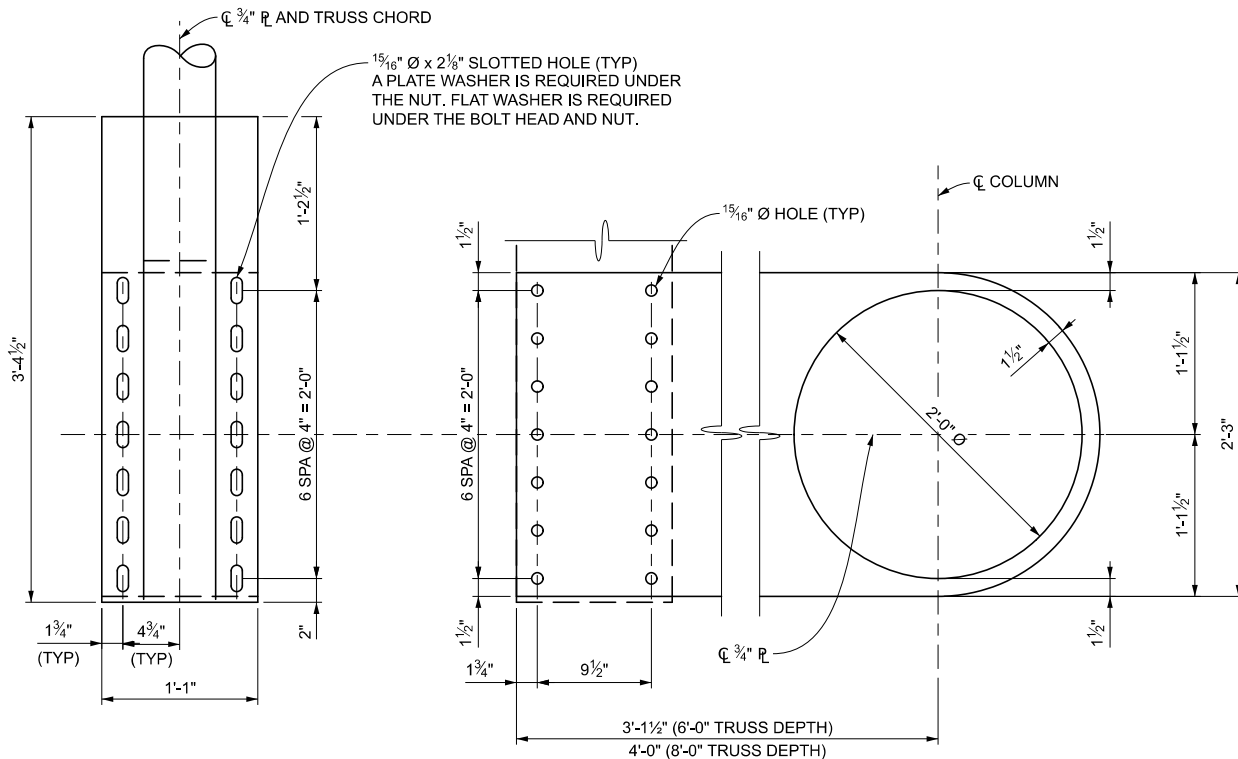

PLATE WASHER DETAIL



SECTION B-B

WEB MEMBERS AND CONNECTION PLATES OMITTED FOR CLARITY.
TOP CHORD SIMILAR
* TOP AND BOTTOM CHORD



CHORD-COLUMN CONNECTION PLATE DETAILS



DEPARTMENT DIRECTOR
BRADLEY C. WIEFERICH, PE

STANDARD PLAN FOR
STEEL TRUSS TYPE J
(20FT - 40FT)

(SPECIAL DETAIL)
FHWA APPROVAL

08/08/23
PLAN DATE

SIGN 370-C

SHEET
4 OF 10

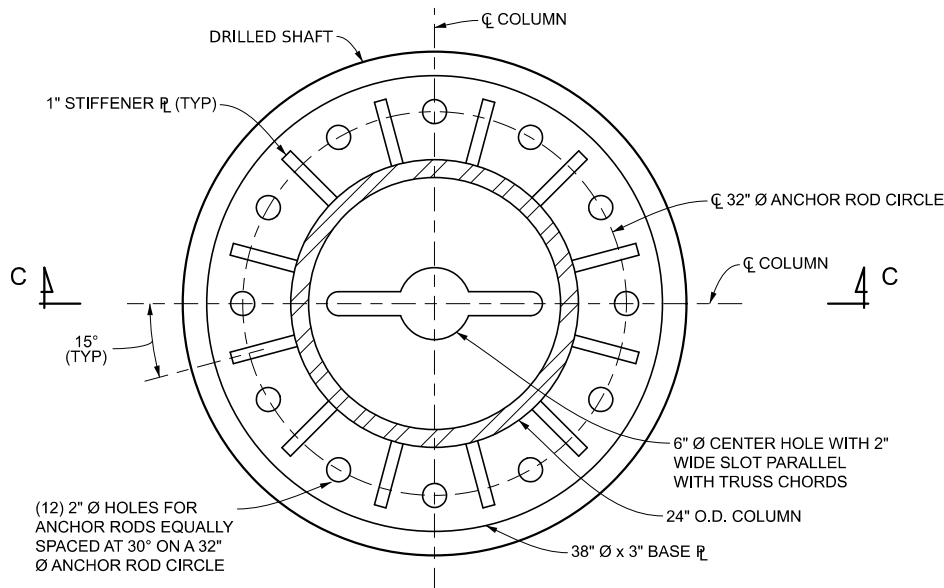

PLAN VIEW 38" BASE PLATE DETAIL

FOR USE WITH 20 FT, 25 FT, AND 30 FT CANTILEVER ARMS.

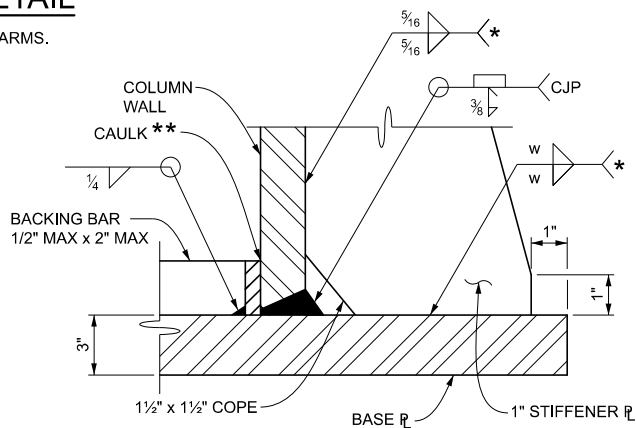

DETAIL B

* WRAP WELD AROUND OUTSIDE
EDGE STOP 1/4" SHORT OF CORNER CLIP
** CAULK UNWELDED JOINT BETWEEN
BACKING BAR AND COLUMN WALL AFTER HDG.

W = 5/8" FOR 38" BASE PLATE
3/8" FOR 42" BASE PLATE

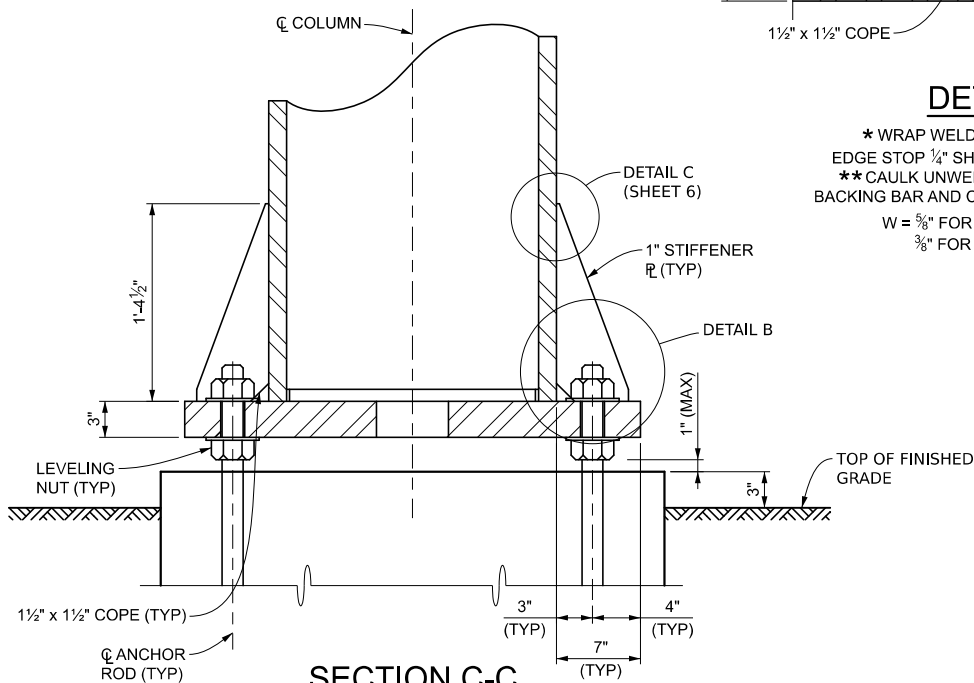

SECTION C-C

ELEVATION VIEW FOR 30' BASE PLATE



DEPARTMENT DIRECTOR
BRADLEY C. WIEFERICH, PE

STANDARD PLAN FOR
STEEL TRUSS TYPE J
(20FT - 40FT)

(SPECIAL DETAIL)
FHWA APPROVAL

08/08/23
PLAN DATE

SIGN 370-C

SHEET
5 OF 10

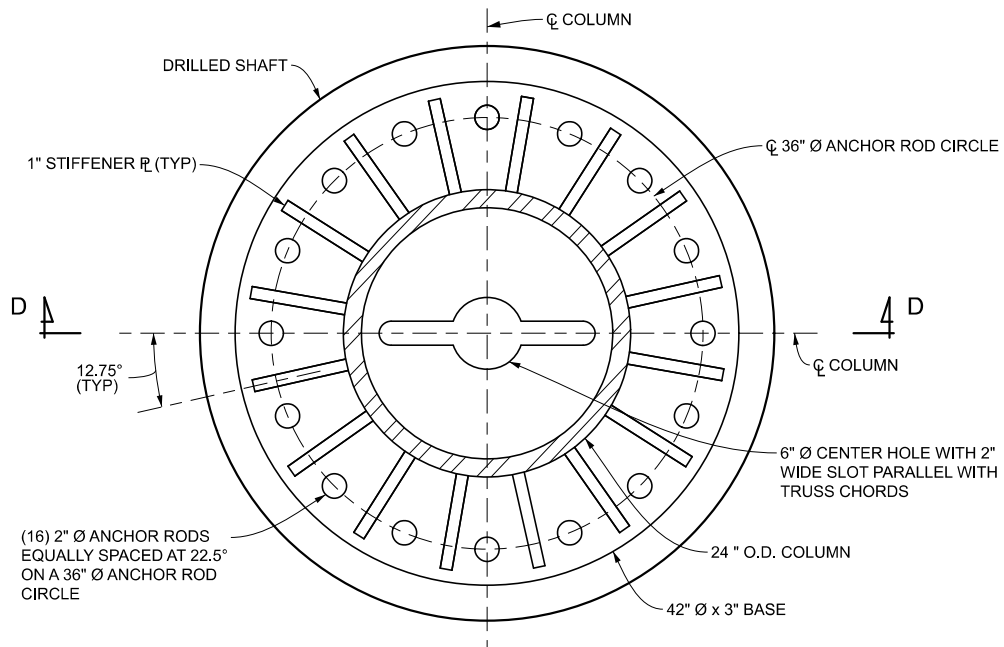

PLAN VIEW 42" BASE PLATE DETAIL

FOR USE WITH 35 FT AND 40 FT CANTILEVER ARMS

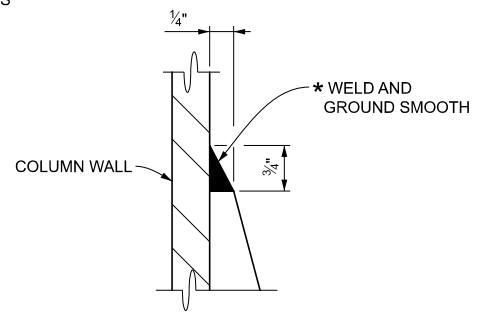

DETAIL C

* GRIND TO 250 RMS OR SMOOTHER PER AWS D1.1

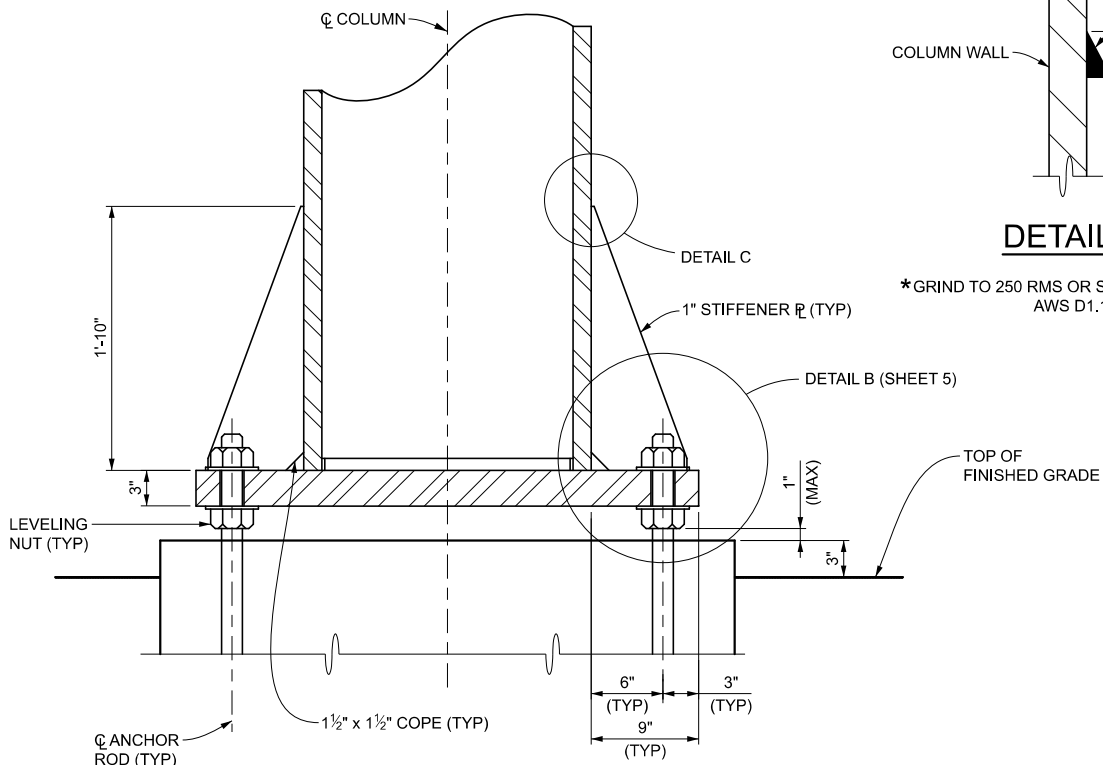

SECTION D-D

ELEVATION VIEW FOR 42" BASE PLATE



DEPARTMENT DIRECTOR
BRADLEY C. WIEFERICH, PE

STANDARD PLAN FOR
STEEL TRUSS TYPE J
(20FT - 40FT)

(SPECIAL DETAIL)
FHWA APPROVAL

08/08/23
PLAN DATE

SIGN 370-C

SHEET
6 OF 10

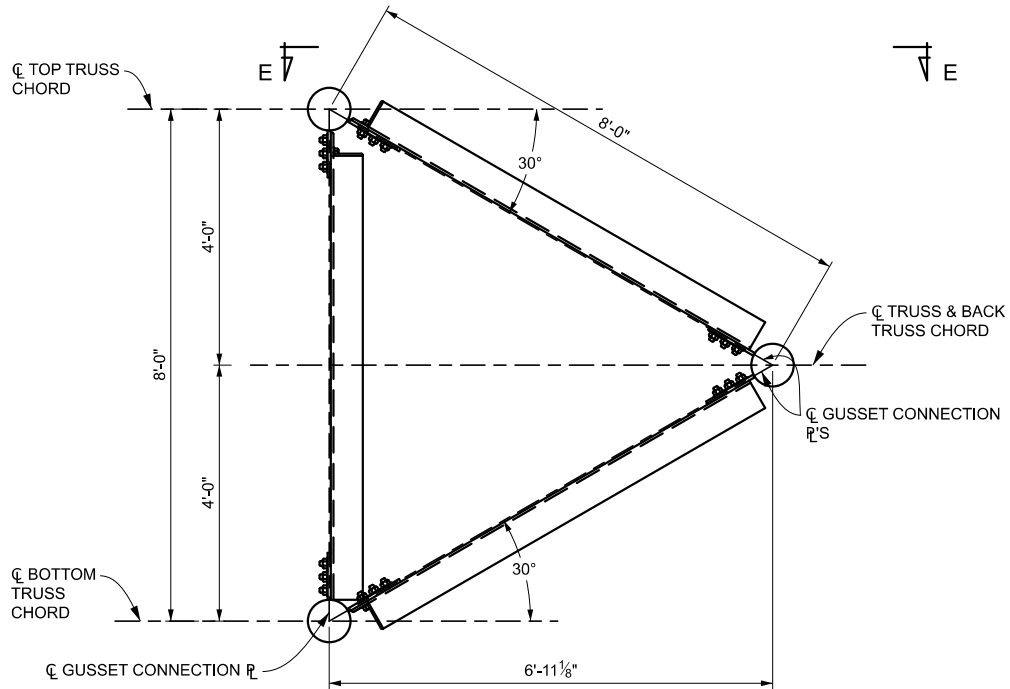

TYPICAL SECTION OF TRUSS

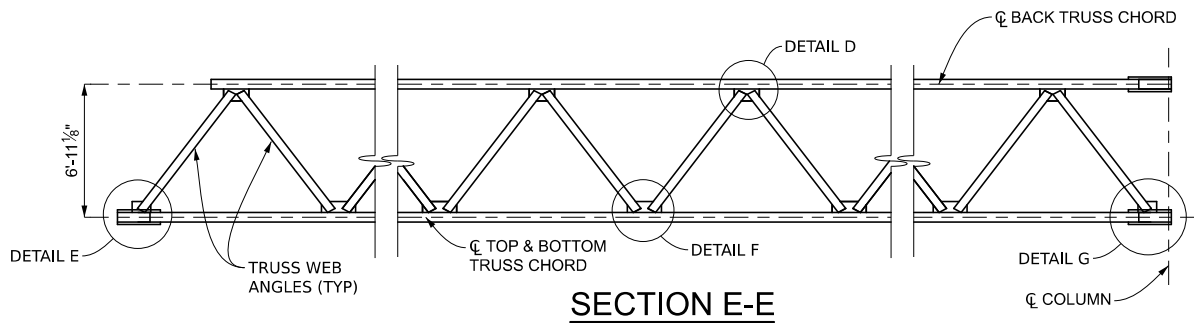

SECTION E-E

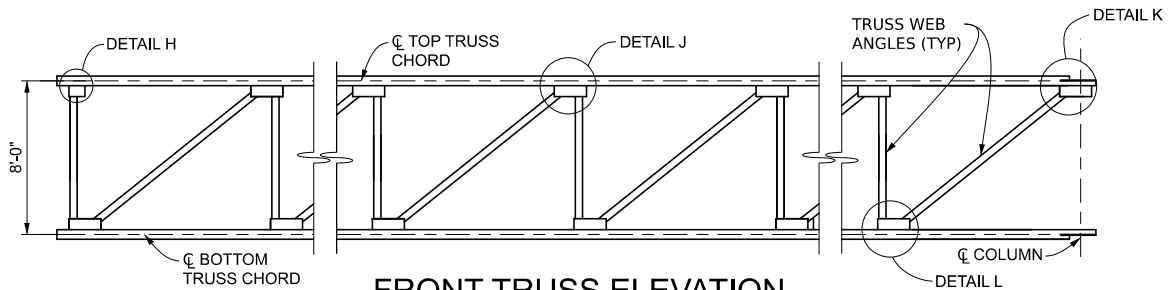

FRONT TRUSS ELEVATION

(BACK TRUSS CHORD AND ATTACHED ANGLES NOT SHOWN FOR CLARITY)



DEPARTMENT DIRECTOR
BRADLEY C. WIEFERICH, PE

STANDARD PLAN FOR
STEEL TRUSS TYPE J
(20FT - 40FT)

(SPECIAL DETAIL)
FHWA APPROVAL

08/08/23
PLAN DATE

SIGN 370-C

SHEET
7 OF 10

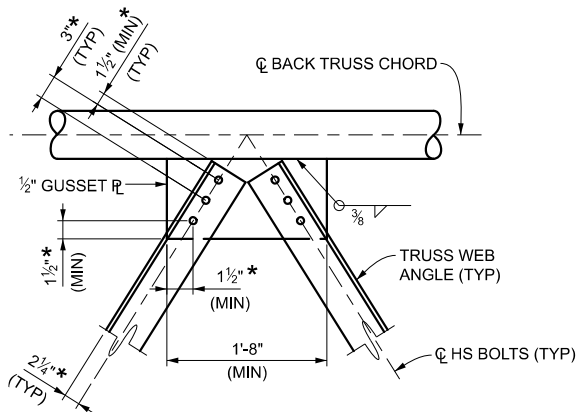

DETAIL D

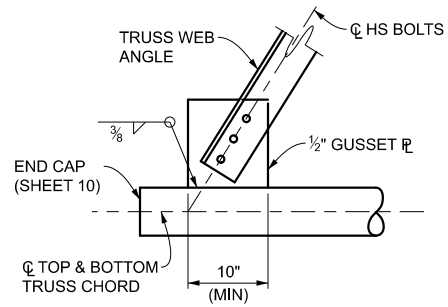

DETAIL E

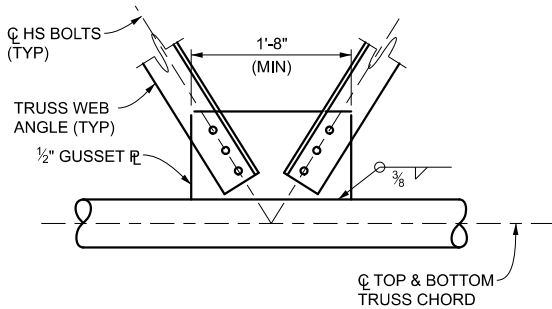

DETAIL F

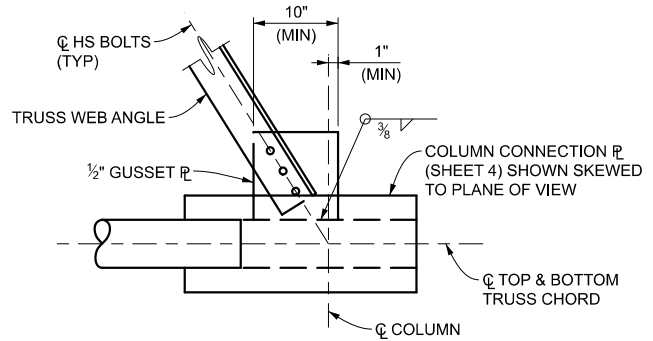

DETAIL G

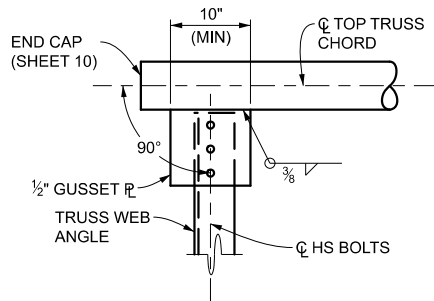

DETAIL H

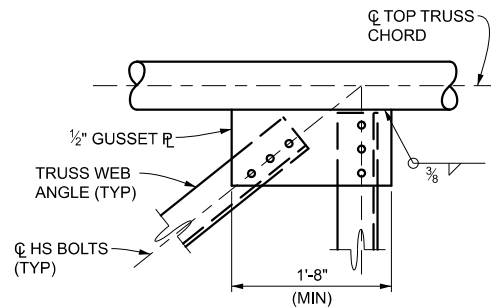

DETAIL J

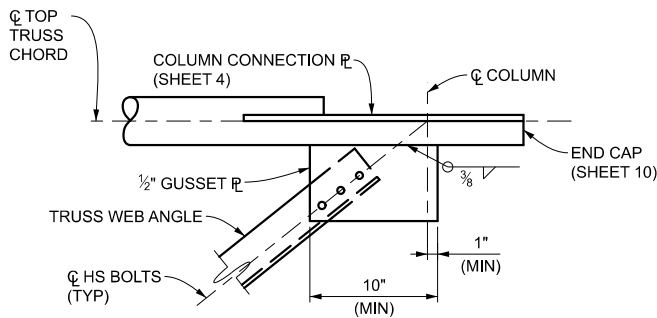

DETAIL K

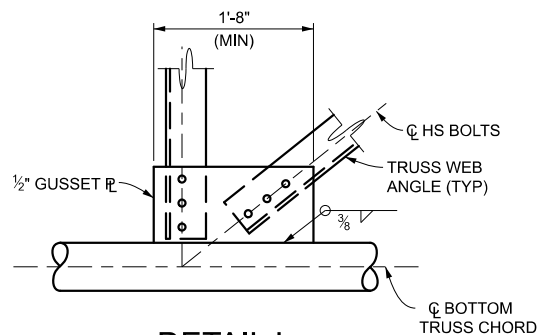

DETAIL L

SEE SHEET 9 FOR ALTERNATE CONNECTION DETAILS.
 *DIMENSION TYPICAL FOR ALL CONNECTION DETAILS.



DEPARTMENT DIRECTOR
 BRADLEY C. WIEFERICH, PE

STANDARD PLAN FOR
 STEEL TRUSS TYPE J
 (20FT - 40FT)

(SPECIAL DETAIL)
 FHWA APPROVAL

08/08/23
 PLAN DATE

SIGN 370-C

SHEET
 8 OF 10

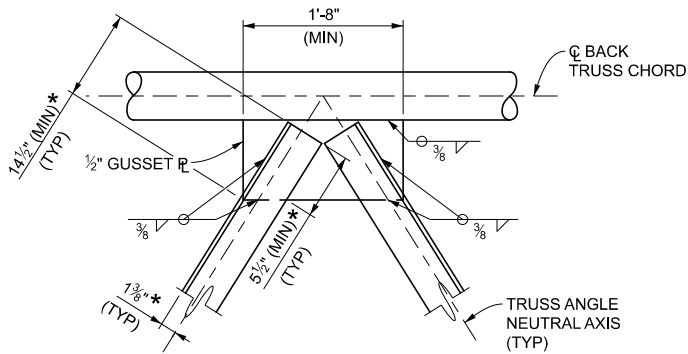

ALTERNATE DETAIL D

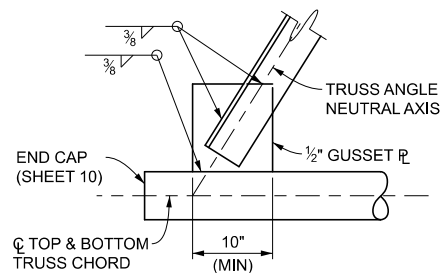

ALTERNATE DETAIL E

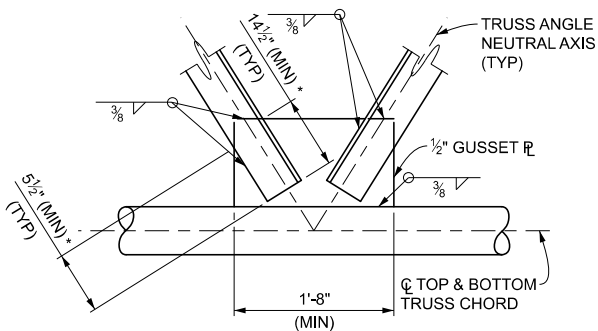

ALTERNATE DETAIL F

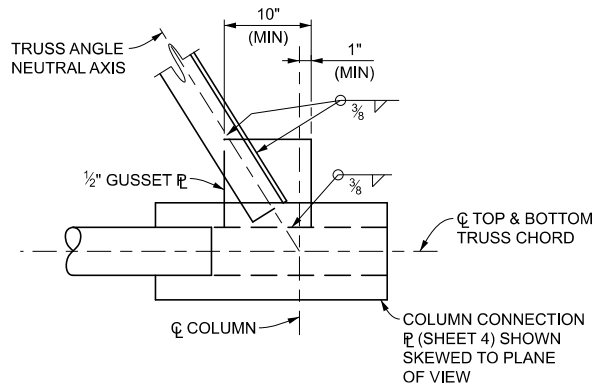

ALTERNATE DETAIL G

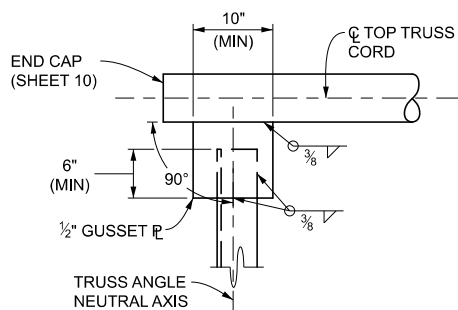

ALTERNATE DETAIL H

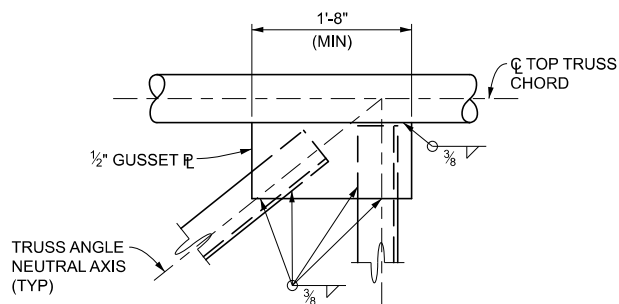

ALTERNATE DETAIL J

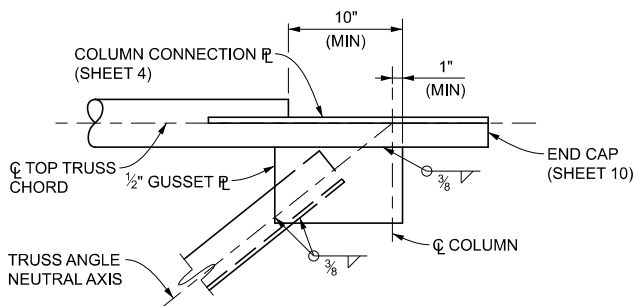

ALTERNATE DETAIL K

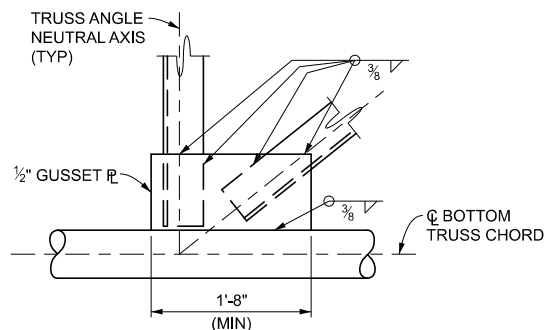

ALTERNATE DETAIL L

*DIMENSION TYPICAL FOR ALL CONNECTION DETAILS.



DEPARTMENT DIRECTOR
BRADLEY C. WIEFERICH, PE

STANDARD PLAN FOR
STEEL TRUSS TYPE J
(20FT - 40FT)

(SPECIAL DETAIL)
FHWA APPROVAL

08/08/23
PLAN DATE

SIGN 370-C

SHEET
9 OF 10

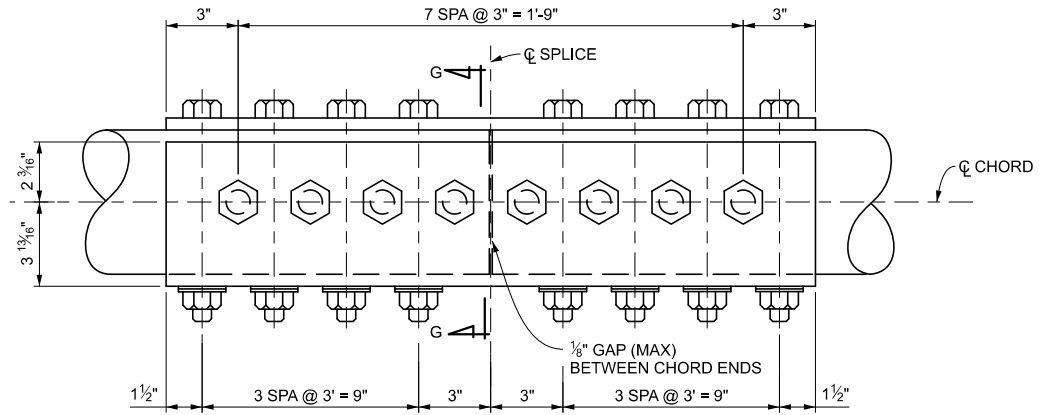

ELEVATION

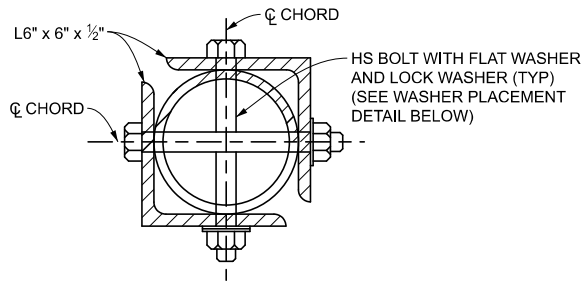

SECTION G-G

CHORD SPLICE CONNECTION DETAILS

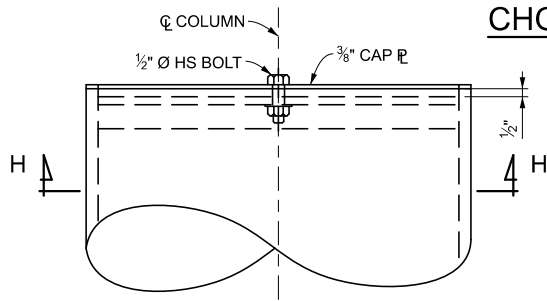

COLUMN CAP DETAIL

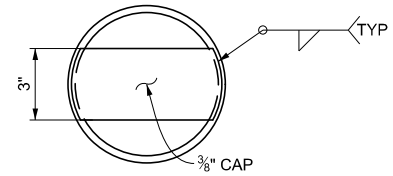

END CAP DETAIL

(USE AT EACH END OF BACK TRUSS CHORD)

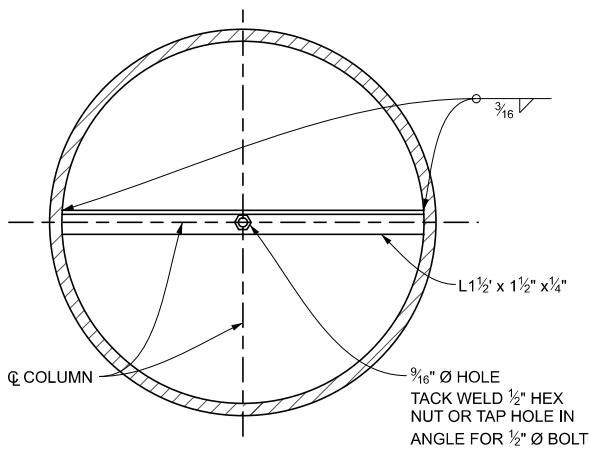

SECTION H-H

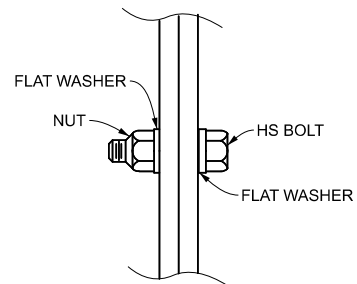

DETAIL OF WASHER PLACEMENT



DEPARTMENT DIRECTOR
BRADLEY C. WIEFERICH, PE

STANDARD PLAN FOR
STEEL TRUSS TYPE J
(20FT - 40FT)

(SPECIAL DETAIL)
FHWA APPROVAL

08/08/23
PLAN DATE

SIGN 370-C

SHEET
10 OF 10