



|  |   |                                   |                         |           |
|--|---|-----------------------------------|-------------------------|-----------|
| APPROVED BY: _____<br>DIRECTOR, BUREAU OF FIELD SERVICES | <br>Michigan Department of Transportation<br>DEPARTMENT DIRECTOR<br>BRADLEY C. WIEFERICH, PE | STANDARD PLAN FOR TRAFFIC LOOPS   |                         |           |
| APPROVED BY: _____<br>DIRECTOR, BUREAU OF DEVELOPMENT    |   | (SPECIAL DETAIL)<br>FHWA APPROVAL | 02/25/2024<br>PLAN DATE | SIG-410-A |

|   |                                   |                         |           |
|---|-----------------------------------|-------------------------|-----------|
| <br>Michigan Department of Transportation<br>DEPARTMENT DIRECTOR<br>BRADLEY C. WIEFERICH, PE | STANDARD PLAN FOR TRAFFIC LOOPS   |                         |           |
|   | (SPECIAL DETAIL)<br>FHWA APPROVAL | 02/25/2024<br>PLAN DATE | SIG-410-A |

SECT

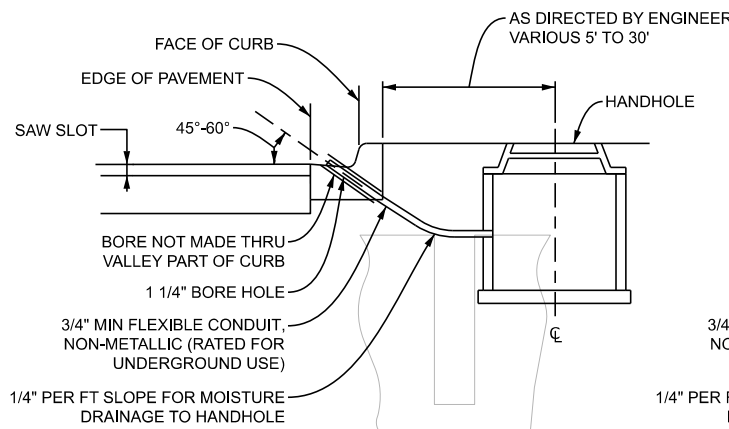

**F** TYPE I SECTION E-E  
DETAIL - UNDER CURB INSTALLATION  
N.T.S.

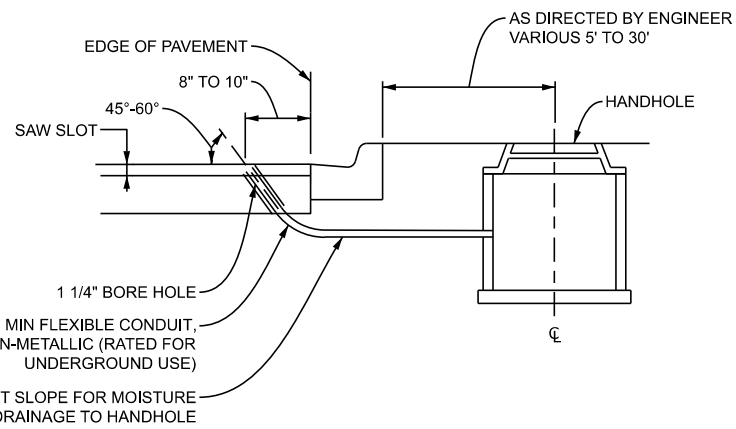

**G** TYPE II SECTION E-E  
DETAIL - UNDER CURB INSTALLATION  
N.T.S.

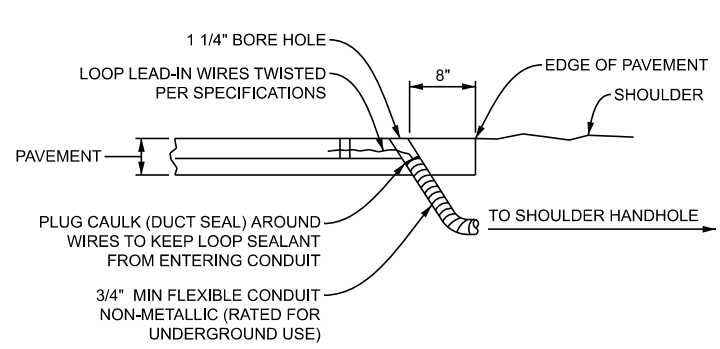

**H** BORE HOLE & LOOP WIRING  
SECTION F-F  
DETAIL - UNDER PAVEMENT INSTALLATION  
N.T.S.

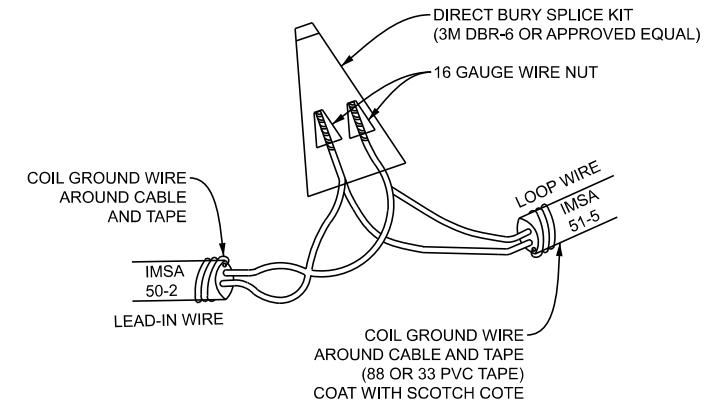

**I** DETAIL - HANDHOLE & PULL-BOX SPLICES (WATERPROOF)  
N.T.S.

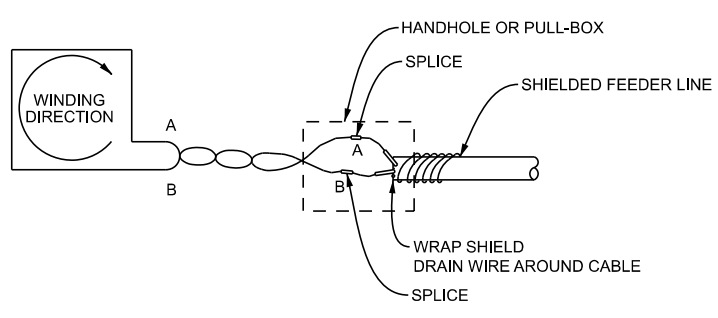

**J** DETAIL - SINGLE LOOP CONNECTION  
N.T.S.

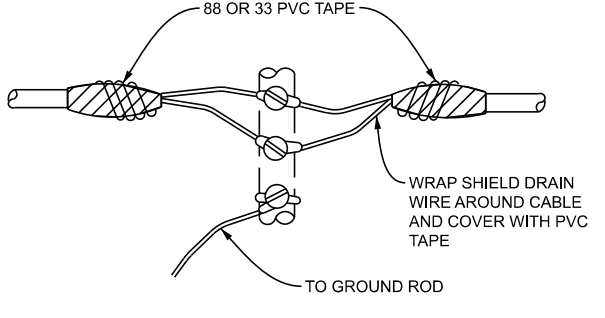

**K** DETAIL - CONTROLLER CABINET CONNECTION  
N.T.S.

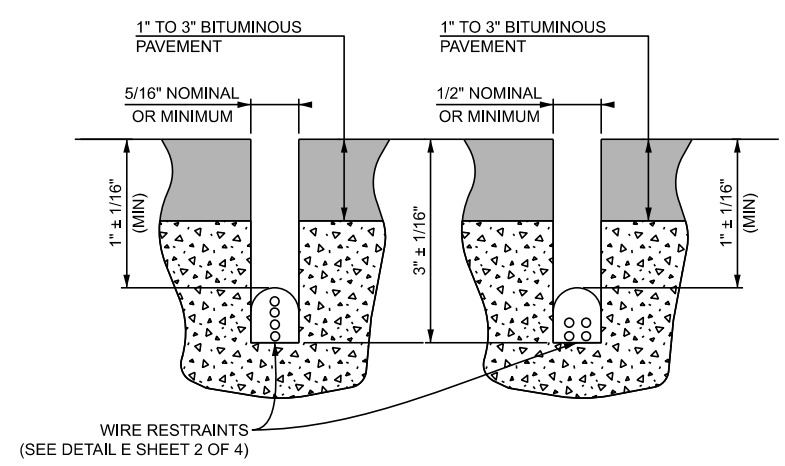

**L** SECTION A-A SECTION B-B  
LOOP SLOT LEAD-IN SLOT  
(BITUMINOUS PAVEMENT OVER CONCRETE)

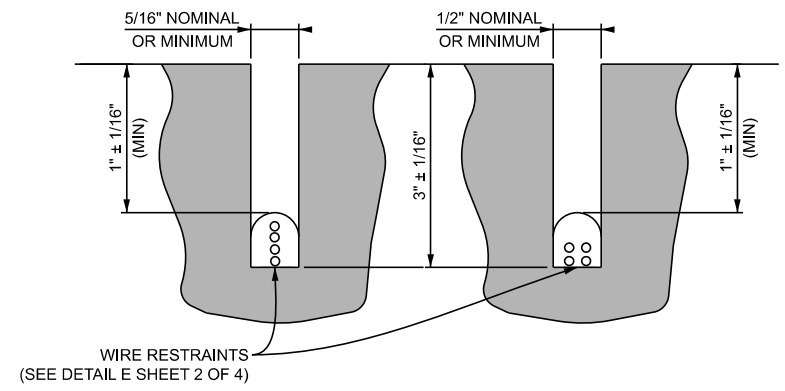

**L** SECTION A-A SECTION B-B  
LOOP SLOT LEAD-IN SLOT  
(BITUMINOUS PAVEMENT)

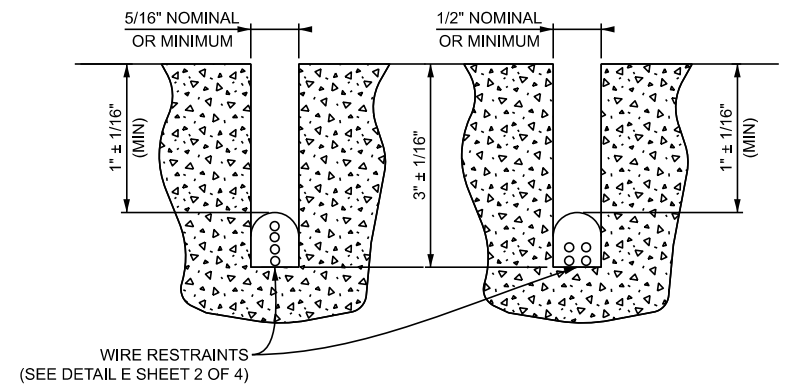

**L** SECTION A-A SECTION B-B  
LOOP SLOT LEAD-IN SLOT  
(CONCRETE PAVEMENT)

**L** DETAIL - SLOT CROSS SECTIONS  
N.T.S.

APPROVED BY: \_\_\_\_\_  
DIRECTOR, BUREAU OF FIELD SERVICES

APPROVED BY: \_\_\_\_\_  
DIRECTOR, BUREAU OF DEVELOPMENT

**MDOT**  
Michigan Department of Transportation

DEPARTMENT DIRECTOR  
BRADLEY C. WIEFERICH, PE

STANDARD PLAN FOR  
TRAFFIC  
LOOPS

|                                   |                         |                  |                 |
|-----------------------------------|-------------------------|------------------|-----------------|
| (SPECIAL DETAIL)<br>FHWA APPROVAL | 02/25/2024<br>PLAN DATE | <b>SIG-410-A</b> | SHEET<br>3 OF 4 |
|-----------------------------------|-------------------------|------------------|-----------------|

**MDOT**  
Michigan Department of Transportation

DEPARTMENT DIRECTOR  
BRADLEY C. WIEFERICH, PE

STANDARD PLAN FOR  
TRAFFIC  
LOOPS

|                                   |                         |                  |                 |
|-----------------------------------|-------------------------|------------------|-----------------|
| (SPECIAL DETAIL)<br>FHWA APPROVAL | 02/25/2024<br>PLAN DATE | <b>SIG-410-A</b> | SHEET<br>4 OF 4 |
|-----------------------------------|-------------------------|------------------|-----------------|