

HE
5627
Z6.H39
E78,
1980

UM-HSRI-80-73-1

**FUTURE CONFIGURATION
OF TANK VEHICLES
HAULING FLAMMABLE LIQUIDS
IN MICHIGAN**

**R. D. Ervin
C. Mallikarjunarao
T. D. Gillespie**

**FINAL TECHNICAL REPORT
DECEMBER 1980**



**THE UNIVERSITY OF MICHIGAN
HIGHWAY SAFETY RESEARCH INSTITUTE**

1. Report No. UM-HSRI-80-73-1		2. Government Accession No.		3. Recipient's Catalog No.	
4. Title and Subtitle FUTURE CONFIGURATION OF TANK VEHICLES HAULING FLAMMABLE LIQUIDS IN MICHIGAN Vol. I - Technical Report				5. Report Date 12/80	
				6. Performing Organization Code 384237	
7. Author(s) R. D. Ervin, C. Mallikarjunarao, T. D. Gillespie				8. Performing Organization Report No. UM-HSRI-80-73	
9. Performing Organization Name and Address Highway Safety Research Institute The University of Michigan Huron Parkway & Baxter Rd. Ann Arbor, Michigan 48109				10. Work Unit No.	
				11. Contract or Grant No. Agree. #78-2230	
12. Sponsoring Agency Name and Address State of Michigan Dept. of State Highways & Transportation State Highways Building P.O. Box 30050 Lansing, Michigan 48909				13. Type of Report and Period Covered Final 3/6/79-11/1/80	
				14. Sponsoring Agency Code	
15. Supplementary Notes					
16. Abstract <p>The special safety hazard posed by highway tank vehicles hauling flammable liquids has been addressed through accident data analysis and engineering evaluations related to tank vehicle configuration. The study, which was mandated directly by an Act of the Michigan State Legislature, has produced a recommendation for new legislation pertaining to the configuration of tank vehicles having fluid capacities in excess of 9,000 gal. A set of four vehicle configurations are recommended, all constituting tractor-semitrailers. The specification for each vehicle covers constraints on tank capacity, tank height above the ground, rollover stability, the use of so-called "lift-axles," and the ability of manhole covers to contain the fluid load in the event of a rollover.</p> <p>Analysis of accident risks has indicated that any of the four recommended vehicle configurations would yield approximately one-half of the incidence of rollover, with its potential for fire, that Michigan can expect from the use of conventional tankers having tank capacities around 9,000 gal. Further, the recommended vehicles, because of their higher carrying capacities, offer large advantages to the economy and energy efficiency of flammable fluids transportation.</p>					
17. Key Words tanker, flammable liquids, rollover, fire, traffic safety, vehicle dynamics, accidents			18. Distribution Statement UNLIMITED		
19. Security Classif. (of this report) NONE		20. Security Classif. (of this page) NONE		21. No. of Pages	22. Price

The opinions, findings, and conclusions expressed in this publication are those of the authors and not necessarily those of the Michigan State Transportation Commission.

ACKNOWLEDGEMENTS

The study reported herein involved the direct task efforts of a number of HSRI staff as well as many parties in both industry and government. We wish to acknowledge, especially, the project coordination provided by Mr. Keith Bushnell of the Michigan Department of Transportation, as well as the guidance afforded by the "Flammable Liquid Vehicle Design Advisory Panel" which was convened periodically throughout the project. Initial direction on the project was also obtained through the committees of the Michigan Legislature having cognizance over commercial vehicle safety:

- Roads and Bridges Committee of the House of Representatives
and
- Transportation and Tourist Industry Committee of the Senate

A special acknowledgement is due the Fruehauf Corporation which provided:

- test vehicles for use in the rollover impact experiments
- the aid of a senior structural engineer to advise the HSRI staff on practical constraints in tank construction
- serious evaluation of a preliminary version of the recommendations which appear in this report.

The authors wish to personally thank Messrs. L. Botkin, R. Schwartz, and H. Owen of Fruehauf for their cooperation.

Conspicuous aid was also received from the following companies and industry associations:

- Amoco Corporation
- Shell Oil Company
- Hutchinson Industries
- Holland Hitch Company
- C-B Equipment Company
- Associated Petroleum Industries of Michigan
- Michigan Trucking Association
- Truck Trailer Manufacturers Association

In addition, the following individuals contributed to the project in a notable way:

Lt. Richard Schmidt, Fire Marshall Division, Michigan State Police

Messrs. Bill Wilson and Don Morrison of the Bureau of Motor Carrier Safety, U.S. Department of Transportation

Mr. Lyn Tyndall, Dynamic Science, Inc.

Mr. Jack Landstrom, A & C Carriers

Mr. Robert Johnson, 3-K Services

Mr. Eugene Kunz, consultant on tank shell integrity, drawing from the experience of tank car safety research in the railroad industry

Professor Walter Debler, consultant on fluid dynamics concerning the rollover impact problem

Mr. Doug Rideout of the Michigan Media Center who directed the film documenting the investigation of manhole cover integrity in this project

Mr. Charles Compton, HSRI, who conducted the interrogation of computerized accident files

Dr. Tom McDole, HSRI, who conducted the field survey of tank failures during the study

Messrs. Joe Boissonneault, Don Foster and the mechanical staff at HSRI who set up the tanker rollover experiments

Messrs. John and Michael Campbell, HSRI, who provided the instrumentation services for the rollover experiments

Mr. Gary Hu, HSRI, who produced the graphics for the final report

Ms. Jeannette Nafe, HSRI, who typed the final report

TABLE OF CONTENTS

1.	INTRODUCTION.	1
2.	RECOMMENDATION FOR NEW LEGISLATION.	5
	2.1 Allowable Tank Trailer Configurations.	5
	2.2 Discussion of the Proposed Legislation	7
	2.3 Recommendation for a Proposed Retrofit Rule.	20
3.	ACCIDENT DATA ANALYSIS.	23
	3.1 State Fire Marshall Data	23
	3.2 BMCS Data Findings	27
	3.3 Michigan File.	40
	3.4 Review of a Study of Gasoline Transportation Risks.	44
4.	ANALYSIS OF THE DYNAMIC BEHAVIOR OF CANDIDATE VEHICLE CONFIGURATIONS.	49
	4.1 Analysis of the Yaw and Roll Behavior of Candidate Vehicle Configurations	49
	4.2 Effect of Vehicle Design Parameter Variations on Rollover Threshold.	116
	4.3 The Influence of Sloshing Fluid Loads.	142
5.	CONTAINMENT OF THE TRANSPORTED FLUID IN AN ACCIDENT	155
	5.1 Review of Tank Failure Data.	155
	5.2 Integrity of Manhole Covers.	166
6.	RISK OF TRANSPORTING GASOLINE	205
	6.1 The Total Annual Gallon-Miles of Gasoline Transported by Truck in Michigan	207
	6.2 The Distribution of Gasoline Tanker Travel by Type of Roadway	207
	6.3 The Distribution of Overall Accident Rate by Type of Roadway.	210
	6.4 The Distribution of Accidents, by Type of Impact, for Each Type of Roadway	211
	6.5 The Incidence of Rollover Occurring as a Result of Various Types of Accidents.	213
	6.6 Final Prediction of Rollover Risks	215

TABLE OF CONTENTS (Cont.)

7.	INCREMENT IN RISK DERIVING FROM SLOSH.	223
7.1	Gasoline Loading Patterns	223
7.2	Effect on Rollover Threshold.	224
7.3	Estimated Rollover Accident Frequency	226
8.	CONSIDERATIONS RELATED TO THE TILT-TABLE REQUIREMENT.	229
8.1	The Tilt-Table Test	229
8.2	Tilt-Table Performance Requirements	232
	REFERENCES	238

1.0 INTRODUCTION

This document constitutes the final report on a research study conducted by the Highway Safety Research Institute (HSRI) of The University of Michigan on the subject of improved safety for tank vehicles transporting flammable liquids in Michigan. The study was sponsored by the State of Michigan, with contract administration being provided by the Michigan Department of Transportation through Research Agreement #78-2230.

The project reported herein was mandated in 1978 by Act 385 of the Michigan Legislature. The primary purpose of this law was to legislate a phased removal of double tankers and to limit tank volume in the future to 9,000 gallons. Act 385 also contained the following clause:

"The Highway Safety Research Institute ... shall study vehicle design and recommend to the Legislature that vehicle combination which demonstrates the highest possible safety in transporting flammable liquids, which vehicle combination after subsequent legislation may transport flammable liquids."

Thus, the project was seen as a means to establish a solid technical foundation for enacting follow-up legislation that would regulate tank vehicles carrying flammable liquids. The project was motivated, in part, by the fact that the fuel transportation industry in Michigan had suffered a severe disturbance in its operations when the large, 17,000-gallon or so double tankers began to be phased out. Based partially upon arguments concerning the safety advantages that could be accrued with large-capacity vehicles, as a result of their low accident exposure, the Legislature conceived the research study as an opportunity to "take another look" at the whole question of tank vehicle configuration and its influence on safety.

In the absence of any follow-up legislation being enacted before November 1981, the State would become exclusively served by gasoline tankers having conventional construction and capacities not exceeding

9,000 gallons. Accordingly, HSRI's approach to the research study was to identify tank vehicle configurations that would reduce the risks of accidents, to the maximum degree, below the level that would accrue with such conventional vehicles. Although the research problem was addressed, for simplicity's sake, only from the viewpoint of gasoline as the transported product, the results were to apply also to the transportation of other hazardous liquids in vehicles meeting Federal Specification #MC-306.* Regarding vehicle configuration, conventional tractor-semitrailer tankers having either two- or three-axle trailers serve as a point of reference in this study and are referred to in the body of this report as "conventional MC-306" tankers.

The research conducted here has concluded that it is possible to significantly improve the safety of transporting gasoline by means of the adoption of a new, but practicable, set of requirements for tank vehicles exceeding 9,000 gallons in capacity. In Section 2.0 of this report, a Legislative recommendation is presented, outlining the vehicle design and performance features which should be attained to achieve the cited safety improvements. The Legislative Recommendation, of course, constitutes the Institute's direct response to the mandate of Michigan Act 385 of 1978, mentioned earlier. The recommendation is followed by a summary of the rationale supporting the details of the statement.

Whereas the recommended vehicle configurations are predicted to yield a much improved level of safety, they also appear to provide:

- 1) a net economic advantage due to the significantly reduced costs of transporting fluid products in a larger capacity tank, and
- 2) a large improvement in the energy efficiency of the transportation process itself.

*Specification MC-306 appears in the Code of Federal Regulations, Article CF 49-178.341 and entails a number of requirements for cargo tanks carrying unpressurized, hazardous liquids in commerce.

Given the timeliness of the latter two features in a climate of concern for responsible public policy on economic and energy matters, the proposed legislation, as recommended herein, is believed to be compatible with the broad interests of the State.

Further, although the recommended vehicles are configured to meet Michigan's road-use laws, it is expected that much of the technical material contained herein would also be pertinent to the improvement of tank vehicle safety in other states and countries. The study is based primarily upon engineering and accident risk analyses. Full-scale experiments and a limited amount of field survey work were also conducted to clarify certain questions regarding tank structural integrity. The methods and results pertaining to the major research tasks are contained in four sections of the report, namely:

- 3.0 Accident Data Analysis
- 4.0 Analysis of the Dynamic Behavior of Tank Vehicles
- 5.0 Containment of the Transported Fluid in an Accident
- 6.0 Prediction of Accident Risks

Two additional technical discussions, Sections 7.0 and 8.0, treat, respectively, the additional risks that can be expected if the fluid is permitted to slosh inside the transport tank and the considerations pertaining to the so-called "tilt-table requirement" by which the roll stability of the recommended tankers is specified.

Appendices A through F are also included to provide (1) technical details and data in support of accident data analysis and computerized simulations and (2) a generalized understanding of the physics of vehicle rollover.

Although the report itself is intended to document the technical study which underlies the legislative recommendation, the very "applied" quality of the results of this research has required that a good deal of engineering judgment be exercised as well. Thus the very simple scope of the recommendation derives from a judgmental distillation of the technical work. The judgments have also been guided by numerous practical considerations relating to vehicle manufacturing, the flammable

fluids transportation system, the existing accident record, and the ability of the State Government in Michigan to implement regulations of the type needed in this particular circumstance.

Moreover, the legislative recommendation represents a scientifically based statement that has been tempered through research staff interaction with the respective communities which will be regulated, as well as those who will regulate.

2.0 RECOMMENDATION FOR NEW LEGISLATION

On the basis of the study reported herein, the Institute recommends that legislation be enacted to permit the operation of tankers carrying unpressurized flammable liquids at tank capacities above 9,000 gallons, provided these vehicles meet the specifications presented in Section 2.1, below. It is also recommended that the Legislature consider a requirement that existing tankers be modified to assure that manhole covers achieve the levels of strength specified in the "recommended retrofit" statement in Section 2.3.





Both recommendations were submitted, in draft form, to a broad array of organizations involved in vehicle manufacturing, petroleum marketing, and bulk-commodity transportation for comment. To the degree that it is practicable, the following recommendations give due consideration to certain special problems that were raised by the respondents, while still assuring that the "highest possible safety" performance of the vehicles cited in the specification is achieved.

2.1 Allowable Tank Trailer Configurations

It is recommended that tractor-semitrailer configurations having tank capacities exceeding 9,000 gallons be permitted to transport unpressurized, flammable liquids in the State of Michigan, provided that such vehicles meet the following requirements.

1. Tank capacity must correspond to the "Design Volume" (+ 200 gal.) specified in Table 2.1 for each of the permitted axle arrangements. The Design Volume represents the full load fluid capacity of the vehicle. Where double bulkheads are needed, the "Design Volume" may be reduced by an amount equal to the void space(s) enclosed by the back-to-back bulkheads. The actual volume of the tank shell must exceed the Design Volume by at least 5 percent, thus providing an "outage" or expansion volume.

Table 2.1. Specifications for Advanced Michigan Tankers.

SCHEMATIC DIAGRAM OF SEMI TRAILERS	DESIGN VOLUME (gallons)	DESIGN SHELL HGT. (in.)	TILT TABLE ROLLOVER ANGLE (deg)
	10 200	111	21.5
	11 700	118	21.0
	12 400	121	20.5
	13 200	125	20.5

2. The maximum height of the tank shell must not exceed the "Design Shell Height" listed in Table 2.1 when the vehicle is fully loaded, with the trailer's fifth wheel coupler plate placed at a height of 50 inches.
3. When subjected to a tilt-table test, the tractor-semi-trailer combination must achieve a "Tilt-Table Rollover Angle" equal to or in excess of the value specified for that specific configuration (see Table 2.1).
4. No more than one trailer axle may be outfitted with a "lift-axle" type suspension. The remaining axles must act to continuously support the trailer and its load.
5. Devices used to cover manholes or inspection ports must be capable of withstanding the forces caused by an internal pressure of 50 psi, applied and held at least 50 milliseconds, and then released to 2 psi, without having any residual venting of fluid during the subsequent 2 psi condition.

2.2 Discussion of the Proposed Legislation

2.2.1 Vehicle Design Considerations. The proposed legislation contains the following features influencing vehicle design:

1. Only tractor-semitrailer configurations are included. Although many vehicle combinations (e.g., double trailers) were considered in the study, a tractor-semitrailer appears to offer the greatest level of safety since (a) its stability is inherently good and (b) it is a much simpler configuration to specify and thus much more likely to yield the minimum desired performance despite future design innovation. (We should note that certain "B-train" doubles, comprising a tractor-semi-semi configuration, offer high levels of safety quality when built in combination lengths of 65 feet and longer. However, the need for a close specification of hitching mechanisms seems to make such a vehicle impractical for regulation and enforcement by a jurisdiction with limited resources such as the State of Michigan.)

2. The proposed legislation permits four different semitrailer configurations ranging in tank capacity from 10,200 gallons to 13,200 gallons. Alternative tank capacities are proposed so as to permit latitude in transport operations. The alternative units all offer profound improvements in safety performance over conventional equipment, with the larger vehicles offering the highest safety levels while also providing the greatest economies in energy consumption and overall transport costs.

Further, the recommendation cites 9,000 gallons as the "dividing line" above which the new legislation would apply, thereby avoiding conflict with the variety of tank vehicles below 9,000 gallons which are used in interstate commerce. Since the great bulk of flammable fuels transportation in Michigan involves intrastate trucking operations, however, it is expected that the economic incentives afforded by larger capacity vehicles will lead to their popular usage within the State.

3. For each semi trailer configuration permitted, axle sets are located according to current Michigan road-use laws. In the fully loaded condition, the tractor steering axle carries 14,000 lbs, the tractor drive axle tandem carries 32,000 lbs and each close-spaced trailer axle is loaded to 13,000 lbs. In the case of the 12,400-gallon tanker, a single "spread" axle is also employed, carrying 18,000 lbs.

4. For each configuration, constraints are placed on the fluid-carrying capacity of the tank and on the maximum height of the tank shell (excluding the protective rails on the top of the tank). The tank volume constraint provides that the highest reasonable fluid volume is carried, removing the motive for reducing trailer weight to increase payload. The tank shell height constraint assures efficient "packaging" so as to minimize the height of the center of gravity and thereby maximize rollover stability. The tank capacity and shell height constraints can be achieved, in practice, by means of a design in which the tank incorporates a "drop" (i.e., deeper cross section) aft of the fifth wheel coupler area, as shown in Figure 2.1.

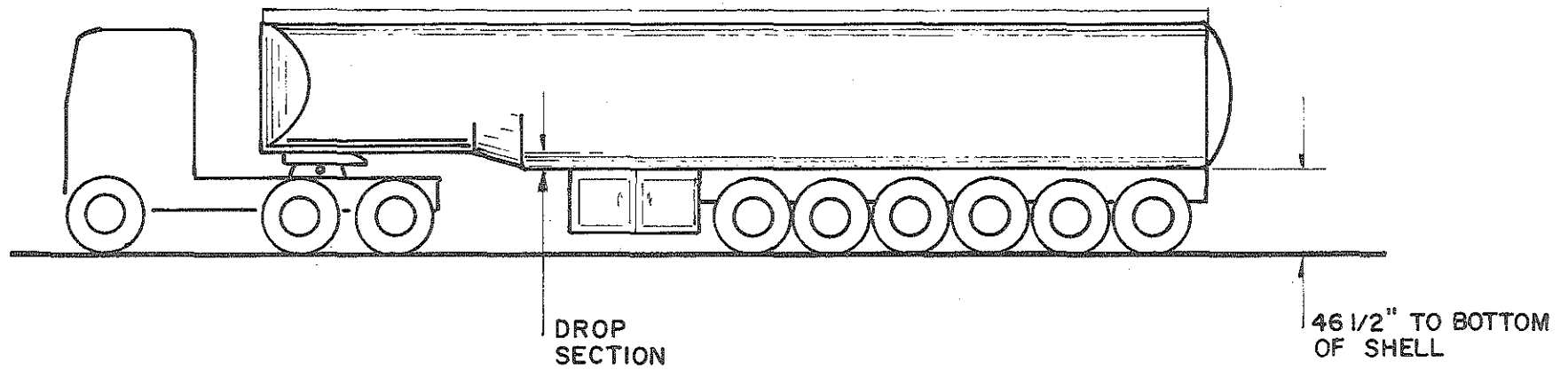

Figure 2.1. Side view of the largest Advanced Michigan Tanker, showing example drop section and the rear shell dimension that is common to all four configurations.

5. The overall rollover stability of the unit is established by a tilt-table performance test. As shown in Figure 2.2, the tilt-table test involves the mounting of a fully loaded vehicle on a plane surface which is slowly inclined until the vehicle becomes unstable in roll. (The vehicle is tethered to prevent actual rollover.) The angle corresponding to a static rollover condition is defined as the tilt-table performance measure. The static rollover condition is reached when, with no further increase in table angle, the vehicle continues to increase its roll angle unless restrained by a tether.

To meet the indicated requirements, suspension stiffnesses, spring lash, and tire stiffnesses must be within design bounds representing good practice.* If an air-lift axle is employed, the test is conducted with that axle down. The specification permits only one lift axle so as to minimize the roll-destabilizing effect that prevails when such axles are "lifted" off the roadway.

It is proposed that the State build and operate a tilt-table device for use in compliance testing, although it is conceivable that a tilt-table facility could become available for this purpose through other means. The tilt-table approach has been selected over the alternative of specifying the desired set of suspension and tire characteristics—an approach that would severely constrain design options and which would be very difficult to enforce. The proposed tilt-table test is discussed more fully in Section 8.

*One example of a vehicle design which would provide the specified level of tilt-table performance includes the following suspension features:

- The tires on each trailer axle are mounted so that the overall outside width (measured across the tires) is 101-1/2 inches.
- The lateral spread between the centerlines of the springs on leaf-spring-suspended trailer axles is 44 inches.
- The leaf spring assemblies exhibit 1/2-inch of free play, or clearance, in their vertical travel from compression to tension.

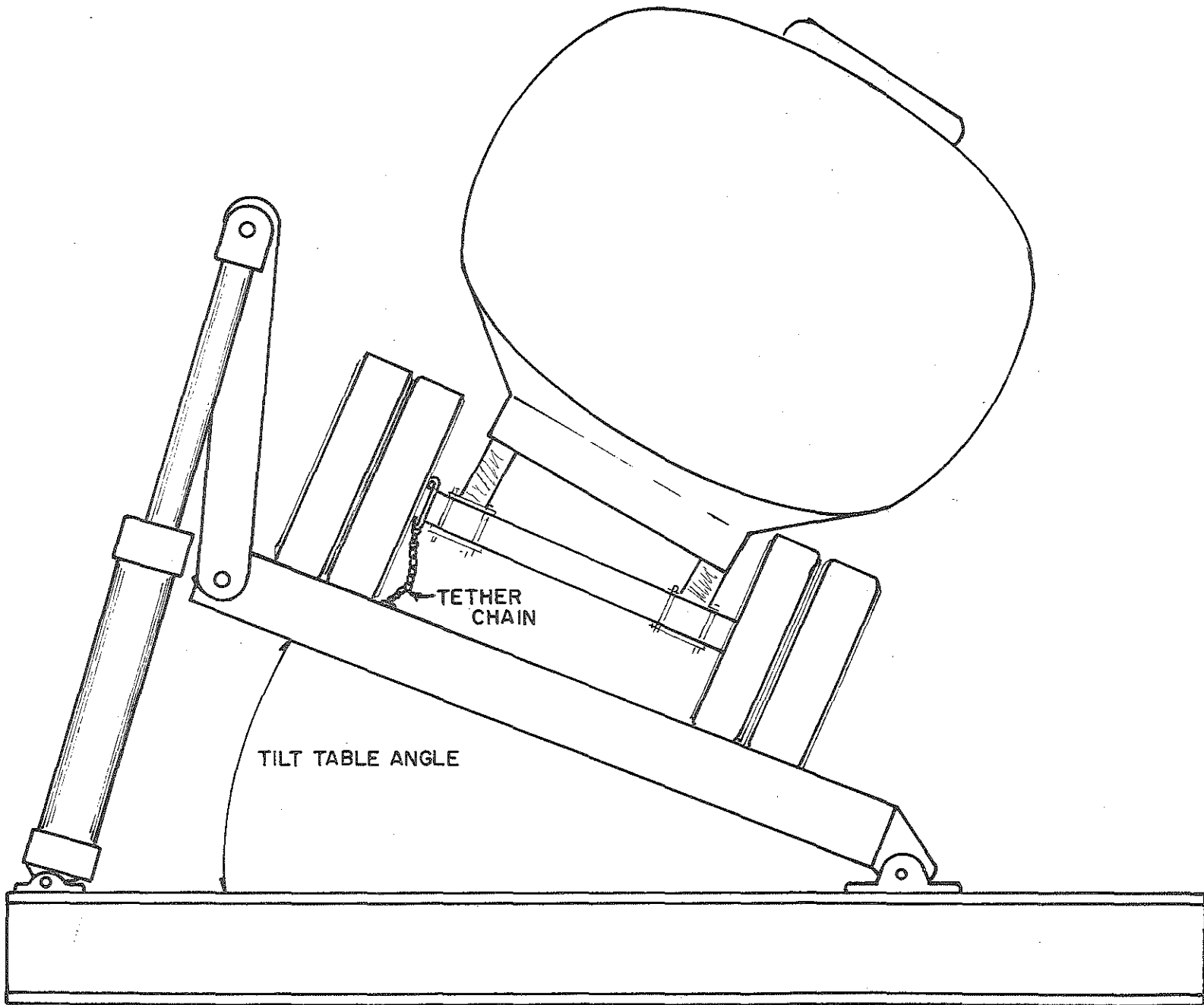

Figure 2.2 Tilt-table test concept upon which roll stability specification is based.

6. Although not explicitly required, trailers able to meet the tilt-table specification while otherwise employing conventional hardware, will be 102 inches in nominal width. That is, under special provision for tankers carrying flammable liquids, the maximum width of the tank and the spread across the outside of the trailer tires will be permitted to be 102 inches rather than the conventional dimension of 96 inches.

It is appreciated that allowing a 102-inch width dimension for tank vehicles constitutes a significant change from the status quo, and that a 102-inch width is authorized in the State currently only under special permit. Nevertheless, the recommendation is made with the firm conviction that, for heavy tankers carrying hazardous liquids, improvement in roll stability is the key safety issue. The proposed 102-inch width accounts for the major portion of the increase achieved in roll stability and is second only to tank capacity as a vehicle feature helping to achieve the reduced level of risk afforded by the recommended vehicles. (In section 2.2.2, the reduction in rollover risks to be expected with 102-inch wide tankers is examined in comparison to conventional 96-inch wide tankers.)

There is also a considerable body of evidence to show that the 102-inch width dimension introduces no peculiar safety problems of its own. Extensive study of the question in behalf of the current federal allowance of 102-inch wide buses on the interstate system showed no significant hazards associated with the greater width [1]. It should be noted that all of the provinces of Canada allow 102-inch wide commercial vehicles to operate, although Canadian roads are built to geometric standards that are not essentially different from those in Michigan.

-
- Trailer leaf springs exhibit a stiffness level which averages 10,000 lb/in per spring over the normal compression range and 4,000 lb/in after traveling through the free play into the tension range.
 - A typical line-haul tractor, 96 inches in width, is used for which the spring rates on the tractor tandem axles average 6,000 lb/in per spring over the normal compression range and 4,000 lb/in after traveling through the free play into the tension range.
 - The leading trailer axle incorporates an air suspension which provides a roll stiffness level of 118,000 in-lb/deg.

7. The recommendation contains no statement regarding tank shell material, although the higher abrasion resistance and the ability to withstand the temperatures of a gasoline fire argue strongly for a steel tank shell over the other likely alternative, aluminum. The draft recommendation submitted to outside parties for review did specify steel as the shell material, but an industry respondent providing feedback on the recommendation pointed out that certain transported fluids having a low flash point must be delivered in aluminum (or presumably stainless steel) vessels for the sake of minimizing the contamination of the liquid.

Further study of the subject of shell material revealed that the great majority of prospective purchasers of "Advanced Michigan Tankers" would have no economic incentive for choosing the more expensive aluminum construction and thus would naturally opt for steel shells just as has been the case for the majority of the larger tank trailers which have been used to transport flammable liquids in Michigan in the past. Thus, it was concluded that a requirement for steel as the tank shell material would only serve to hamper certain areas of commerce while otherwise achieving little additional safety benefit than would occur normally due to the inherent economic incentive to employ steel.

8. A requirement is placed upon the pressure retention capacity of manhole covers and inspection ports so that these devices will withstand the pressure pulse that is produced in a rollover impact. The primary purpose of this requirement is to prevent the wholesale failure and dislodging of manhole covers in rollover accidents. Secondly, the requirement assures that the momentary relief action of venting devices installed on such covers will not be followed by a sustained leaking of the assembly when the pressure is reduced below the 3 psi vent setting. Field survey data and full-scale experiments supporting the manhole cover specification are presented in Section 5.

9. Regarding the economic significance of the recommendation, it is expected that the larger capacity vehicles will be highly attractive for minimizing transport costs. A first-order estimate of the economic advantage afforded by the larger tank volumes has been made

with the aid of information obtained from one of Michigan's larger for-hire carriers of petroleum products. Given an estimated .15 cents per gallon reduction in transportation costs for a 13,200-gallon tank volume, as opposed to a 9,000-gallon tank volume, the larger vehicle would yield a net reduction in costs to its operator of approximately \$15,000 per year. This figure is based upon the following specifications:

- 0.15 cents per gallon cost reduction in transportation costs
- 13,200 gallons transported per trip
- 3.6 trips per day [2]
- 210 days of operation per year

A major tank vehicle manufacturer has estimated that the new purchase price of the recommended six-axle, 13,200-gallon trailer will be approximately \$30,000 more than the price of conventional 9,000-gallon tankers that are manufactured in large numbers. Accordingly, the larger vehicle would pay for itself in a rather short time in comparison with the expected 15- to 20-year life of the trailer.

10. Regarding the energy efficiency of flammable liquids transportation, it is estimated that the approximate ten million gallons of diesel fuel which are consumed in transporting 5.1 billion gallons of gasoline in Michigan each year would be reduced markedly by adoption of a fleet of tankers having the larger recommended capacities in comparison to a fleet of 9,000-gallon tankers. The fuel consumption of a tractor pulling a 13,200-gallon tanker, expressed in gallons of diesel fuel consumed per gallon of product delivered, is expected to be at least 20 percent less than the consumption of a suitably sized tractor pulling a 9,000-gallon tanker.

2.2.2 Safety Considerations. The safety analysis leading to the proposed recommendation can be summarized as follows:

a) The special concern for the safety of tankers transporting flammable fuels derives from the fire threat.

b) Since rollover is clearly the dominant means by which fires are produced, an improvement in those vehicle features which influence rollover resistance is central to minimizing the fire threat.

c) The accident data analyzed in this study show that the rollover of heavy tractor-semitrailers is:

- 1) overwhelmingly a single-vehicle accident event—that is, the combination vehicle rolls over without having impacted any other vehicle, and
- 2) the incidence of such rollovers is profoundly influenced by the inherent roll stability of the vehicle. Shown in Figure 2.3 is a plot of the percent of single-vehicle accidents in which tractor-semitrailers roll over versus the rollover threshold of each vehicle. It has been predicted that the recommended tanker configurations would experience from 64 to 72 percent of the rollover frequency (i.e., rollovers per accident) of the conventional MC-306 tanker used in most other states to carry gasoline.

d) Since the total number of rollovers in a given year will depend on the total number of accidents as well as on the likelihood of rollover given an accident, it is important that total exposure be kept low by minimizing the total vehicle miles being traveled. Vehicle miles are reduced when larger capacity tanks are employed. But with larger capacities, the tank center of gravity will be located at a greater height. The four recommended vehicles embody tank capacities and rollover thresholds which result in virtually identical estimates in the total number of rollovers in the fleet per year, as shown in Figure 2.4.* The data suggest that each of the four vehicles represents very nearly

*That is, if the entire Michigan gasoline transportation mission was served by a fleet comprised exclusively of the vehicle shown, the number of rollovers per year would be approximately as indicated.

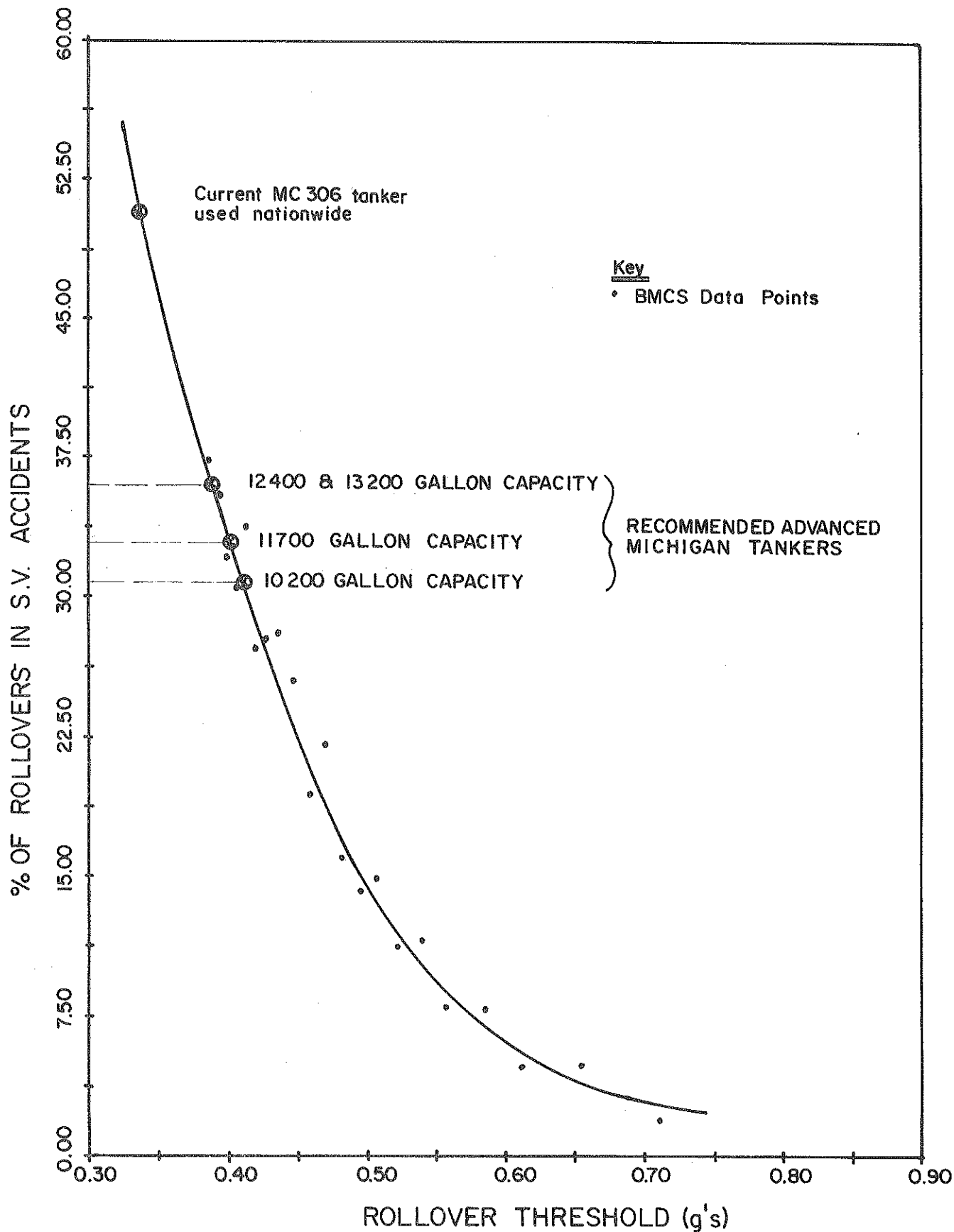

Figure 2.3. Percent of single-vehicle accidents in which rollover occurs as a function of the vehicle's inherent rollover threshold, in g's. (This figure is based upon 21,000 accident cases reported to the BMCS.)

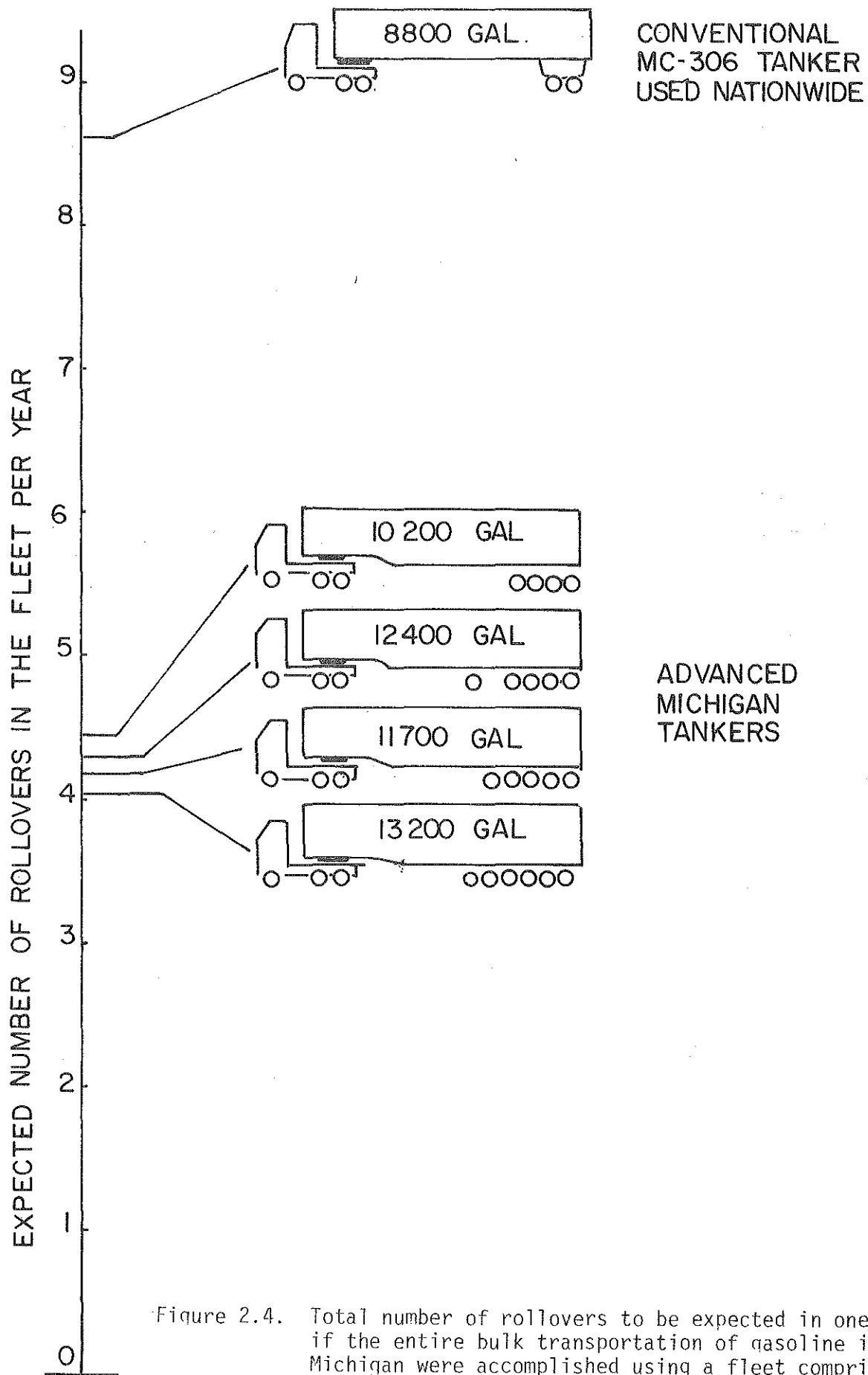

Figure 2.4. Total number of rollovers to be expected in one year if the entire bulk transportation of gasoline in Michigan were accomplished using a fleet comprised exclusively of each vehicle type shown.

the same fire threat as the other, although any one of the four would yield at least a 48 percent reduction in total rollovers per year compared to the conventional MC-306 tanker, as indicated at the top of the figure.



As mentioned previously, the 102-inch width of the recommended tankers accounts for a large portion of the reduction in rollover risk. Shown in Table 2.2 is the contrast in rollover thresholds and the annual risk of rollover applying to 96-inch and 102-inch wide versions of each of the four recommended tankers. We see that the proposed 6 percent increase in width yields, by itself, a 20 percent reduction in the incidence of rollover.

e) The total number of accidents of all kinds (i.e., not simply rollover accidents) should, of course, be directly reduced by additional tank capacity since exposure in vehicle miles is virtually the only issue. Among the recommended vehicles, for example, the 10,200-gallon tanker would be expected to yield approximately 30 percent more total accidents than would the 13,200-gallon vehicle. Thus, although the 10,200- and 13,200-gallon vehicles yield nearly identical predictions of total rollovers, the larger vehicle appears to offer a considerably higher level of overall safety due to the fewer total number of accidents of any kind.

f) The additional risk posed by the quantity of flammable liquid available for involvement in a single fire is not thought to be significant given the alternative vehicle sizes being considered. The consensus of the fire-fighting community seems to be that the threat to life posed by large gasoline fires is not dependent upon tank size, when tank capacity exceeds a few thousand gallons. As stated in the manual of the National Fire Protection Association (NFPA),

"The danger from a gasoline fire is not in direct proportion to the quantity of gasoline. One thousand gallons of gasoline released to burn in the street would be sufficient to kill everyone trapped in the flames. Four thousand gallons, while presumably covering a larger area, would certainly not be expected to cause four times the number of fatalities. Reasoning on this basis, the NFPA Standards have not recommended any limitation on the maximum size of tank trucks."

Table 2.2. Comparison of the Rollover Thresholds and Total Annual Rollover Risks Posed by "Advanced Tankers" of 96-Inch Versus 102-Inch Width.

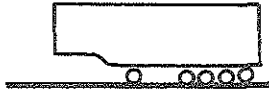
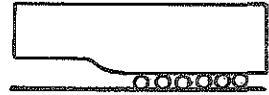
SCHEMATIC DIAGRAM OF SEMI TRAILERS	ROLLOVER THRESHOLD, g's			EXPECTED NO OF ROLLOVERS/YEAR		
	96" Wide Trailer	102" Wide Trailer	% increase in rollover threshold	96" Wide Trailer	102" Wide Trailer	% Decrease
	.38	.415	9.2%	5.58	4.45	-20%
	.369	.406	10.03%	5.29	4.18	-21%
	.357	.394	10.36%	5.40	4.30	-20.46%
	.355	.393	10.7%	5.16	4.06	-21.3%

g) The advantages which will accrue from the higher pressure containment specification for manhole covers appear to be very significant. Examination of 33 individual cases of rollover of heavy gasoline tankers in Michigan reveals that 23 vehicles suffered spillage of product, and 13 of the spills occurred due to failure of the manhole cover.

In each of four full-scale rollover tests conducted in HSRI's study, manhole covers of conventional design were blown completely off the vehicle. Upgrading such designs to withstand the specified pressure levels is expected to reduce the incidence of cover failures to simply that level deriving from improper maintenance. Analysis and experiment both reveal that the use of a non-failing manhole cover will not lead to a higher likelihood of rupture of the tank shell.

h) In summary, the recommended vehicles, if used exclusively to transport unpressurized flammable liquids in Michigan, would be expected to yield a total number of rollovers that would be approximately one-half of the rollovers which would be otherwise expected if conventional MC-306 tankers having a 9,000-gallon capacity become the common means for transporting gasoline in the State. The proposed improvements in the integrity of manhole covers should result in an even greater reduction in the number of fires.

2.3 Recommendation for a Proposed Retrofit Rule

It is proposed that a regulation be promulgated requiring the retrofitting of any tank vehicle in Michigan falling under Federal Regulation MC-306 to assure that manhole and inspection-port covers will not fail and release product in a rollover. The proposed rule should incorporate the following statement:

"Devices used to cover manholes and inspection ports must be shown to be capable of withstanding an internal pressure of at least 50 psi without impairing the product retention capability of the device."

The proposed retrofit requirement is based upon the observation that over half of the spillage of flammable product in rollover accidents in Michigan derives from manhole cover failure. HSRI's experiments (see Section 5.2) have shown that the failure which commonly

occurs is of a most simple type—namely, a clamping band fastening the cover plate to the tank becomes distorted under the internal pressure load such that the entire manhole-cover assembly comes off of the vehicle. A 16- to 20-inch diameter opening in the shell results, such that the contents of the tank compartment are released within a few minutes.

One simple retrofit could consist of installing a simple beam over the manhole cover—hinged at one end by a connection to one of the rollover-protective rails on the top of the tank, and latched at a connection attached to the other rail. The vehicle operator could simply unlatch the beam and swing it up to open the fill cover for top loading. Another simpler possibility might involve the use of a much stronger clamping band in place of the existing bands which hold the manhole cover to the tank.

3.0 ACCIDENT DATA ANALYSIS

The methods and results of the accident data analyses which have been conducted to clarify the problem of tanker accidents are presented below in order to predict the accident risks that will be posed by an advanced type of tanker configuration.

In Section 3.1, a data file compiled by the Michigan Fire Marshall's Office is reviewed with particular attention given to the incidence of rollover, fuel spillage, and fires. In Section 3.2, an analysis is presented covering data sorted from the computerized files of the Bureau of Motor Carrier Safety (BMCS) of the U.S. Department of Transportation. The BMCS file is used to determine a relationship between the involvement of tractor-semitrailers in rollover accidents and the inherent rollover limits exhibited by such vehicles. (The derived relationship is employed in Section 6.0 to predict the risk of rollover to be expected if the recommended tankers were to be placed in general service in Michigan. Rollover is of special interest, since the incidence of significant amounts of fluid spillage from tank vehicles derives almost exclusively from rollover events.) In Section 3.3, truck accident data gathered in the State of Michigan are briefly examined to establish the frequencies with which differing types of accidents occur involving tractor-semitrailers on each of various road types. (These results are employed in the prediction of tanker risks, Section 6.0, as a means of accounting for the peculiar accident exposures deriving from Michigan's traffic and Michigan's road system.) Finally, in Section 3.4, a brief review is presented of a research study which analyzed the risks posed by the transportation of gasoline in the U.S. Insofar as this study involved an examination of the tanker accident record, it is included here as a very pertinent reference.

3.1 State Fire Marshall Data

A rash of gasoline tanker accidents in 1977 prompted the Fire Marshall's Office of the Michigan Department of State Police to initiate a record of accidents and incidents involving tank vehicles hauling

hazardous cargo in Michigan. The records maintained by the Fire Marshall's Office include information on the mechanism causing spillage, the amount of spillage, cargo type, number of trailers, incidence of fire, etc. A sample accident report is shown in Figure 3.1. A total of 130 such accident reports (79 reports for 1978 and 51 for 1979) were obtained to produce the information tabulated in Appendix A.

Of the 130 tanker accidents tabulated in Appendix A, 21 involve single-bottom (tractor-semitrailer) gasoline tankers and 18 involve double-bottom gasoline tankers. Since only gasoline tanker accidents are of interest to this study, the discussion below focuses on these 39 single- and double-bottom tanker accident reports.

3.1.1 Gasoline Releases and Fires. Table 3.1 summarizes the incidence of gasoline releases and fires for the years 1978 and 1979. The table indicates that, of the 21 single-bottom accidents reported to the Fire Marshall's Office, 14 were overturns and 7 were non-overturn accidents. All of the 14 single-bottom tanker overturns resulted in the release of at least some quantity of gasoline. The amount of gasoline released in an overturn ranged from 5 to 13,000 gallons, with an average of 3,942 gallons. Of the 7 non-overturn accidents, there was only one significant release of gasoline—a 1,000-gallon release due to a tank shell rupture during a side-swipe accident.

In the case of double tankers, 13 of the reported accidents involved an overturn and 5 were non-overturn accidents. Gasoline was once again released in almost all of the overturns, ranging from 20 gallons to a total cargo loss of 17,000 gallons due to fire. The releases due to double tanker overturns averaged 5,408 gallons, which is about 1,500 gallons higher than the average for the single-bottom tankers. No gasoline was released during the 5 non-overturn accidents involving double tankers.

There were a total of 8 fires involving gasoline cargos, of which 3 involved tractor-semitrailers and 5 were connected with double tankers. All fires were as a result of an overturn accident. The data therefore indicate that 21 percent of all single-bottom tanker overturns resulted in a fire, while about 38 percent of all double-bottom tanker overturns resulted in a fire.

XFH-56 (4-78)

HAZARDOUS MATERIALS SECTION
TRANSPORTATION UNIT
ACCIDENT/INCIDENT REPORT

311-79

⑤

Accident XXX Incident _____ Other _____ Product gasoline & fuel oil
Spill xxx Leak _____ Amount 337 gal. gasoline Fire no Explosion no
Date 1-17-79 Time 10:20 am County Isabella City/Twp Rolland
St./Hwy on Blanchard Rd. 3/10 mi. east of Rolland Rd. Blanchard may have shut one lane
to upright tanker - 1 hr?
Veh. Type: D.T. _____, S.B. xxxx D.B. _____ Other _____ Weather snow covered roads

Veh. Owner _____ Address _____

Driver _____ Address _____

D.O.B. 2-23-40 Driving Exp. Truck 15 F.L. 7 Other _____

Injuries: Name None Address _____

Name _____ Address _____

Name _____ Address _____

1. Tr/Del. Year _____ Make _____ P.I.N. _____

Date Last Insp. _____ Cap _____ L _____ H _____ Load _____

2. S.T. Year 1968 70 Make Custom P.I.N. 3129010003

Date Last Insp. 10-18-78 Cap 6,000 L 39' H _____ Load 1,000 fuel oil
1,800 gasoline

3. TRL Year _____ Make _____ P.I.N. _____

Date Last Insp. _____ Cap _____ L _____ H _____ Load _____

Accident/Incident Remarks: _____

Vehicle travelling west on Blanchard. Driver steered to right to avoid parked cars
on left side of main road. Road narrowed due to snow drifts. Front tractor tire
ran off road followed by semi-trailer causing tank to overturn onto side in snow bank
Back compartment filled w/gasoline. Fuel Oil divided between 3 compartments.

CAUSE: Pressure of gasoline on dome covers caused leak past gasket. No fuel oil leak.

CAUSE: Road conditions & driver actions.

Fire Safety Violations: None contributing to cause. No on-the-scene inspection.

Hydro-static test of ~~xxxxxtxxxx~~ compartments requested.

Arrest: Name None Charge _____

Reinspected By: _____

Investigated By: D/Sgt Arthur R. Nash Jr.

JB

Figure 3.1. Sample of accident reports maintained by the Fire Marshall's Office.

Table 3.1

SUMMARY OF ACCIDENTS INVOLVING GASOLINE TANKERS IN 1978 & 1979

		FREEWAYS		HIGHWAYS		OTHER ROADS		TOTAL
		Rural	Urban	Rural	Urban	Rural	Urban	
<u>Single Bottoms</u>								
TOTAL NUMBER OF ACCIDENTS		3	5	3	3	3	4	21
Overturning Accidents	OVERTURNING ACCIDENTS	1	3	2	2	3	3	14
	RELEASE QTY. (gallons)	5	9000, 8000, 200	13000, 8000	800, 8200	100, 337, 1000	2555, 50 unknown	
	AVERAGE RELEASE	5	5733	10500	4500	479	>868	3942
	CARGO FIRES	0	1	1	1	0	0	3
Nonoverturning Accidents	NON OVERTURNING ACCIDENTS	2	2	1	1	0	1	7
	RELEASES	0, 30	0, 1000	0	0	0	0	
	AVERAGE RELEASE	15	500	0	0	0	0	
	CARGO FIRES	0	0	0	0	0	0	0
<u>Double Bottoms</u>								
TOTAL NUMBER OF ACCIDENTS		6	2	7	0	3	0	18
Overturning Accidents	OVERTURNING ACCIDENTS	5	0	6	0	2	0	13
	RELEASE QTY. (gallons)	13300, 1000, 5800, unknown, 4500		100, 20, 5500, 11600, 4000, 2050		30, 17000		
	AVERAGE RELEASE	>4920		3878		8515		5408
	CARGO FIRES	2		2		1		5
Nonoverturning Accidents	NONOVERTURNING ACCIDENTS	1	2	1	0	1	0	5
	RELEASES	0	0	0	0	0	0	0
	CARGO FIRES	0	0	0	0	0	0	0

3.1.2 Locations of Gasoline Releases and Fires. Gasoline tanker accidents in Michigan are aggregated by roadway category (viz., freeways, highways, and other roads) in Table 3.1. Based on the population of the city or township in which the accident occurred, the accidents are further classified into rural and urban accidents.

The data indicate that single-bottom tankers were involved in more overturns in urban areas than rural. Eight out of the 14 single-bottom tanker overturns were in urban areas. By contrast, none of the 13 double tanker rollovers were in urban areas. This difference in urban/rural rollover incidence distribution for these tankers can be explained by the fact that restrictions on the usage of double tankers has limited their use mainly to gasoline distribution in rural areas. The pattern of gasoline releases and fires follow those of overturns. Only 2 out of the 8 gasoline tanker fires took place in urban areas.

3.1.3 Cause of Tanker Overturns. The comments in the tanker accident reports were studied with the aim of determining the nature of the accidents which led to a tanker overturn. Table 3.2 classifies the single and double tanker overturns into single-vehicle accidents, collisions at right angles, frontal collisions in which the rear-end of a vehicle other than the tanker is impacted, head-on and side-swipe collisions. The data show that for both single and double tanker accidents, single-vehicle accidents are the major cause of overturns. Twenty-two out of the 27 rollovers (or 81 percent) occurred in single-vehicle accidents. With respect to collision events, frontal collisions are seen to cause the greatest number of overturns.

3.2 BMCS Data Findings

Rollover incidence data from the BMCS accident data file will be utilized below to establish a relationship between the rollover threshold of commercial vehicles and their rollover involvement. Such a relationship constitutes the key data resource for predicting the effects of various design changes on the rollover involvement of tank vehicles.

Table 3.2. GASOLINE TANKER OVERTURNS IN MICHIGAN

	SINGLE VEHICLE	COLLISION				TOTAL
		Collision at Right Angle	Frontal Collision	Head on	Sideswipe	
1978						
SINGLE BOTTOM	4	0	1	0	0	5
DOUBLE BOTTOM	8	0	1	0	1	10
TOTAL	12	0	2	0	1	15
1979						
SINGLE BOTTOM	7	1	1	0	0	9
DOUBLE BOTTOM	3	0	0	0	0	3
TOTAL	10	1	1	0	0	12
1978 AND 1979 COMBINED	22	1	3	0	1	27

81% of rollovers due to single vehicle accidents
 19% due to accidents involving collisions with other vehicles

3.2.1 Features of the BMCS Data File. The Bureau of Motor Carrier Safety accident file is a compilation of truck accident data reported to the Bureau by the commercial motor carriers. The BMCS data, though restricted mainly to interstate motor carrier accidents, contains about 30 to 50 percent of all major truck accidents which occur each year in the United States. An accident is considered reportable to BMCS if the accident resulted in:

- 1) a fatality,
- 2) bodily injury to a person who, as a result, received medical treatment away from the scene of the accident, or
- 3) total damage to property in excess of \$2000.

The BMCS data file is one of the few accident data files which contain a detailed description of the trucks which are involved in accidents. Information pertaining to vehicle body type, commodity carried, number of axles on tractor, number of axles on the trailer, gross vehicle weight, etc., can be easily extracted from the data file. With regard to the use of the BMCS data for the purpose of analyzing the overturn rates of trucks, the main shortcoming is that those overturns which involve a collision of the truck with another vehicle are not identifiable in the data. The overturn incidents that can be analyzed using the BMCS data are therefore restricted only to those occurring in single-vehicle accidents. Nevertheless, other data sources have been utilized to establish that, of all rollovers of heavy tractor-semitrailers, approximately 80 percent occur in single-vehicle accidents. Accordingly, analysis of rollover relationships using BMCS data can be looked upon as addressing the dominant portion of the heavy truck rollover problem.

3.2.2 Derivation of a Relationship Between Rollover Threshold and Rollover Accident Involvement. In order to utilize the BMCS data file as a source of accident data illustrating a relationship between vehicle configuration and rollover involvement, the following method was employed:

1. A vehicle type was selected whose rollover threshold could be reasonably approximated, given the gross weight.
2. The BMCS file was sorted to identify the occurrence of rollover at each nominal level of gross weight for all vehicles of the selected type.
3. A scheme was determined for locating the nominal height at which the center of gravity of the payload would be placed in simulating the rollover performance of the selected type of vehicle. Using this c.g. height, then, the rollover threshold of the selected vehicle was calculated for each level of gross vehicle weight which had been covered in the BMCS file. The data were then plotted, illustrating the relationship between the steady rollover threshold and the percentage of rollovers actually occurring in single-vehicle accidents.

Taking each of these steps in turn, the method will be presented in the following discussion.

Selected Vehicle

The selected vehicle was the three-axle tractor, two-axle van-body semitrailer configuration. This vehicle type was seen as particularly suited for a rather generalized evaluation of rollover thresholds not only because it is, by far, the single most prevalent heavy combination vehicle in the U.S., but also because there is a high degree of uniformity in design parameters among vehicles in this category. Data compiled by the Truck Trailer Manufacturers Association [3], for example, shows that of a sampling of van-type semitrailers produced in model year 1978:

100 percent were, of course, 96 inches in outside width
99 percent were between 12 feet 6 inches and 14 feet in overall height (of these, 64 percent fell within the most popular range of heights, 13 feet to 13 feet 6 inches)

91 percent were between 40 feet and 47 feet in overall length.

Additionally, it is known that the vast majority of these trailers employ four-spring type tandem suspensions for which representative spring stiffness data are available.

Because of the uniformity of design geometry, it is possible to make rather reliable estimates of certain average vehicle parameters influencing rollover threshold. Additionally, van semitrailers are most typically loaded to near their cubic capacity, making estimation of payload c.g. height feasible.

The tractor/van semitrailer combination was also attractive for the special purposes of this study since the nominal trailer lengths, suspension and tire characteristics, and even tractor-related properties are the same as those which would be found in tanker-semitrailer combinations having similar gross weight ratings.

The Sorted BMCS File

The BMCS file was found to contain the following number of total accidents involving three-axle tractors coupled to two-axle van-type semitrailers:

<u>Reporting Year</u>	<u>Total No. of Accidents</u>
1976	6134
1977	6633
1978	8353

The number of single-vehicle rollovers, single-vehicle accidents (of all types), and the percentage of single-vehicle accidents involving rollover are listed in Table 3.3 for each of the three reporting years and for each 2500-lb increment in gross vehicle weight. In this table we see a remarkably consistent increase in the percent rollover involvement with gross vehicle weight over all three years of the data record. At the top of the table are the data entries for empty or virtually empty vehicles, showing on the order of a 2-percent involvement in rollovers among single-vehicle accidents. At the bottom of the table

Table 3.3. Number of Single-Vehicle Overturns, Single-Vehicle Accidents, and the Percentage of Single-Vehicle Accidents Involving Rollover for the Years 1976, 1977, and 1978. From BMCS Data File.

GVW (Thous. Lbs)	1976			1977			1978			Total		
	No. of OT	No. of SV Accid.	% of OT in SV Accid.	No. of OT	No. of SV Accid.	% of OT in SV Accid.	No. of OT	No. of SV Accid.	% of OT in SV Accid.	No. of OT	No. of SV Accid.	% of OT in SV Accid.
27.5 - 30	2	130	1.5	3	132	2.3	3	154	1.9	8	423	1.9
30 - 32.5	3	79	3.8	6	92	6.5	6	138	4.3	15	309	4.8
32.5 - 35	1	55	1.8	3	70	4.3	6	89	6.7	10	214	4.7
35 - 37.5	1	34	2.9	3	42	7.1	7	65	10.8	11	141	7.8
37.5 - 40	5	55	9.1	5	67	7.5	6	80	7.5	16	202	7.9
40 - 42.5	5	50	10	5	47	10.6	7	51	13.7	17	148	11.5
42.5 - 45	3	59	5.1	8	60	13.3	10	68	14.7	21	187	11.2
45 - 47.5	2	42	4.8	6	55	10.9	18	78	23.1	26	175	14.9
47.5 - 50	8	59	13.6	12	82	14.6	13	92	14.1	33	233	14.2
50 - 52.5	7	57	12.3	11	65	16.9	14	78	17.9	32	200	16.0
52.5 - 55	11	56	19.6	18	80	22.5	22	95	23.2	51	231	22.1
55 - 57.5	9	61	14.8	15	81	18.5	22	95	23.2	46	237	19.4
57.5 - 60	9	64	14.1	27	89	30.3	35	126	27.8	71	279	25.5
60 - 62.5	12	60	20	21	75	28.0	27	79	34.2	60	214	28.0
62.5 - 65	31	127	24.4	23	87	26.4	45	143	31.5	99	357	27.7
65 - 67.5	25	106	23.6	36	116	31.0	43	160	26.9	104	382	27.2
67.5 - 70	46	202	22.8	97	269	36.1	126	327	38.5	269	798	33.7
70 - 72.5	64	230	27.8	93	296	31.4	121	387	31.3	278	913	30.5
72.5 - 75	39	155	25.2	70	220	31.8	106	295	35.9	215	670	32.1
75 - 77.5	9	30	30	17	40	42.5	20	60	33.3	46	130	35.4
77.5 - 80	9	21	42.9	18	45	40	23	68	33.8	50	134	37.3

are data representing vehicles running at the maximum levels of gross weight allowed in most states, showing an approximate 37 percent incidence of rollovers among single-vehicle accidents.

Location of Vehicle Center of Gravity Height

The three-axle tractor and two-axle van semitrailer combination was represented in the analysis of rollover thresholds by means of the characterizing parameters shown in Figure 3.2. The figure shows values of sprung and unsprung weights which correspond to typical vehicles as well as heights of placement of the mass centers of each vehicle element. The placement of payload c.g. height in the trailer, however, is a crucial parameter which can vary over a substantial range of values. If a very dense material was loaded onto the trailer floor, for example, the payload c.g. would be located at 55 to 60 inches above the ground. On the other hand, if the trailer's cubic capacity was filled with a homogenous type of freight, the payload c.g. height would be at about 110 inches. For commonly mixed loads, even though the cubic capacity of the trailer may be filled, the payload c.g. is lowered by placing the denser freight on the bottom of the load.

Shown in Figure 3.3 is a plot of the rollover threshold of the tractor-van semitrailer combination versus gross vehicle weight for four different values of payload c.g. height. (The static roll plane model described in Section 4.1.3 was employed for generating the indicated curves.) It was desired that one such curve be selected for use, representing an average payload c.g. height with which to match rollover thresholds to the BMCS accident data.

The selection of the "appropriate" payload c.g. height was made by noting that one type of tractor-semitrailer represented in the BMCS file was of such a nature that its payload c.g. height and overall rollover threshold could be rather closely estimated. This vehicle was the three-axle tractor/two-axle semitrailer employing a tank for transporting hazardous liquids in bulk. In the fully loaded state (75,000 to 80,000 lb gross weight), this vehicle type shows 165 single-vehicle accidents over the years 1976, 1977, and 1978 in the BMCS file. Of these, 84

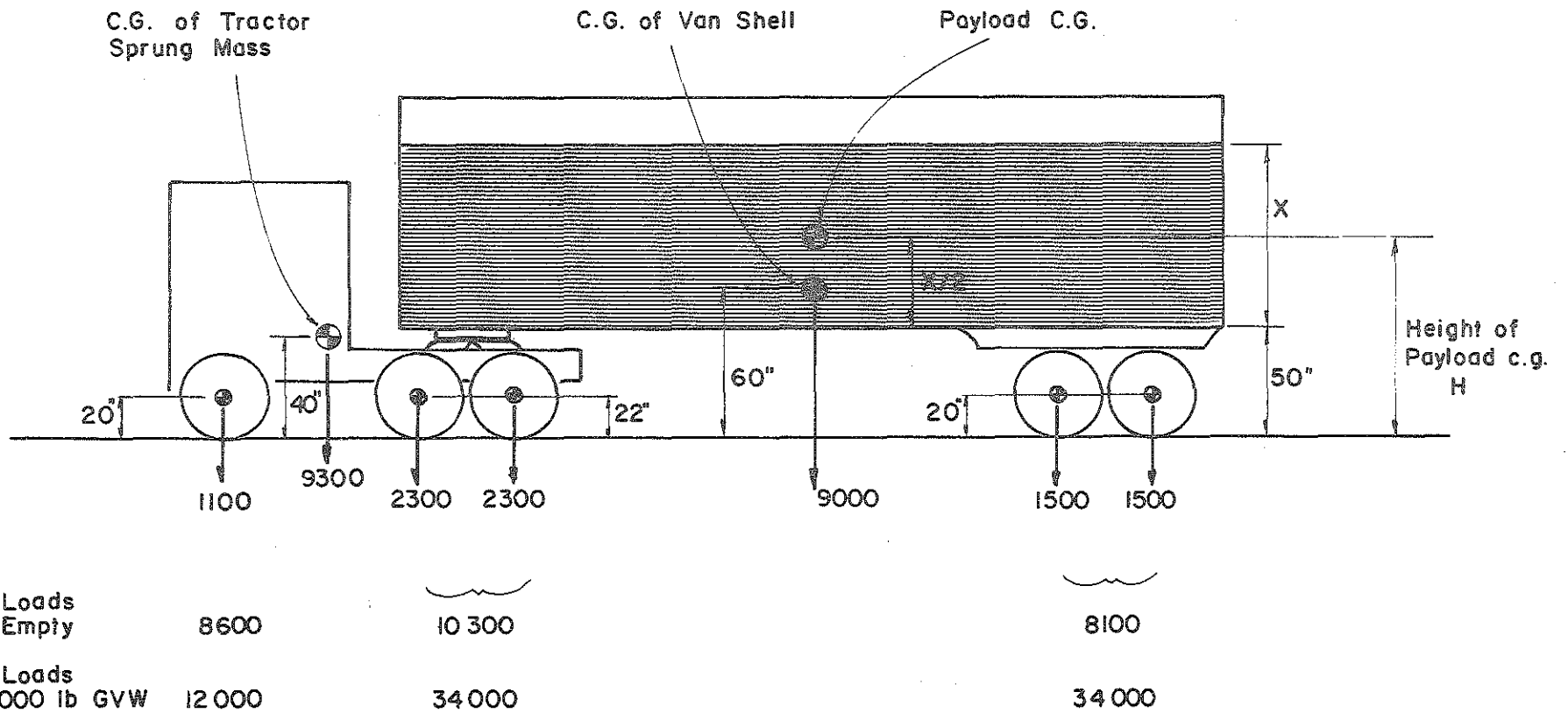

Figure 3.2. Parameters representative of a three-axle tractor and two-axle van semitrailer combination.

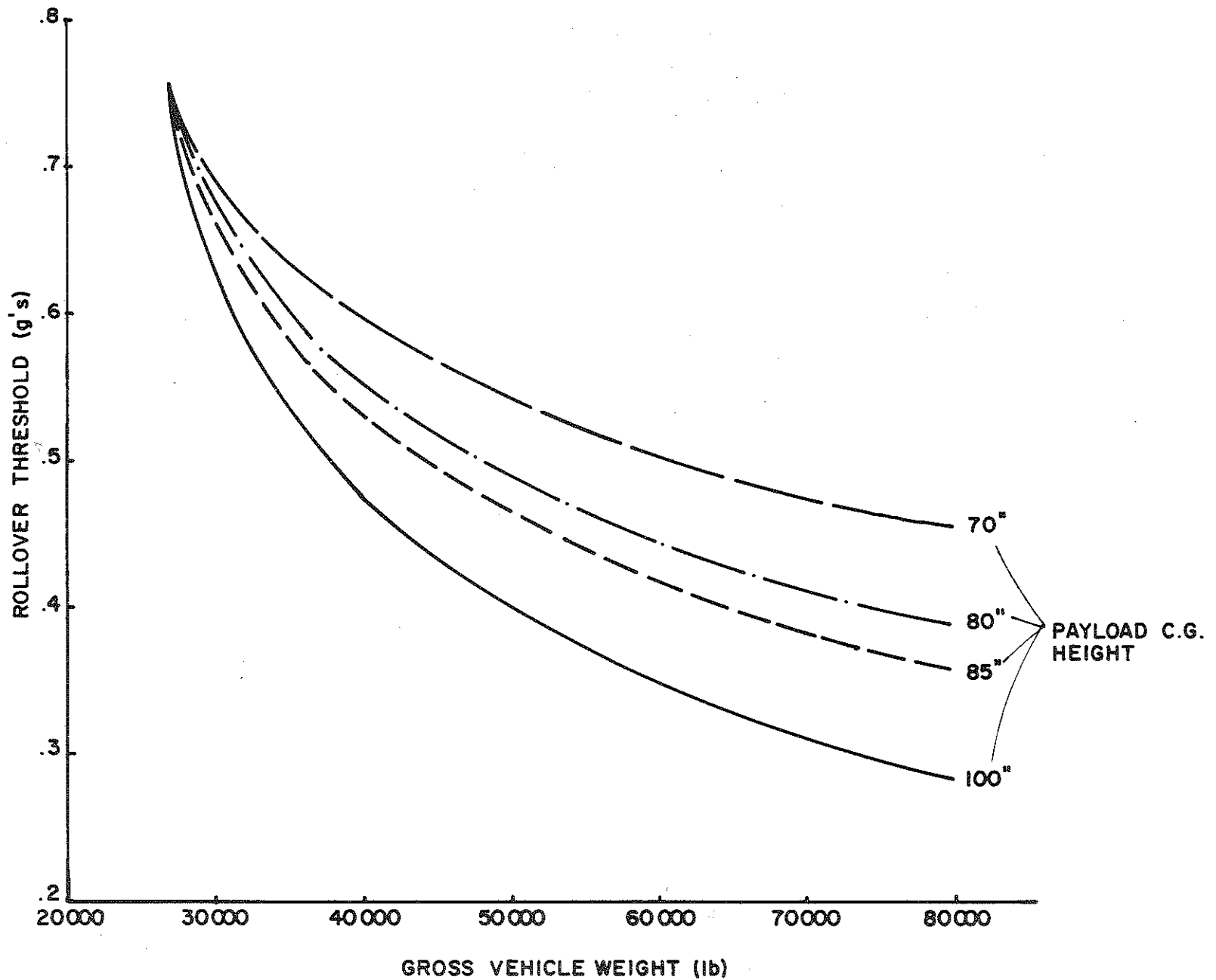

Figure 3.3. Influence of gross vehicle weight on the rollover threshold of the three-axle tractor and two-axle van semitrailer combination.

accidents (or 50.9 percent) involved rollover. This vehicle category is predominantly represented by petroleum and chemical tankers, all of which employ tank c.g. heights which fall within a narrow range of one another.

When such vehicles are operated in their fully loaded state, such that no fluid sloshing is present, their behavior characteristics will be virtually identical to those of the tractor-van semitrailer combination having the same rollover threshold. We assume, then, that such tank vehicles, being also involved in an interstate commerce type of application, should be experiencing rollovers at a rate which agrees with the pattern of rollover involvement of the tractor-van semitrailers in the BMCS file. Placing the rollover accident rate and computed rollover threshold value for the fully loaded tank vehicle on the plot of Figure 3.4, a selection was then made of that value of average payload c.g. height which gives the best extrapolated fit of the van trailer data to the tank trailer data point.

The analysis shows that the very tightly grouped van trailer data fall in line with the single tank trailer data point when a value of 80 inches is used for the average height of the payload c.g. in the three-axle tractor/two-axle van semitrailer combination. Further, we observe that this answer is a most reasonable one given that most van trailer loads are such that the trailer's full cubic capacity is utilized, but a large fraction of transport work done by the common carriers involves mixed loads which pull down the c.g. below the level achieved with homogeneous freight. Additionally, the substantial fraction of transport miles covered by trailers with less than full cube loading also tends to moderate the payload c.g. height.

Figure 3.4 reveals that the dependence of rollover accident involvement upon the vehicle's rollover threshold, as loaded, is not only a monotonic relationship, but also illustrates, as averaged, a remarkably tight pattern of data. Most notably, we see that the relationship becomes very steep at the lower range of rollover threshold. We suggest that such a steep sensitivity is to be expected since the lowering of rollover threshold into this range brings the vehicle's performance limit

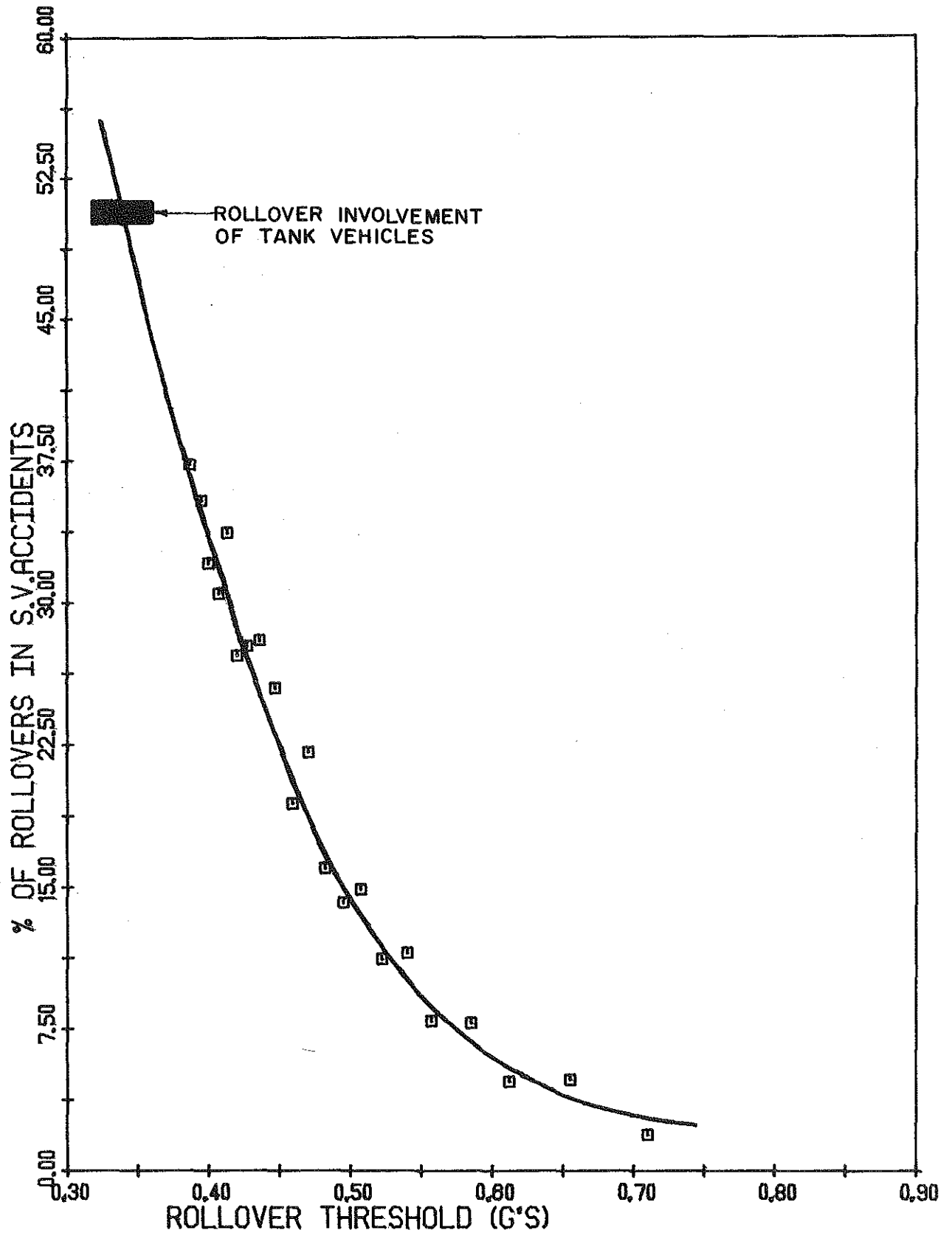

Figure 3.4. Relationship between rollover threshold and rollover accident involvement. (Based on BMCS accident data for the years 1976-78.)

into near proximity with normal levels of maneuvering acceleration. If a vehicle with a 0.1 g rollover threshold were driven normally, for example, it would be expected to suffer rollover every few miles (or in 100 percent of its single-vehicle accidents).

One question that was posed regarding the general applicability of the relationship shown in Figure 3.4 involved the matter of the predominance of travel on interstate-quality roads represented in the BMCS file. Since the BMCS has jurisdiction over interstate carriers only, a large fraction of the accidents represented in the file occurred on interstate and other divided highways for which the off-highway environment appears conspicuously less threatening to rollover than is the case for the typical design of non-divided highways.

In examining this question, we had hypothesized that divided, interstate-quality roads would show a more consistent sensitivity of rollover involvement to the level of the vehicle's rollover threshold since the roadside typically involves gradual slopes on shoulder and berm areas, thus permitting the generation of medium level lateral accelerations instead of the harsh "tripping" kinds of accelerations which might derive from the less "groomed" roadside features of undivided highways. "Tripping" accelerations would roll over virtually all vehicles, it was reasoned, while a more moderate distribution of acceleration conditions would tend to produce rollovers in relation to each vehicle's inherent rollover threshold. Thus, another screening of the BMCS file was done to produce a comparison of the rollover involvement versus rollover threshold relationships obtained for the selected tractor-semitrailer on divided and undivided highways, individually. As shown in Figure 3.5, no major distinctions can be made between the data applying to the two roadway types. Accordingly, it would seem that the rollover involvement/rollover threshold relationship is a rather basic characteristic which applies as a general predictor for vehicles of the generic type selected.

Moreover, the plot shown previously in Figure 3.4 has been employed in this study as a basis for predicting, in Section 6, the rollover risks posed by each of the recommended Advanced Michigan Tankers.

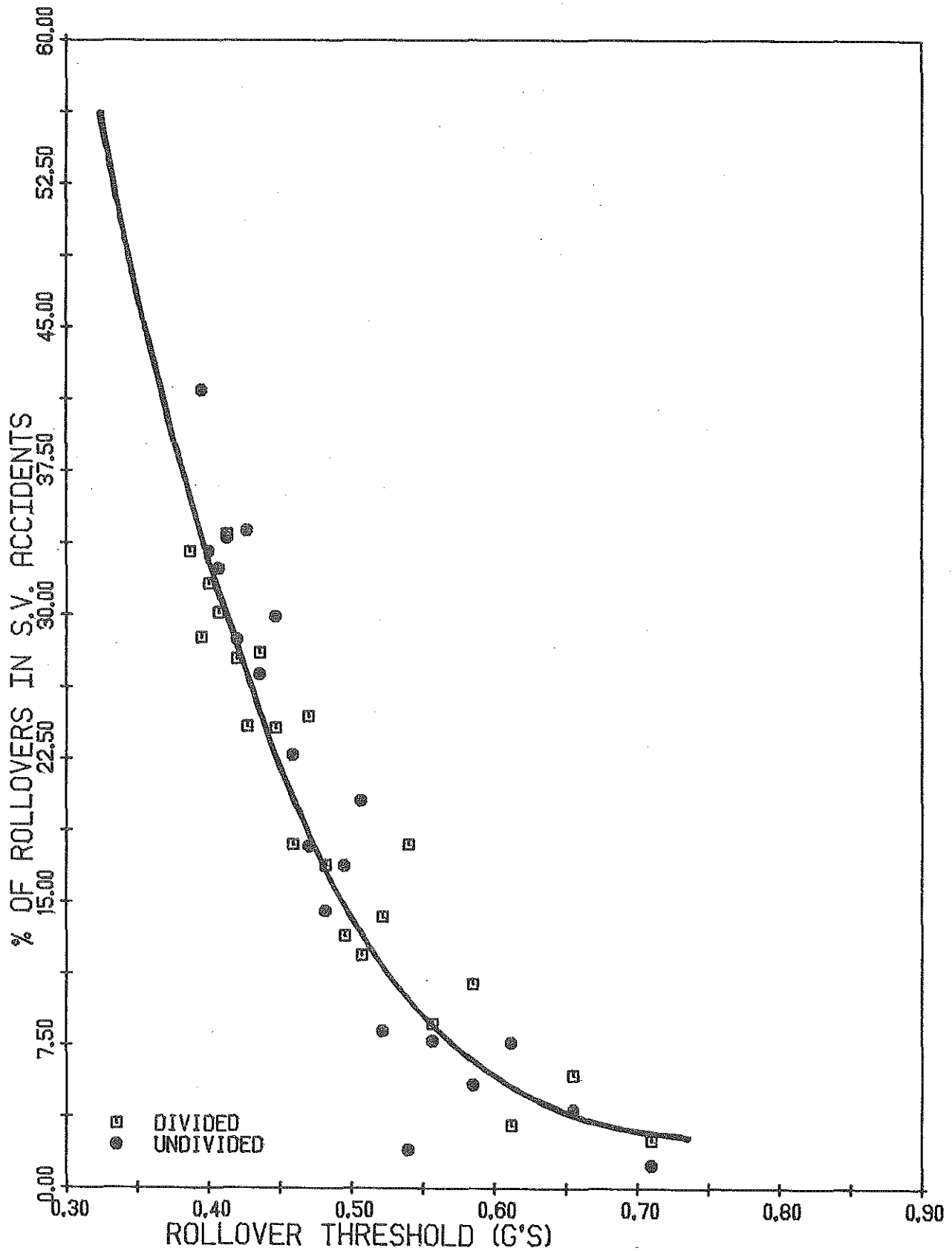

Figure 3.5. Comparison of the rollover involvement of tractor-semitrailers on divided and undivided highways.

3.3 Michigan File

Michigan truck accident data for 1978 were examined to identify the types of collisions involving tractor-semitrailers. For the purposes of this analysis, truck accidents have been classified into six basic categories, namely:

- 1) single vehicle
- 2) head on
- 3) rear end
- 4) side swipe
- 5) two vehicles colliding at an angle
- 6) multiple vehicle

We observe that the fraction of accidents which fall into each category is dependent on the type of roadway on which the accident occurs and the density of the traffic. Thus, the data revealing accident types have been divided according to roadway type and population density of the region of the accidents. Three types of roadways were considered, namely: (1) freeways, (2) U.S. and Michigan highways, and (3) county roads and city streets. Histograms depicting the fractional distribution of the type of collisions that occur on each of the three roadway types are shown in Figures 3.6, 3.7, and 3.8, respectively. In each figure, the fractional distributions of accident type are given for two population zones—populations of less than 5,000, which are considered to represent rural areas, and populations greater than 5,000, which are considered to represent an urban traffic environment.

From the point of view of tanker overturns, the accidents of greatest interest are the single-vehicle accidents. The highest percentage of single-vehicle accidents are seen to occur on rural freeways. Urbanized areas, conversely, show consistently lower levels of single-vehicle accidents.

The illustrated breakdown of accident data are employed in Section 6.4 for determining the overturn rates of candidate gasoline tanker configurations, given an estimate of the tanker miles traveled on the various respective road types and population zones.

ACCIDENTS ON INTERSTATE FREEWAYS

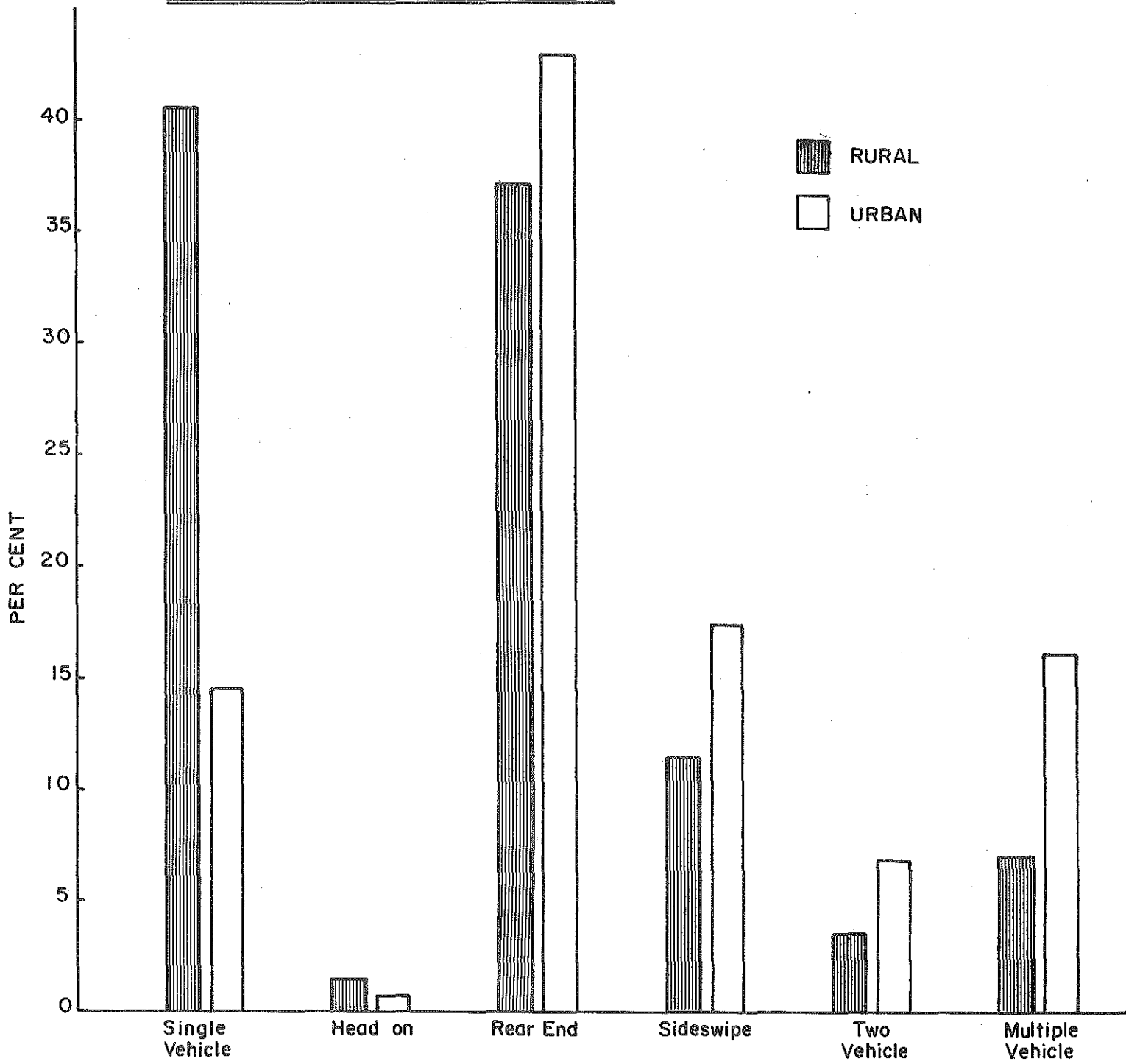

Figure 3.6

ACCIDENTS ON U.S. & MICHIGAN HIGHWAYS

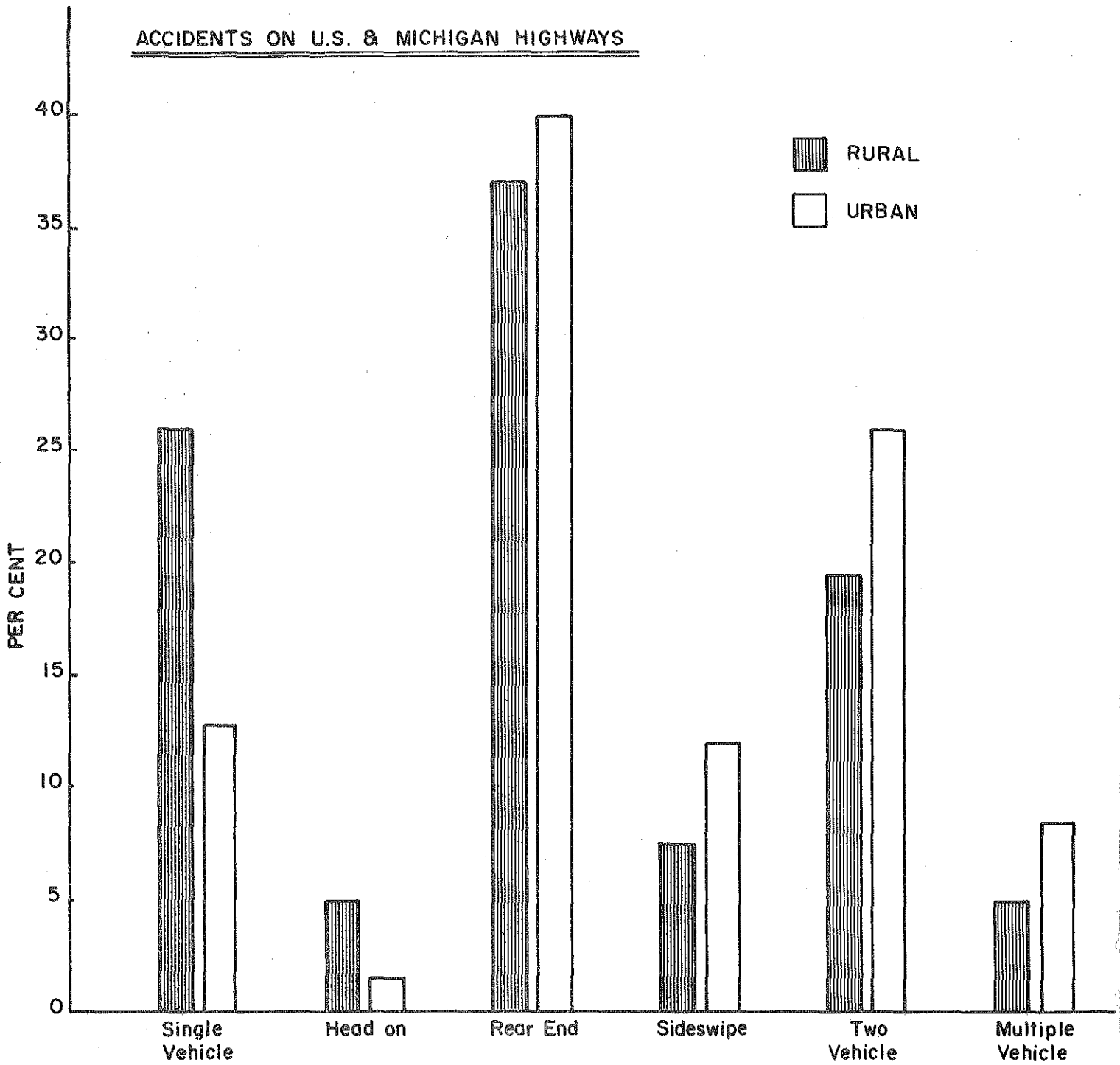

Figure 3.7

ACCIDENTS ON COUNTY ROADS & CITY STREETS

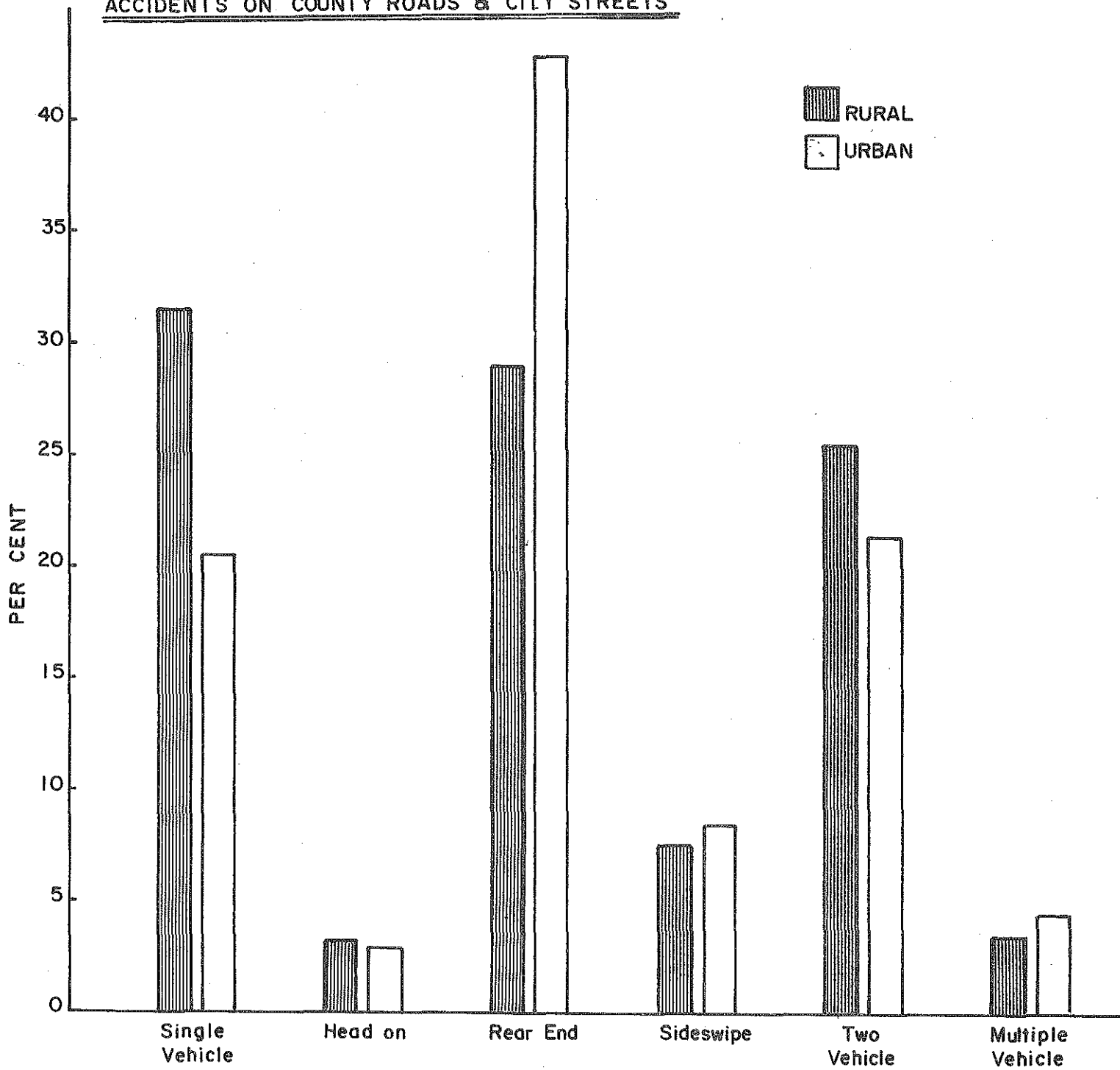

Figure 3.8

3.4 Review of a Study of Gasoline Transportation Risks

A comprehensive study of the risk of transporting gasoline by truck [4] was conducted by the Battelle Pacific Northwest Laboratory in 1978. This research will be briefly reviewed here insofar as it represents the most recent and relevant precursor to the study being reported. In the reference work, fatalities were used as the measure of the risk involved in transporting gasoline.

A two-stage risk model was used for evaluating risk. The first step involved the use of an elaborate "fault tree analysis" for the identification and calculation of the probabilities of each of the various mechanisms by which gasoline could be released into the environment. In the second step, the consequences of the release (in terms of fatalities) were evaluated using a gasoline dispersal and fire spread model. The population density and the weather pattern at the accident site were factored into the model of the environment. Risk was displayed using a "Risk Spectrum" which is a plot of the expected frequency of accidents (accidents/year) as a function of the number of fatalities which result from such accidents.

The risk analysis revealed that, in the year 1980, 55 fatalities should be expected nationwide from accidents involving gasoline trucks. Twenty-nine of these fatalities were expected to be as a direct result of the release of gasoline, and the rest from accident forces which are independent of the hazardous nature of the cargo. The probability of the occurrence of individual accidents which result in large numbers of fatalities was found to be relatively low. For example, accidents which result in 10 or more fatalities were expected to occur in the U.S. only once in about 45 years. In the following paragraphs, the gasoline "Release Mechanisms" and the "consequences of gasoline release" which were analyzed in the Battelle study will be briefly described.

3.4.1 Release Mechanisms. Several mechanisms by which accident forces can fail the integrity of a gasoline tank were identified in the study. A logical analysis of the sequence of events which lead to the failure of the tank was conducted using a fault tree analysis. Failure

mechanisms which result in the release of a significant amount of gasoline are listed in Table 3.4. The fraction of the payload which is released into the environment and the probability of release (given that an accident has occurred) are listed in the table for each of the failure mechanisms.

The probability values listed indicate that failure of tank walls due to puncture, abrasion, and impact account for more than 89 percent of the significant releases of gasoline. According to the Battelle study, release of gasoline through a failed manhole cover accounts for only 2 percent of all the gasoline releases that take place. Release of gasoline through a manhole cover was assumed to occur either due to: (1) a failure of the gasket material upon being exposed to a gasoline pool fire, or (2) due to normal deterioration, or (3) due to faults in assembly or manufacturing of the manhole cover.

(Analysis of gasoline tanker accidents in Michigan has revealed that manhole covers fail much more frequently than has been indicated in the Battelle study. Experiments, conducted as part of this study (see Section 4.3) have also shown that the internal pressure surge that occurs at the moment of impact in a tanker rollover can cause conventional manhole covers to be completely blown off even when in their "brand new" state. Thus, we are unable to reconcile the Michigan tanker accident experience and the confirming experiments with the data concerning tank failure mechanisms which were reported in Reference [4].)

3.4.2 Consequences of a Gasoline Release. In the Battelle study, the consequences of a gasoline release were divided into four categories, each of whose risks were evaluated independently. The total risk posed by release of gasoline was then determined by summing up the risks posed by each of these consequences.

The consequences that were studied covered the following scenarios:

- 1) A gasoline pool is formed by the release of gasoline. The pool catches fire and poses a danger to the vehicle occupant.
- 2) The gasoline pool fire causes secondary fires in adjacent buildings thereby posing a danger to the occupants of the building.

Table 3.4. Probability of Release and Release Fractions for Gasoline Tank Truck Failures.

Release Mechanism	Release Fraction	Probability of Release During an Accident
Failure of Tank Walls Due to Puncture	0.5	0.025
Failure of Tank Walls Due to Pressure	0.5	0.0000000092
Failure of Tank Walls Due to Abrasion	1.0	0.01042
Failure of Tank Walls Due to Impact	0.5 1.0	0.1157 0.1157
Failure of Tank Walls Due to Fire	1.0	0.00016
Release from Faulty Pressure Relief Valve	0.35	0.00278
Failure of Relief Valve Due to Pressure	0.35	0.0007752
Failure of Outlet Valve Due to Fire	1.0	0.0016133
Failure of Outlet Valve from Other Causes	U* 0.5 OT* 0.35	0.0004664 0.0001166
Failure of Manhole Covers Due to Fire	1.0	0.00048
Failure of Manhole Covers From Other Causes	0.35	0.00086

*U - Upright, OT - Overturned

- 3) The gasoline tanker explodes and kills the occupants of all the vehicles involved in the accident.
- 4) The gasoline tanker explodes in an urban area and kills the occupants of buildings adjacent to the accident scene.

The estimated probabilities for the fatalities that can result from each of the four consequences are plotted in Figure 3.9. In this figure, the number of fatalities, n , per accident is plotted on the abscissa and the expected number of accidents per year in which n or more fatalities occur is plotted on the ordinate. An inspection of these risk predictions reveals that most of the accidents which result in one or two deaths are attributable to the first consequence, namely: death of vehicle occupants due to pool fires. Larger consequence accidents, which result in more than five fatalities, are mostly due to consequence four, which involves deaths in adjacent buildings due to explosion.

The contribution of consequences 2 and 3 to the overall risk of transporting gasoline can be seen to be negligible.

Moreover, the cited study served to provide a broad review of the various elements contributing to the risks of transporting gasoline by truck. Insofar as various aspects of the study's data and results did not agree with the Michigan tanker accident experience, however, we have taken another, simpler, approach to predicting risks for the recommended Advanced Michigan Tanker.

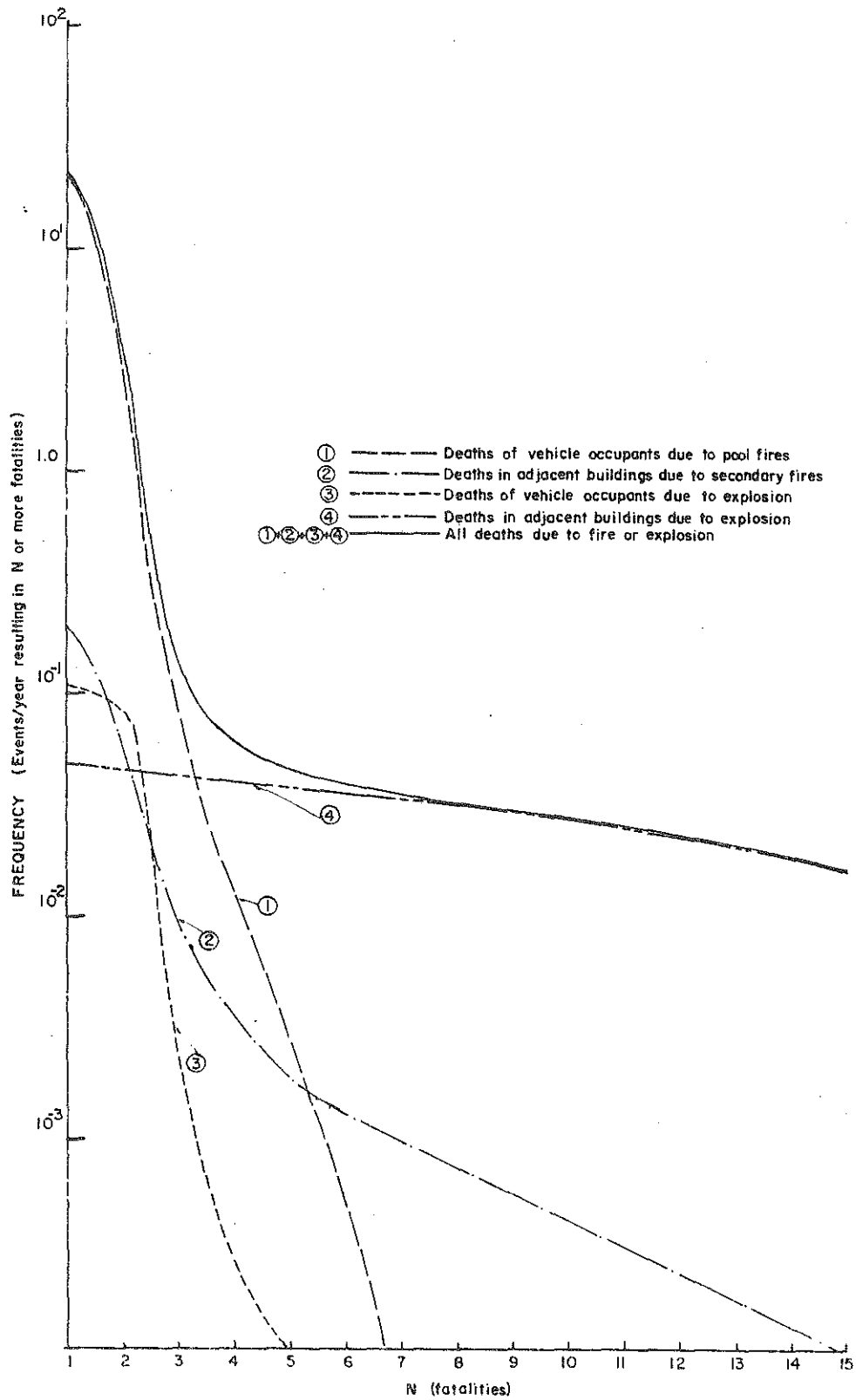

Figure 3.9. Risk spectrum for release of gasoline from tank truck accidents in 1980.

4.0 ANALYSIS OF THE DYNAMIC BEHAVIOR OF CANDIDATE VEHICLE CONFIGURATIONS

The principle task of the study involved mathematically-based analyses of the static and dynamic performance characteristics of candidate tank vehicle configurations. On the basis of performance characteristics, the list of vehicle types under consideration was reduced to the four configurations which have been recommended. The analysis task addressed three principle subjects, namely:

- 1) analysis of the yaw and roll behavior of a comprehensive set of candidate vehicles (presented in Section 4.1),
- 2) an examination of the sensitivity of vehicle roll stability to a number of basic design parameters which are common to virtually any configuration of tank vehicle (in Section 4.2), and
- 3) analysis of the influence of a sloshing liquid load on the roll stability of partially-loaded tankers (in Section 4.3).

4.1 Analysis of the Yaw and Roll Behavior of Candidate Vehicle Configurations

A set of candidate vehicles was selected and subsequently screened on the basis of yaw and roll performance measures which were defined. The assembly of parameter sets describing each of the candidate vehicles is presented in Section 4.1.1. In the following subsections, the candidate vehicles are evaluated on the basis of both static and dynamic response characteristics using various computerized simulation techniques. As each category of performance is discussed, the deficiencies associated with various vehicle configurations are cited, establishing the basis for later reduction of the "candidate" list to only those vehicles offering high levels of performance in all categories.

4.1.1 Candidate Vehicle Configurations. The vehicles evaluated in this study can be classified within two basic groups: (1) tractor-semitrailers and (2) double tankers of the tractor-semitrailer-semitrailer type

(hereinafter referred to as the TSS configuration). Conventional doubles combinations equipped with a dolly and pintle hook type connection for the full trailer were ruled out since a preliminary analysis, as well as the experience gained from the Michigan double tanker study [2], indicated that the relatively short type of conventional double cannot achieve dynamic rollover immunity qualities which are comparable to those of either the tractor-semitrailer or the TSS configurations.

Schematic diagrams of the candidate tractor-semitrailer combinations are shown in Table 4.1. The vehicles shown in the table range in capacity from 8,090 gallons for a two-axle semitrailer to 16,150 gallons for an eight-axle arrangement. The tank length was limited to 45 feet in these designs. The location and loading pattern for the axles were configured to meet the existing Michigan laws.

The TSS combinations were configured in both the 59-foot and 65-foot overall length versions, both of which are permitted by the existing Michigan law. (The latter is currently being permitted only on specially designated highways.) The TSS configurations are shown in Table 4.2.

It was necessary to make several assumptions in the process of arriving at the final design of each of these vehicle configurations. Each assumption and the corresponding rationale will be discussed below.

Length and Wheelbase Considerations

One straightforward means of lowering the c.g. height of a tanker vehicle is by increasing its length. The tank length is limited by two constraints—(1) an overall length limit posed by road-use laws and (2) low-speed offtracking considerations which limit the wheelbase and hence the overall length of the tank.

Michigan's road-use laws limit the length of the semitrailer portion of a tractor-semitrailer combination to 45 feet.

A second length constraint derived from the position that the low-speed offtracking performance of the candidate tractor-semitrailer layouts would be equal to or better than that of a typical 8,800-gallon capacity tanker (which meets the MC306 specifications). By this latter constraint, semitrailer wheelbases were kept within 406 inches. (Trailer wheelbase is defined as the longitudinal distance from the fifth wheel

Candidate Tractor/Semitrailer Combinations
TABLE 4.1

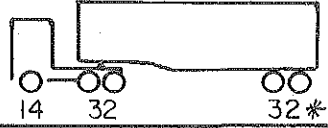
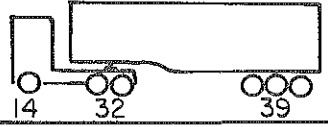
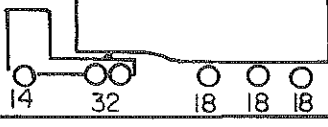
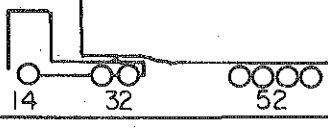
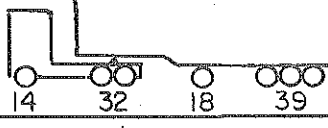
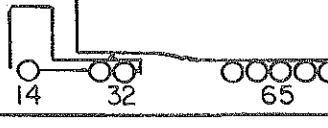
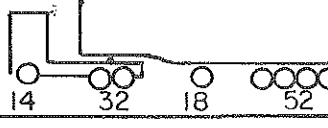
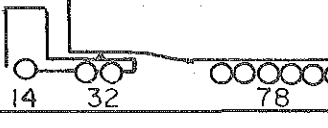
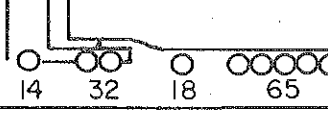
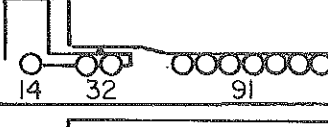
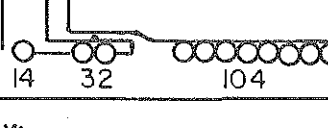
#	SCHEMATIC DIAGRAM	LOADED WEIGHT (lbs)	EMPTY WEIGHT (lbs)	PAYLOAD CAPACITY (gal)
1		78 000	28 670	8 090
2a		85 000	31 750	8 730
2b		100 000	33 920	10 830
3a		98 000	35 720	10 210
3b		103 000	36 420	10 915
4a		111 000	39 570	11 700
4b		116 000	40 360	12 400
5a		124 000	43 600	13 180
5b		129 000	44 330	13 880
6		137 000	47 510	14 670
7		150 000	51 490	16 150

*Load carried by the axle sets in the units of thousands of pounds.

Candidate Tractor/Semitrailer/Semitrailer Combinations

TABLE 4.2

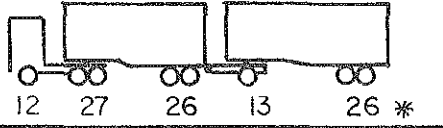
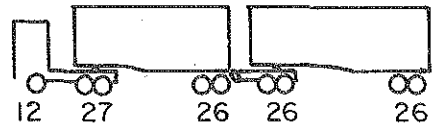
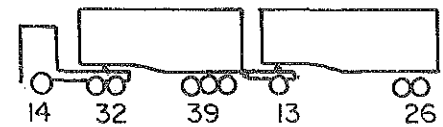
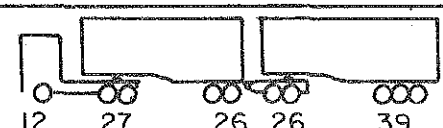
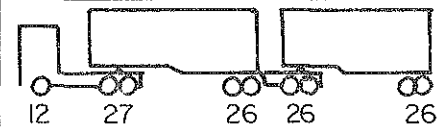
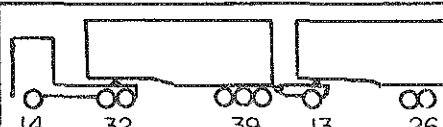
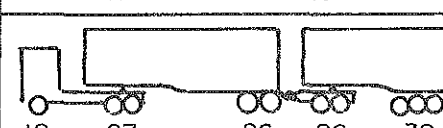
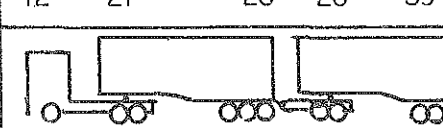
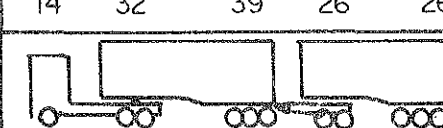
#	SCHEMATIC DIAGRAM	LOADED WEIGHT (lbs)	EMPTY WEIGHT (lbs)	PAYLOAD CAPACITY (gallons)		
				SEMI TRAILER	PUP TRAILER	TOTAL
<u>59' OVERALL LENGTH</u>						
I		104 000	39160	6260	4370	10 630
IIa		117 000	43190	6260	5840	12100
IIb		124 000	44 090	8730	4370	13100
III		130 000	47100	6260	7330	13590
<u>65' OVERALL LENGTH</u>						
IVa		117 000	43190	6260	5840	12100
IVb		124 000	44 090	8730	4370	13100
V		130 000	47100	6260	7330	13590
VI		137 000	48120	8730	5840	14570
VII		150 000	52030	8730	7330	16060

* Load carried by the axle set in the units of thousands of pounds.

to the midpoint of the semitrailer axles.) For semitrailers equipped with more than two axles, the axles were configured such that the wheelbase would be less than or equal to 406 inches (see Fig. 4.1), even when the foremost semitrailer axle was considered to be lifted up, as with an air-lift, air-suspended axle.

The tank lengths on the first three semitrailer layouts (#1-#2b) were limited by the wheelbase constraint, while the tank length of the last eight configurations (#3a-#7) were limited by the overall length limit of 45 feet.

All of the candidate TSS configurations had low-speed offtracking qualities which were superior to the 8,800-gallon MC306 tanker. The 59-foot and 65-foot versions of the double tankers were therefore laid out by making full use of their respective overall length limits.

Tank Cross-Section Geometry

Improvements in rollover threshold can be achieved by utilizing tank cross-sectional profiles which lower the overall height of the vehicle. The tank cross-section which was used for calculating the cross-sectional area and c.g. heights of the candidate vehicles is shown in Figure 4.2. The radius of the tank shell was set at 89 inches for the top, bottom and the sides. The blend radius was assumed to be 15 inches. A more complete discussion of tank cross-section geometry is included in Section 4.2.1. A computer program which was developed for the purpose of computing tank cross-sectional areas and axle layouts of the tankers is described in Appendix E.

Tank Shell Material and Empty Vehicle Weight

The tank shell was assumed to be 10-gauge HSLA (high strength, low alloy) steel. Based on data describing several steel tanks manufactured by the Fruehauf Corporation, the shell was estimated to weigh 0.98 pounds per gallon of shell volume. Each trailer axle was assumed to weigh 1500 lb. The combined weight of the under-construction and suspension springs was estimated to be 900 lb/axle.

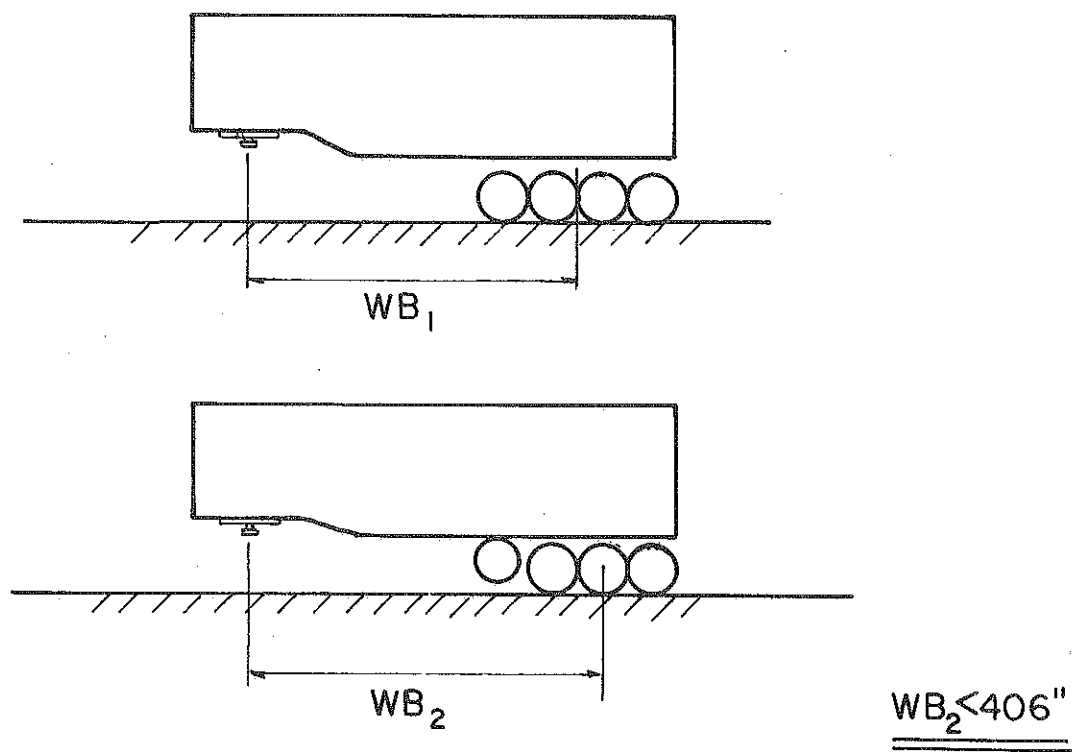

Figure 4.1. Changes in wheelbase produced by a lifting up of the foremost semitrailer axle.

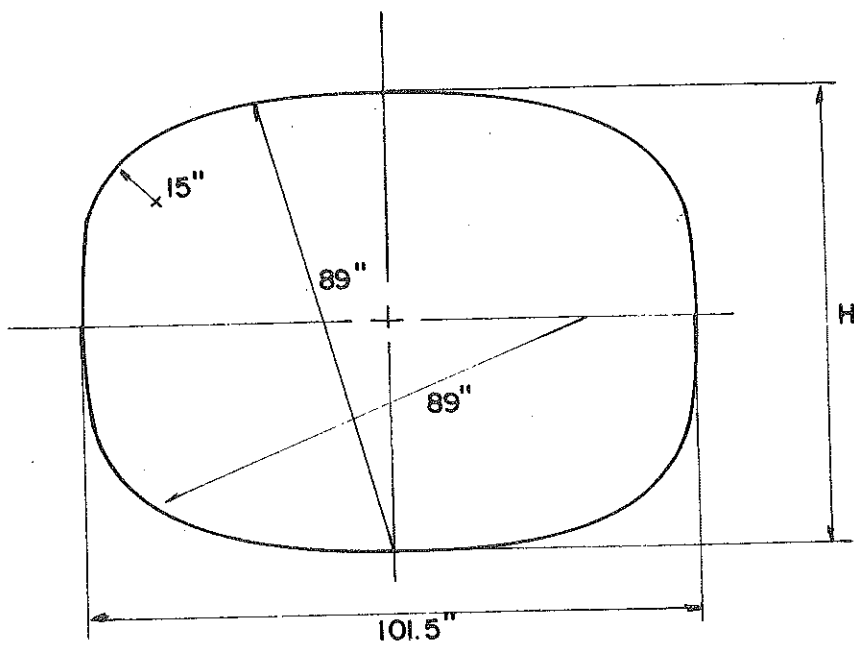

Figure 4.2. Tank cross-section geometry for the Advanced Michigan Tanker.

Arrangement for Connecting the Semitrailers of the TSS Configurations

For TSS configurations, the dolly and pintle hook arrangement of conventional-style doubles is replaced by an arrangement which is shown in Figure 4.3. As seen in the figure, a shelf-like element is fastened to the lead semitrailer and is constrained to pitch about the axis A-A with respect to this semitrailer. A conventional fifth wheel is mounted on this element and is connected to the second semitrailer. The static vertical load acting on this fifth wheel arrangement is carried completely by the axles under the shelf, such that no vertical load is transmitted to the first semitrailer through the hinge AA.

Since the hinge connection between the first semitrailer and the shelf is virtually rigid in both roll and yaw, the shelf element is considered to be an integral portion of the semitrailer, as represented in a yaw/roll simulation model to be discussed later.

Tank Bottom Height

The bottom height of the tank is limited by (1) the height of the fifth wheel arrangement at the front of the trailer and (2) the height of the chassis at the rear.

Tractor fifth wheel height is typically around 50 inches above ground level. If a height of 6 inches is allowed for the structural members which are mounted at the bottom of the tank shell, the overall height of the tank bottom would be limited to 56 inches in the vicinity of the tractor fifth wheel. The bottom of the tank at the rear of the semitrailer was taken to be a minimum of 46-1/2 inches, on the basis of liaison with tank industry sources.

As shown in Figure 4.4, the bottom of the tank must be sloped slightly to the rear if the contents of the tanks are to be easily drained by gravity. In keeping with common industry practice, a slope of 5 inches over the entire length of the tank was assumed for the candidate vehicles. Maximum lowering of the tank center of gravity was achieved, given the various constraints, by use of a 4-1/2-inch drop section aft of the fifth wheel coupler area.

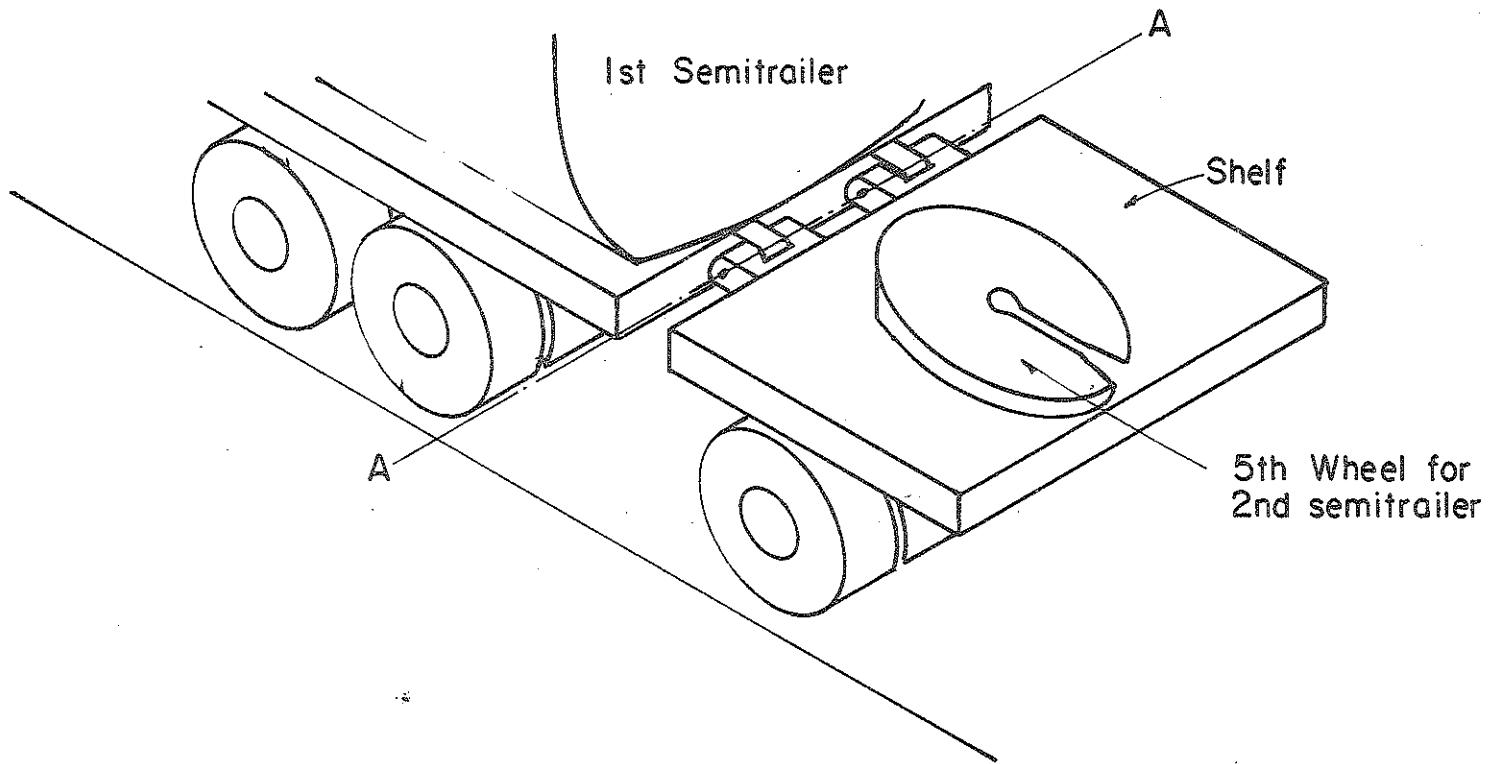

Figure 4.3. Arrangement for connecting the semitrailers of the TSS configurations.

In the case of the second semitrailer of the TSS configurations, a height of 54 inches above ground level was assumed for the fifth wheel plate and a bottom height of 60 inches above ground level for the front end of the tank shell. The bottom of the second semitrailer is assumed to drop to a height of 46-1/2 inches at the rear end. The side view of a TSS configuration is shown in Figure 4.5.

Dished Ends

All calculations were performed assuming that a uniform tank cross-section exists over each portion of the tank having a given section height. The presence of dished or contoured heads at the front and rear of the tank, however, serve to reduce the effective cross-sectional area at each end. This loss in shell volume was accounted for in the calculation of shell volume by simply subtracting 9 inches from the nominal length of the tank on each end.

Fifth Wheel Loads and Axle Loads - Tractor-Semitrailer

The tractor fifth wheel load for the tractor-semitrailer configuration was set at 31,000 lbs. Assuming a total tractor weight of 15,000 lbs, the loaded tractor-semitrailer produced a 14,000-lb axle load on the tractor front axle and 32,000 lbs on the tractor rear tandem. See Figure 4.6.

The semitrailer axles, which are assumed to be spaced 44 inches apart (in the longitudinal direction), are loaded to 13,000 lbs each, while the "spread" axles are located 108 inches apart and are loaded to 18,000 lbs.

Tractor-Semitrailer-Semitrailer Configurations

Four of the TSS configurations (#IIb, #IVb, #VI, #VII) were designed with a three-axle set (loaded to 39,000 lbs) on the first semitrailer. These configurations were assumed to carry a tractor fifth wheel load of 31,000 lbs, thereby producing the same load distribution for the tractor axles as that cited above for the tractor-semitrailer configuration.

The rest of the five TSS configurations (#I, #IIa, #III, #IVa, #V) were designed with two axles on the first semitrailer.

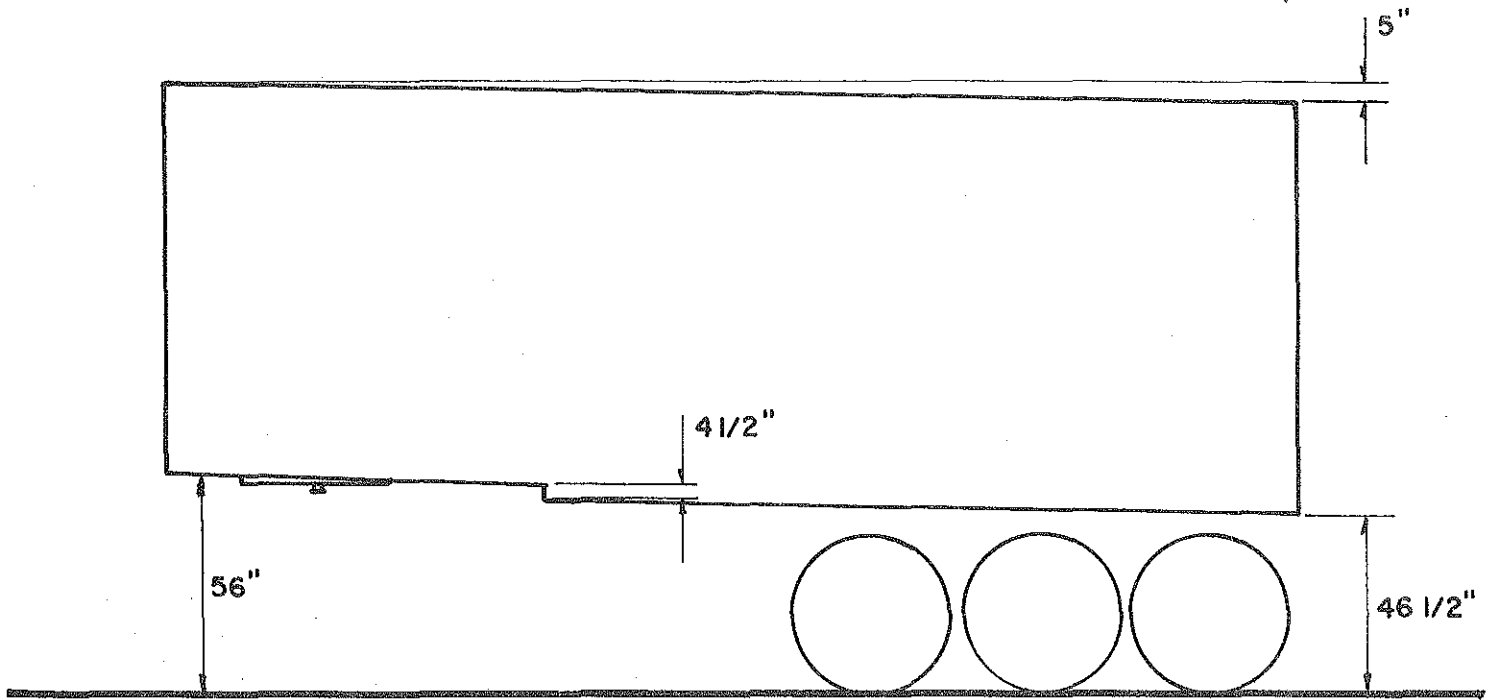

Figure 4.4. Tank bottom heights for the tractor-semitrailer configurations.

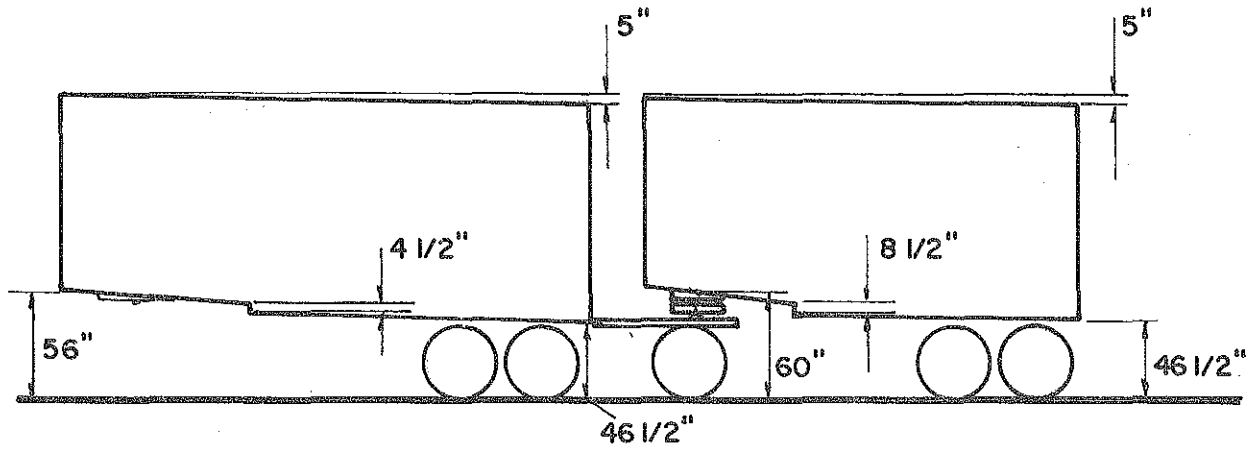

Figure 4.5. Tank bottom heights for the TSS combinations.

Since, in these cases, the axles on the lead semitrailer carry a total load of only 26,000 lbs, the tractor fifth wheel load was reduced to 24,000 lbs. The load distribution for the tractor axles of these five TSS configurations is shown in Figure 4.7.

4.1.2 Low-Speed Maneuverability. Good low-speed maneuverability was seen as an essential quality for a tanker transporting gasoline. Gasoline tankers need to travel through city streets, and also gain easy access to the storage tank filling ports at service stations. Indeed, excellent low-speed maneuverability had been one of the main reasons for the popularity of a double-bottom tanker configuration in Michigan. It was known from the outset, however, that high levels of maneuverability are typically gained at the expense of directional stability. Since a high premium was being placed, here, on vehicle stability, it was clear that poorer low-speed maneuverability would be attained than that afforded by the previously popular double-bottom tanker.

Two low-speed maneuvering properties of articulated vehicles were addressed in the study. These properties characterize (1) the low-speed offtracking obtained in a constant radius turn and (2) the lateral force needed at the tractor fifth wheel to sustain a steady turn at low forward speeds. Numerics based on these two maneuvering qualities are used to compare the candidate tractor-semitrailer and tractor-semitrailer-semitrailer configurations described in the preceding section.

In the discussion that follows, the maneuverability of articulated vehicles equipped with single axles (on each trailing unit) is first analyzed. Following this, the influence of multiple axles on low-speed maneuverability will be discussed.

Low-Speed Offtracking and Lateral Fifth Wheel Forces for Single-Axle Trailers

During low-speed maneuvers, trailer axles offtrack towards the center of the turn. That is, trailer axles will inscribe a path falling to the inside of the path taken by the tractor axles. The amount of offtracking is dependent not only on the length of the vehicle, but also

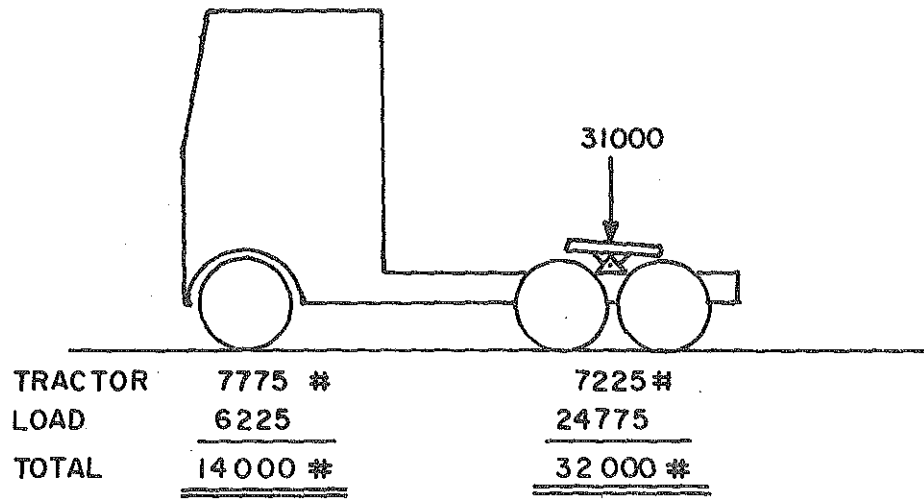

Figure 4.6. Tractor axle loads for a fifth wheel load of 31,000 lbs.

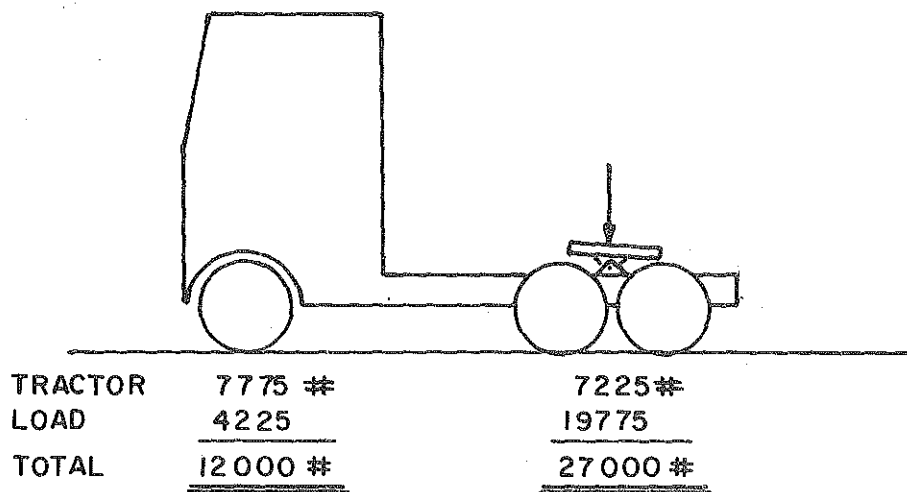

Figure 4.7. Tractor axle loads for a fifth wheel load of 24,000 lbs.

on the number of articulation points and the layout of the axles. Vehicles which exhibit large amounts of offtracking tend to be difficult to maneuver in situations where it is necessary to execute sharp turns around obstacles. Figure 4.8 illustrates the offtracking of a tractor-semitrailer and a tractor-semitrailer-semitrailer combination during a steady turn characterized by the path radius, R_1 , of the tractor fifth wheel.

During low-speed maneuvers, the lateral acceleration levels are sufficiently low such that the D'Alembert forces in the lateral direction can be neglected. Hence, the sum of the lateral forces acting on the vehicle through the tire-road interface is zero during a low velocity steady turn. For the case where there are only single axles on each trailer, the lateral tire forces are statically determinate. Hence, the lateral tire force produced at each individual axle is zero. The tires therefore operate at zero sideslip, and the trajectory of the axles at steady state is perpendicular to their respective turn radius vectors. It follows, of course (for single-axle trailers), that no lateral force is needed at the tractor fifth wheel to sustain a steady turn at low forward velocities.

As shown in Figure 4.8, the offtracking during a steady turn can be computed from simple planar geometry. The radius of turn, R_2 , of the semitrailer axle is given by the expression:

$$R_2^2 = R_1^2 - x_1^2 \quad (4.1)$$

The radius of turn, R_3 , of the rearmost axle of the TSS configuration is given by the expression:

$$R_3^2 = R_1^2 - x_1^2 - x_2^2 + (b_1 - x_1)^2 \quad (4.2)$$

where x_1 , x_2 , and b_1 are illustrated in Figure 4.8. It can be seen from (4.1) and (4.2) that the amount of offtracking ($R_1 - R_2$) or ($R_1 - R_3$) is dependent not only on the vehicle dimensions x_1 , x_2 , and b , but also on the radius of turn, R_1 .

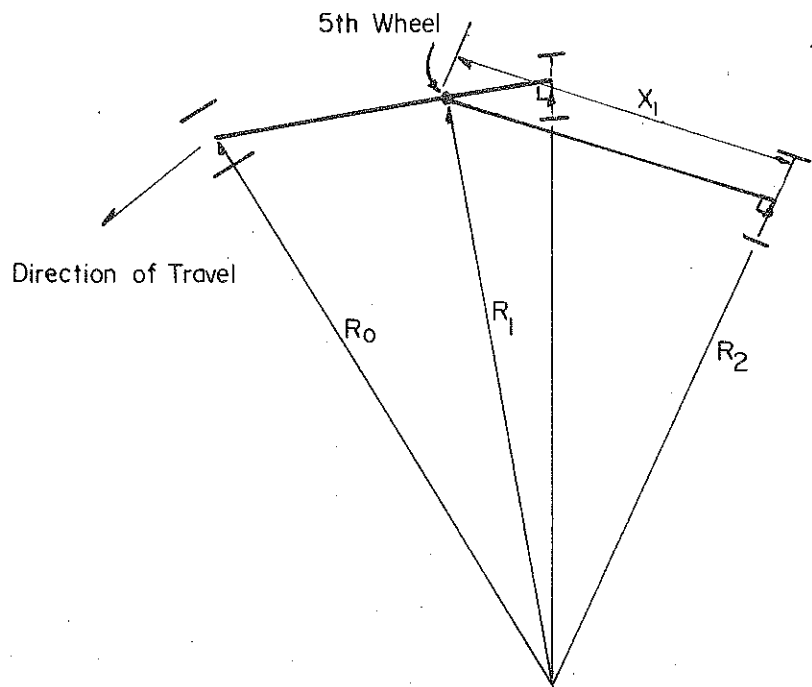

TRACTOR SEMI-TRAILER COMBINATION

$$\underline{R_2^2 = R_1^2 - X_1^2}$$

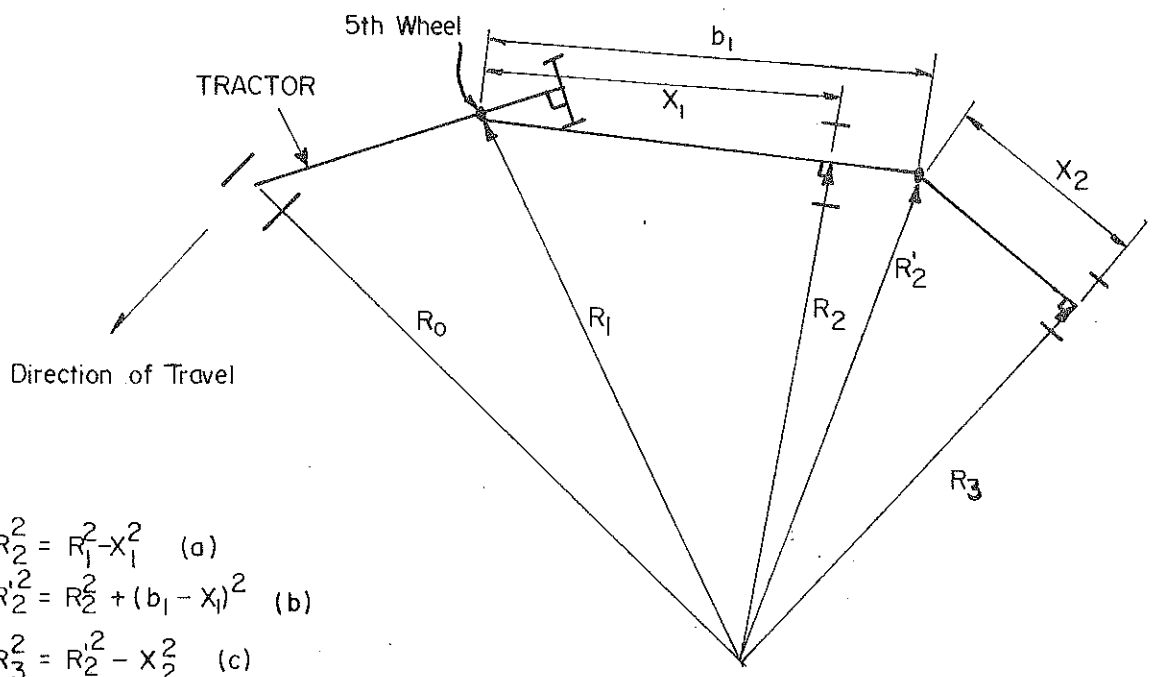

$$R_2^2 = R_1^2 - X_1^2 \quad (a)$$

$$R_2'^2 = R_2^2 + (b_1 - X_1)^2 \quad (b)$$

$$R_3^2 = R_2'^2 - X_2^2 \quad (c)$$

Combining (a), (b) and (c) we get

$$\underline{R_3^2 = R_1^2 - X_1^2 - X_2^2 + (b_1 - X_1)^2}$$

TSS COMBINATION

Figure 4.8. Low-speed offtracking of tractor-semitrailer and TSS combinations.

To obtain a more generally descriptive term as an offtracking numeric, then, we shall work with the concept of "effective wheelbase" [5]. The effective wheelbase is independent of the turn radius and is defined as the wheelbase of a single-unit vehicle which produces the same amount of offtracking during a steady turn as the articulated vehicle under consideration. The effective wheelbase concept is very convenient when comparing vehicle configurations which differ in the number of articulation points and axle layouts. Taking the trajectory of the tractor fifth wheel as the reference radius, the effective wheelbase of the tractor-semitrailer and the tractor-semitrailer-semitrailer combinations are given by the expressions:

$$l_{eq})_{TS} = x_1 \quad (4.3)$$

$$l_{eq})_{TSS} = \sqrt{x_1^2 + x_2^2 - (b_1 - x_1)^2} \quad (4.4)$$

Equation (4.4) can be extended so as to be applicable for a vehicle with any number of trailers. The equivalent wheelbase of an articulated vehicle with n trailers is given by the expression:

$$l_{eq})_{n \text{ trailers}} = \sqrt{\sum_{i=1}^n x_i^2 - \sum_{i=1}^{n-1} (b_i - x_i)^2} \quad (4.5)$$

We shall now discuss the effect of multiple axles on: (1) offtracking and (2) the lateral force at the tractor fifth wheel for low-speed steady turns.

Influence of Multiple Axles

Tire sideslip angles cannot be assumed to be zero for a vehicle which is equipped with multiple trailer axles. During the low-speed steady turn, trailer tires operate at finite values of sideslip angle, and produce a net yawing moment which has to be counteracted by a lateral force at the tractor fifth wheel. Equations for the equivalent wheelbase and lateral fifth wheel force for a TSS combination equipped

with four axles on the first semitrailer and three axles on the second semitrailer will be derived here. A plan view of the vehicle is shown in Figure 4.9. The equations can be easily expanded to a vehicle with any number of trailing units and any number of axles on each trailer.

The following assumptions were made in the process of deriving the equations:

- 1) The sideslip angles at the tires are small so that the assumption $\tan \alpha = \alpha$ is valid.
- 2) The lateral forces generated at the tire-road interface are assumed to be linear functions of the sideslip angle at the tire, i.e., $F = -C \cdot \alpha$, where F is the cornering force, C is the cornering stiffness, and α is the slip angle.
- 3) The aligning moment generated at the tire-road interface is neglected.
- 4) The articulation angles are small such that the following approximations hold: $\sin \Gamma = \Gamma$ and $\cos \Gamma = 1.0$.
- 5) The track width of the vehicle is small compared to the radius of turn so that the sideslip angle is the same for all the tires on an axle.
- 6) The road surface is dry.

A double subscript notation is used for referencing the location and the slip angle at an axle. An axle with subscript ij denotes the j^{th} axle on the i^{th} trailer.

Referring to Figure 4.9, the slip angles at the trailer axles are given by the following equations.

$$\alpha_{11} = - \tan^{-1} \frac{(x_1 - a_1)}{R_2} \approx - \frac{(x_1 - a_1)}{R_2} \quad (4.6)$$

$$\alpha_{12} = \tan^{-1} \frac{(x_1 - a_1 - \delta_{11})}{R_2} \approx \frac{(x_1 - a_1 - \delta_{11})}{R_2} \quad (4.7)$$

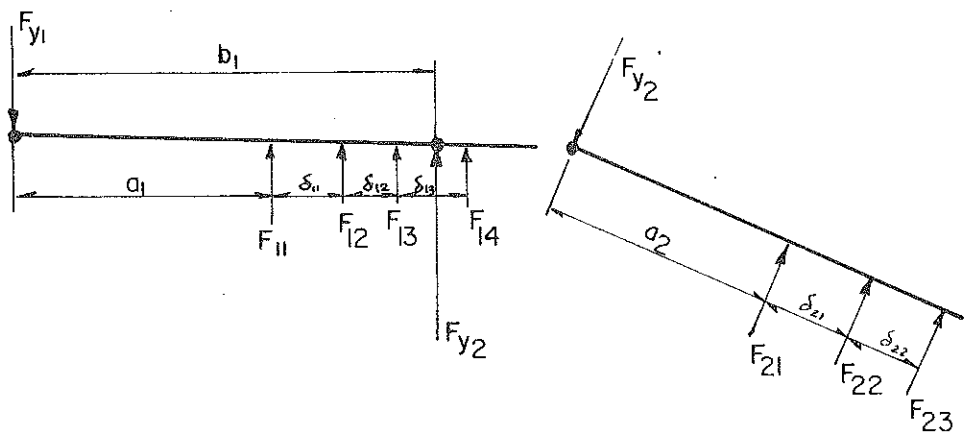
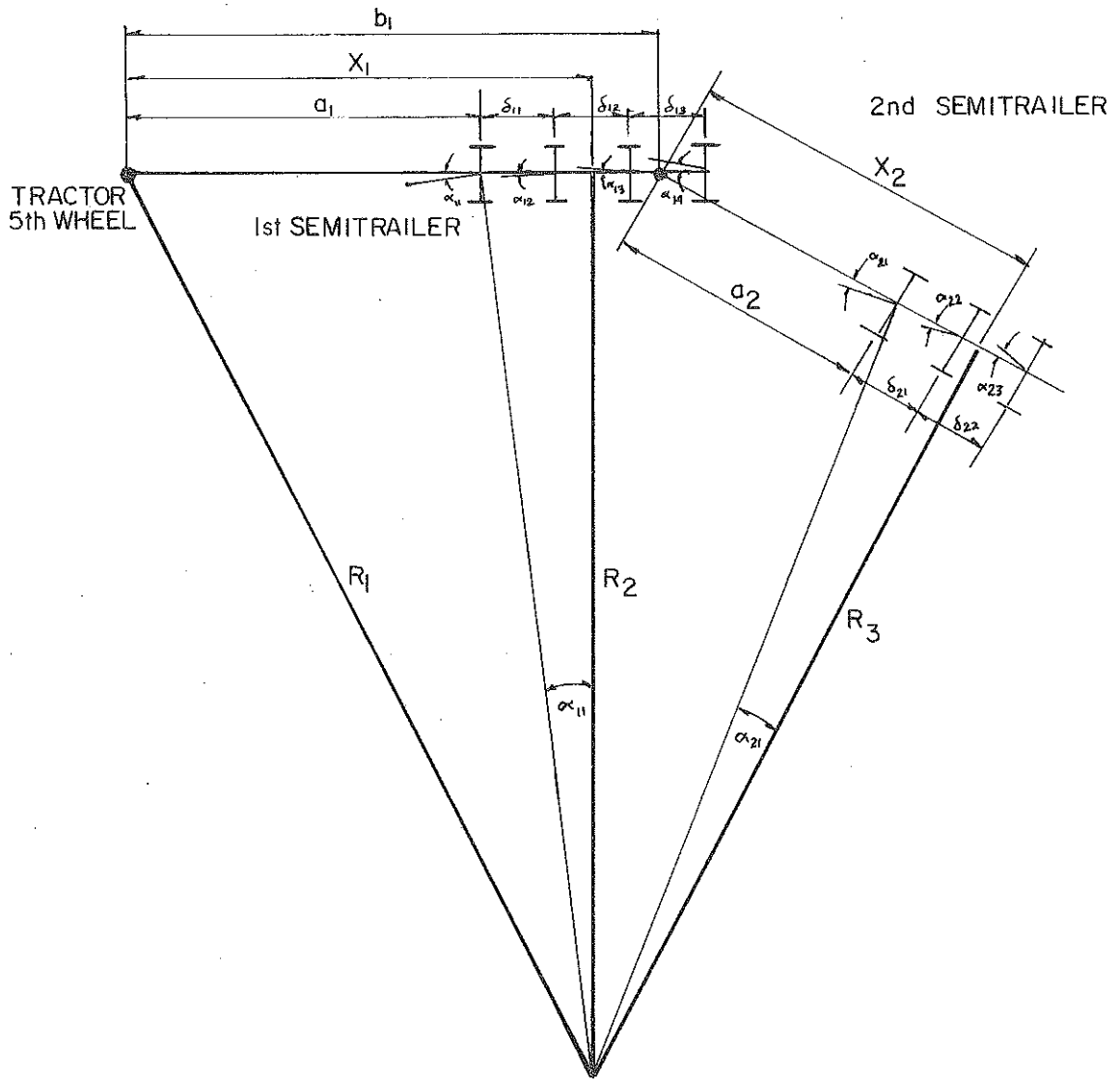

Figure 4.9. Tire slip angles and lateral tire forces for a multi-axle TSS combination.

$$\alpha_{13} = - \tan^{-1} \frac{(x_1 - a_1 - \delta_{11} - \delta_{12})}{R_2} \approx - \frac{(x_1 - a_1 - \delta_{11} - \delta_{12})}{R_2} \quad (4.8)$$

$$\alpha_{14} = - \tan^{-1} \frac{(x_1 - a_1 - \delta_{11} - \delta_{12} - \delta_{13})}{R_2} \approx - \frac{(x_1 - a_1 - \delta_{11} - \delta_{12} - \delta_{13})}{R_2} \quad (4.9)$$

$$\alpha_{21} = - \tan^{-1} \frac{(x_2 - a_2)}{R_3} \approx - \frac{(x_2 - a_2)}{R_3} \quad (4.10)$$

$$\alpha_{22} = - \tan^{-1} \frac{(x_2 - a_2 - \delta_{21})}{R_3} \approx - \frac{(x_2 - a_2 - \delta_{21})}{R_3} \quad (4.11)$$

$$\alpha_{23} = - \tan^{-1} \frac{(x_2 - a_2 - \delta_{21} - \delta_{22})}{R_3} \approx - \frac{(x_2 - a_2 - \delta_{21} - \delta_{22})}{R_3} \quad (4.12)$$

If the sum of the cornering stiffness of all the tires on axle ij is C_{ij} , the lateral force at axle ij is given by the equation

$$F_{ij} = - C_{ij} \alpha_{ij} \quad (4.13)$$

Taking the yaw moment equilibrium of the second trailer about its fifth wheel, we get:

$$F_{21} a_2 + F_{22} (a_2 + \delta_{21}) + F_{23} (a_2 + \delta_{21} + \delta_{22}) = 0 \quad (4.14)$$

Substituting for the lateral tire forces in (4.14), we get:

$$C_{21} \cdot \frac{(x_2 - a_2)}{R_3} a_2 + C_{22} \cdot \frac{(x_2 - a_2 - \delta_{21})}{R_3} (a_2 + \delta_{21}) + C_{23} \frac{(x_2 - a_2 - \delta_{21} - \delta_{22})}{R_3} (a_2 + \delta_{21} + \delta_{22}) = 0 \quad (4.15)$$

Upon solving for the wheelbase, x_2 , of the second semitrailer, we get:

$$x_2 = \frac{C_{21} \cdot a_2^2 + C_{22} (a_2 + \delta_{21})^2 + C_{23} (a_2 + \delta_{21} + \delta_{22})^2}{C_{21} a_2 + C_{22} (a_2 + \delta_{21}) + C_{23} (a_2 + \delta_{21} + \delta_{22})} \quad (4.16)$$

Moreover, the lateral force at the fifth wheel of the second semitrailer is:

$$F_{y_2} = F_{21} + F_{22} + F_{23}$$

$$F_{y_2} = C_{21} \frac{(x_2 - a_2)}{R_3} + C_{22} \frac{(x_2 - a_2 - \delta_{21})}{R_3} + C_{23} \frac{(x_2 - a_2 - \delta_{21} - \delta_{22})}{R_3} \quad (4.17)$$

We shall now solve for the wheelbase, x_1 , of the first semitrailer and the lateral force at the tractor fifth wheel. Proceeding along the same lines as Equations (4.14), (4.15), and (4.16), we find the wheelbase of the first semitrailer to be

$$x_1 = \frac{C_{11}a_1^2 + C_{12}(a_1 + \delta_{11})^2 + C_{13}(a_1 + \delta_{11} + \delta_{12})^2 + C_{14}(a_1 + \delta_{11} + \delta_{12} + \delta_{13})^2 - F_{y_2} b_1 R_2}{C_{11}a_1 + C_{12}(a_1 + \delta_{11}) + C_{13}(a_1 + \delta_{11} + \delta_{12}) + C_{14}(a_1 + \delta_{11} + \delta_{12} + \delta_{13})} \quad (4.18)$$

and the lateral force at the tractor's fifth wheel is given by the expression:

$$\begin{aligned} F_{y_1} &= F_{11} + F_{12} + F_{13} + F_{14} + F_{y_2} \\ &= C_{11} \frac{(x_1 - a_1)}{R_2} + C_{12} \frac{(x_1 - a_1 - \delta_{11})}{R_2} + C_{13} \frac{(x_1 - a_1 - \delta_{11} - \delta_{12})}{R_2} \\ &\quad + C_{14} \frac{(x_1 - a_1 - \delta_{11} - \delta_{12} - \delta_{13})}{R_2} + C_{21} \frac{(x_2 - a_2)}{R_3} + C_{23} \frac{(x_2 - a_2 - \delta_{21})}{R_3} \\ &\quad + C_{23} \frac{(x_2 - a_2 - \delta_{21} - \delta_{22})}{R_3} \end{aligned} \quad (4.19)$$

The equivalent wheelbase of the multi-axle tractor-semitrailer-semitrailer combination can be obtained by substituting the expressions (4.16) and (4.18) (for the wheelbases x_1 and x_2) in Equation (4.4). The effective wheelbase calculations for vehicle combinations which differ from the one considered here can be performed by suitably modifying Equations (4.16) and (4.18).

Equation (4.19) indicates that the lateral fifth wheel force is inversely related to the radius of the turn. Because of the small angle assumption involved in deriving the above equations, the analysis is not

valid for turns of very small radius during which the tire slip angles are large. At the large slip angles which are encountered in small radius turns, the lateral forces generated at the tire-road interface tend to saturate and depart considerably from the linear sideslip angle-lateral force relationship that was assumed in deriving the equation. For turns which are 100 feet in radius and above, the lateral fifth wheel force predictions based on Equation (4.19) will be fairly accurate.

Results

Low-Speed Offtracking. The calculated values for the effective wheelbase of the candidate vehicle configurations are plotted in Figure 4.10. The figure portrays the effective wheelbase as a function of the payload volume of the vehicles. For the sake of comparison, we have also plotted the effective wheelbases of the 8800-gallon capacity tractor-semitrailer which meets the MC306 specifications, and a 55-foot Michigan double tanker in the conventional (dolly and pintle hook) arrangement and the modified (rigidized pintle hook) arrangement. The effective wheelbases of the tractor-semitrailer configurations are shown in each of two conditions, namely, (1) with all of the semitrailer axles on the ground and (2) with the foremost semitrailer axle (which is presumed to be liftable) in the raised position.

The following observations can be made from the results of the offtracking calculations:

1. None of the candidate vehicles are seen to exhibit effective wheelbase lengths which are larger than that of the reference MC306 tanker. Therefore, from the point of view of slow-speed offtracking, all of the candidate vehicles are at least as good or better than the typical MC306 gasoline tankers.
2. The effective wheelbases of the 65-foot TSS combinations are not significantly smaller than those of the tractor-semitrailer combination. Therefore, if low-speed offtracking qualities were to be improved beyond those attained by the candidate tractor-semitrailers, TSS

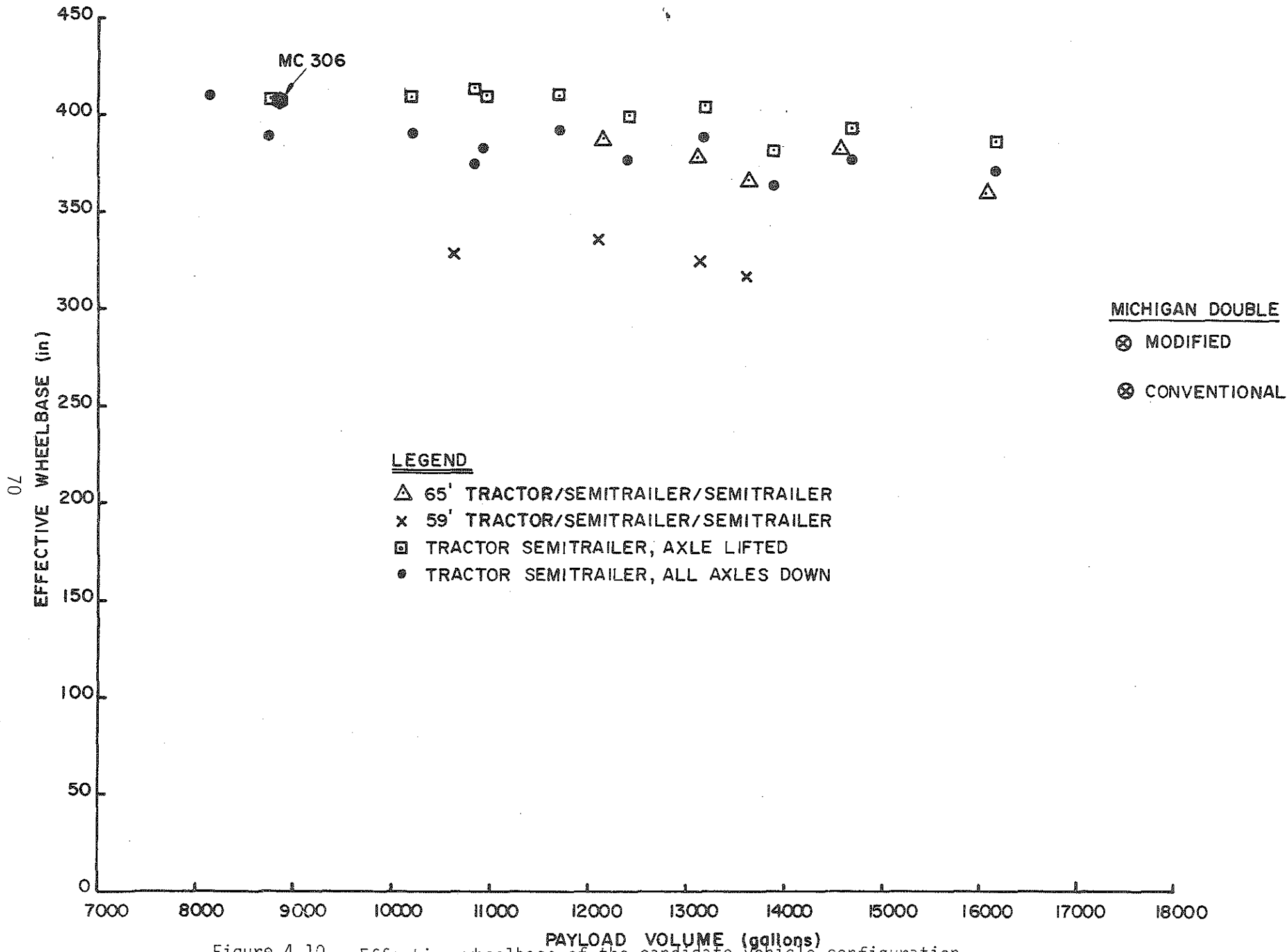

Figure 4.10. Effective wheelbase of the candidate vehicle configuration

combinations would only become attractive at overall lengths shorter than 65 feet.

3. None of the candidate vehicles have offtracking qualities which are comparable to those of the 55-foot Michigan double tanker.

Lateral Fifth Wheel Force. A semitrailer having multiple axles will only proceed in a curved path if a side force is produced by the tractor tires and reacted through the fifth wheel coupling. Since this force tends to produce a yaw instability leading toward jackknife of the tractor, the lateral fifth wheel force can be looked upon as a measure of a non-quality, a degrading characteristic which is worse with trailers having more fixed axles in a row. The lateral fifth wheel force which is needed to negotiate a turn is dependent on the turn radius. Values of fifth wheel force for comparing all of the candidate vehicles were calculated using a constant turn radius of 400 feet. The lateral fifth wheel force requirement for the candidate vehicle configurations is plotted in Figure 4.11 with the payload volume as the abscissa and the lateral fifth wheel force as the ordinate. The lateral force levels for the reference 8800-gallon MC306 tractor-semi-trailer and the 55-foot Michigan double-bottom tanker are also shown in the figure.

The lateral force requirement for the tractor-semi-trailer combination is shown again for two operating conditions: (1) with all of the axles in contact with the road surface and (2) with the foremost semi-trailer axle in the raised position. The lateral fifth wheel force requirement for the tractor-semi-trailer combinations can be seen to be very sensitive to axle number accompanying payload volume. For example, by increasing the payload capacity from that of the largest recommended vehicle, the 13,200-gallon configuration (with six semi-trailer axles), to a capacity of 16,150 gallons (having eight semi-trailer axles), the lateral fifth wheel force shows an increase of almost 250 percent.

When the semi-trailers that are designed with no spread axles are operated with one front axle in the raised position, the lateral fifth wheel force is seen to be reduced by 40 to 50 percent. The reduction is

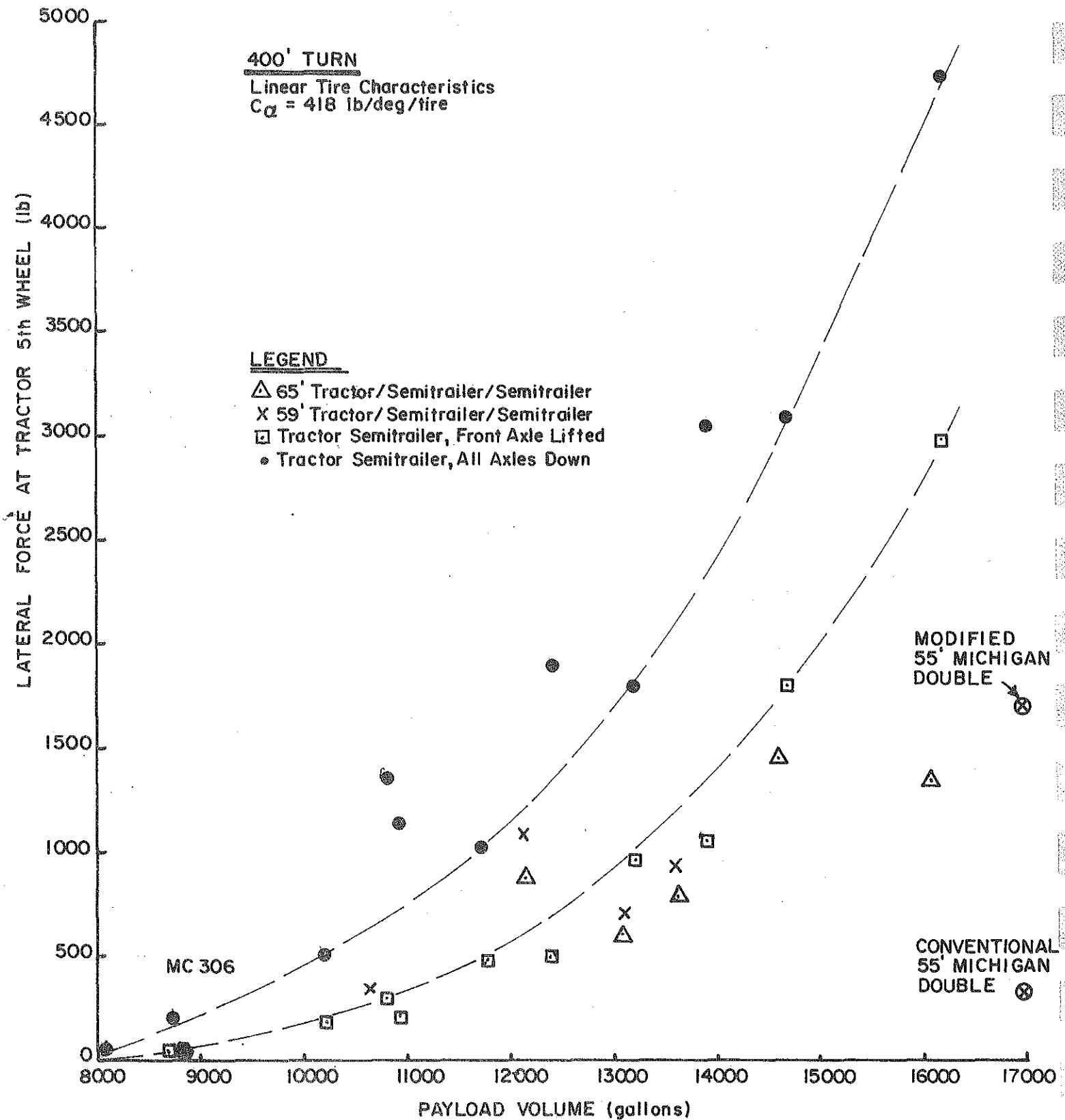

Figure 4.11. Lateral fifth wheel force requirements for the candidate vehicle configurations.

seen to be even greater for the semitrailer configurations equipped with a spread axle (#2b, #3b, #4b, and #5b).

For capacities below 15,000 gallons, the TSS combinations exhibit lateral fifth wheel force requirements that are only slightly lower than those of the tractor-semitrailer combinations which are operated with their foremost trailer axles in the raised position. However, for the largest capacity, eleven-axle vehicle, the 65-foot TSS combination needs a lateral force which is only 45 percent of that of the corresponding tractor-semitrailer combination with its front axle in the lifted position.

4.1.3 Steady Turning Rollover Thresholds of Candidate Vehicles.

The steady turning rollover threshold of a vehicle plays an important role in determining the likelihood that either maneuvering- or accident-induced forces can cause the vehicle to roll over. Analysis of the BMCS accident data file has clearly shown the close correlation between the steady turning rollover threshold of a vehicle and its rollover involvement. In this section, we shall first describe a roll plane model which was used for calculating the steady turning rollover thresholds of the candidate vehicles. Next, the computed value of the rollover thresholds for the candidate tractor-semitrailer and TSS combination will be presented.

Static Roll Model

The static roll model was developed for the purpose of estimating the rollover thresholds of the candidate vehicle configurations. Results of earlier investigations by Isermann [6] and Gillespie, et al. [7] served as a basis for the development of the static roll model. The formulating equations, as well as a computer program useful for estimating rollover thresholds, is presented in Appendix B. The discussion in this section is therefore restricted to a description of the essential features of the model.

Features of the model and the assumptions made in the process of deriving the underlying equations are listed below.

1. The vehicle is assumed to be effectively rigid in torsion. The structural compliance of the tractor and trailer sprung masses are therefore neglected and the sprung masses are lumped together and represented by a single sprung mass in the roll plane.
2. In order to simplify the calculations, axles with similar suspension properties are grouped together such that a tractor-semitrailer is represented by a set of three composite axles. Figure 4.12 shows the side view of an example tractor-semitrailer, as represented in the roll model. The composite axles are:
 - a) tractor front axle,
 - b) tractor rear axles (either a single axle or a tandem) combined and represented by one axle, and
 - c) all trailer axles, combined and represented as one axle.
3. The articulation angles are small so that the effect of articulation angle on the rollover threshold can be neglected.
4. Figure 4.13 shows the representation of axles and suspensions in the roll plane model. The relative roll motion between the sprung mass and the axles is assumed to take place about roll centers which are at fixed distances beneath the sprung mass. The suspension springs are assumed to remain parallel to the \vec{k}_{u_i} axes of the axles and transmit only compressive or tensile forces.

The roll centers are permitted to slide freely (with respect to the axles) along the \vec{k}_{u_i} axes. All axle forces which act in a direction parallel to the \vec{k}_{u_i} are taken up by the suspension springs, while all axle forces along the \vec{j}_{u_i} axes are assumed to act through the roll center, R_i .

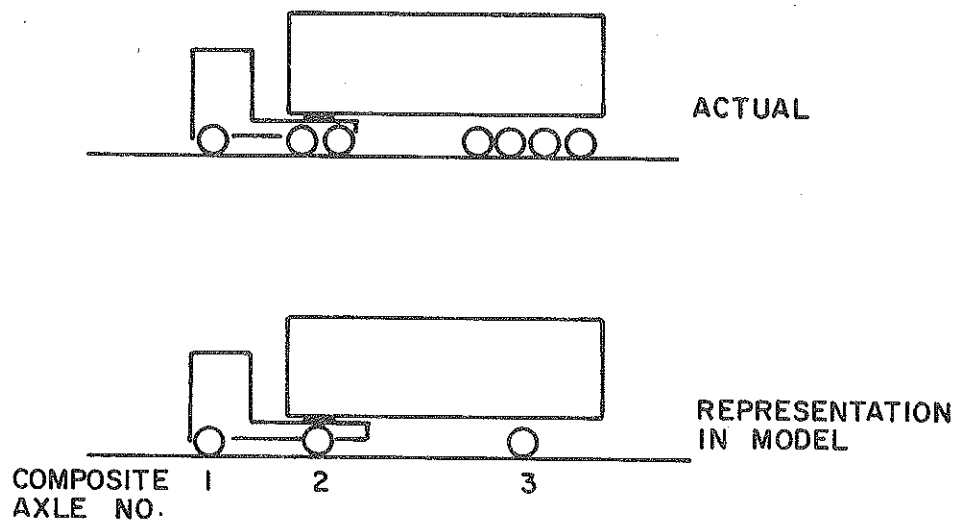

Figure 4.12. Representation of the axles of a tractor-semitrailer in the static roll plane model.

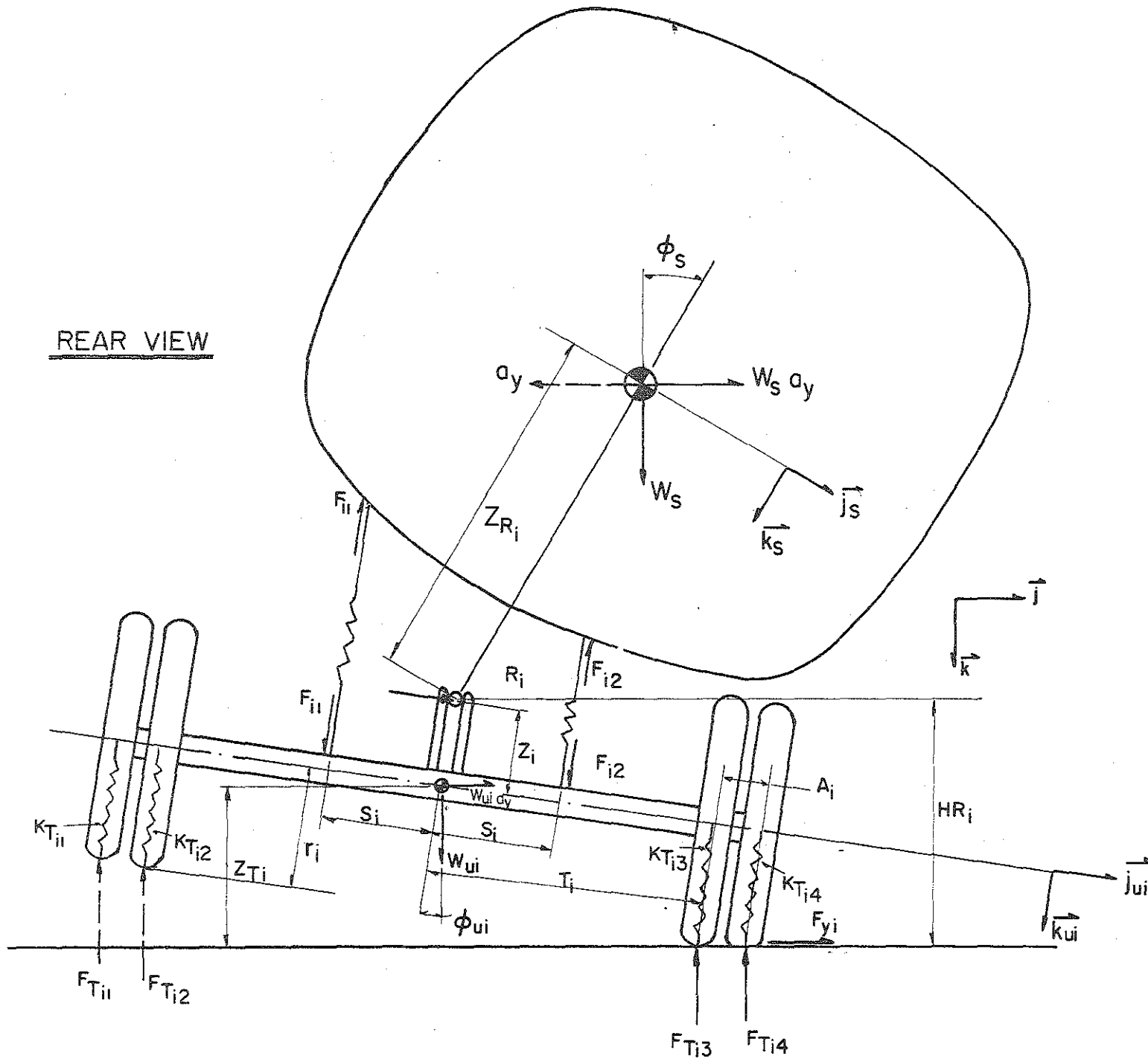

Figure 4.13. Representation of the axles and suspensions in the static roll plane model.

5. Suspension nonlinearities such as backlash and progressively hardening suspension springs are represented by a tabular load-deflection input format. The suspension forces and the spring rates at any given deflection are then compared by linear interpolation. Figure 4.14 shows the representation of a suspension spring in the roll model.
6. The total vertical load carried by each composite axle is assumed to remain constant during the rollover process. In order to accommodate any pitching motion that might take place during rollover, the sprung mass is permitted to take up different vertical deflections at each of the three axle locations.
7. The vertical load carried by the tires is assumed to act through the midpoint of the tread width. As shown in Figure 4.15, the effect of camber angle and the effect of the lateral compliance of the tire tend to have opposing effects on the lateral translation of the centroid of the normal pressure distribution at the tire-road interface. Both of these effects are small and tend to cancel out. In order to keep the analysis simple, the lateral translation of the normal load is neglected.
8. The roll angles of the sprung mass and the axles are small, such that the small angle assumptions $\sin(\phi) = \phi$ and $\cos(\phi) = 1.0$ hold.

Accuracy of Rollover Threshold Estimates

The rollover threshold values calculated using the static roll model were found to compare well with measurements made by Isermann [6] in Germany. Isermann measured the rollover thresholds of tank vehicles using a tilt-table arrangement. The rollover thresholds estimated using the static roll model and the measurements made by Isermann using the tilt-table arrangement are compared in Table 4.3 for four

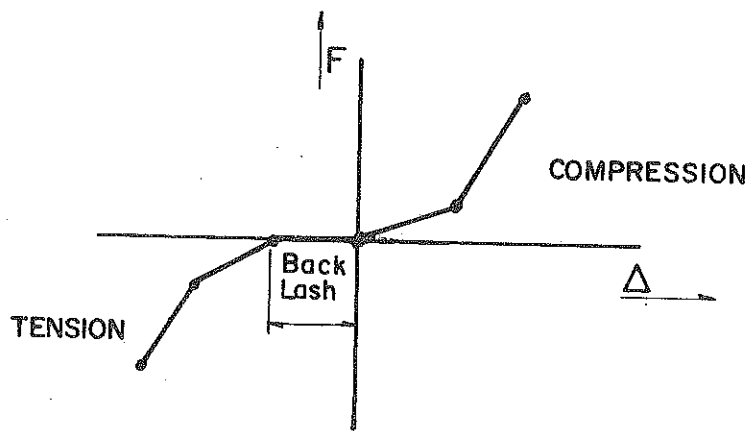

Figure 4.14. Representation of suspension spring characteristics in the roll plane model.

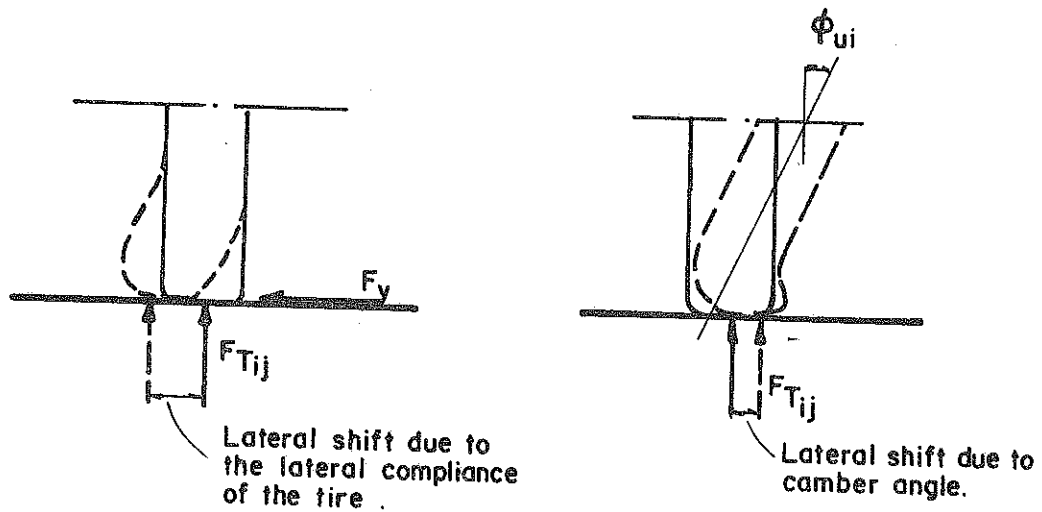

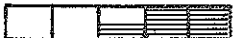



Figure 4.15. The effect of lateral compliance and camber angle on the centroid of the normal pressure distribution at the tire/road interface.

Table 4.3. Comparison of Rollover Threshold Estimates with Tilt-Table Measurements Made By Isermann [6].

Rollover Threshold (g's)				
Isermann Calculation	Tilt-Table Measurement*	Estimates Using Static Roll Model***	% Error	Loading Condition
0.733	---**	0.747	+ 1.9	
0.333	0.344	0.337	- 2.0	
0.464	0.487	0.492	+ 1.0	
0.322	0.344	0.342	- 0.5	

*For Configuration #1 in Reference [6].

**The tilt-table arrangement was not capable of measuring rollover thresholds which were higher than 0.62 g.

***The c.g. height and suspension properties which are needed for computing the rollover threshold were obtained from Reference [6].

different loading conditions of a tank vehicle. Rollover threshold levels calculated by Isermann are also shown in the table. The results indicate that the static roll model can predict rollover thresholds to within 2 percent of the reported tilt-table measurements.

Rollover Thresholds of Candidate Vehicles

The rollover thresholds of the candidate vehicles are plotted as a function of payload capacity in Figure 4.16. The rollover threshold values pertain to 96-inch-wide tractors coupled to 102-inch-wide trailers. The vehicles are assumed to be in the fully loaded condition. The parameters needed to describe the candidate vehicles, in the roll plane model, are listed in Appendix B. We shall discuss the rollover thresholds of the tractor-semitrailer first, following which the rollover thresholds of the TSS combination will be discussed.

Tractor-Semitrailers. Figure 4.16 indicates that vehicles having an increased capacity do not show significantly reduced levels of rollover threshold. For example, a 100-percent increase in the payload capacity—from 8,000 to 16,000 gallons—results in a decrease of only 11 percent in the rollover threshold. The rollover thresholds of the tractor-semitrailers designed with 18,000-lb capacity spread axles (such as #2b, #3b, #4b, and #5b) can be seen to fall below the pattern followed by the rest of the tractor-semitrailer combinations.

When the payload capacity is increased, two counteracting effects come into play, namely:

- 1) an increase in payload capacity raises the c.g. height of the vehicle and hence lowers the rollover threshold, and
- 2) when the payload capacity is increased, the number of 102-inch-wide semitrailer axles are increased.

The larger number of 102-inch-wide trailer axles (which are capable of generating higher roll resisting moments due to their larger track width) tends to raise the rollover threshold of the vehicles with higher payload capacities.

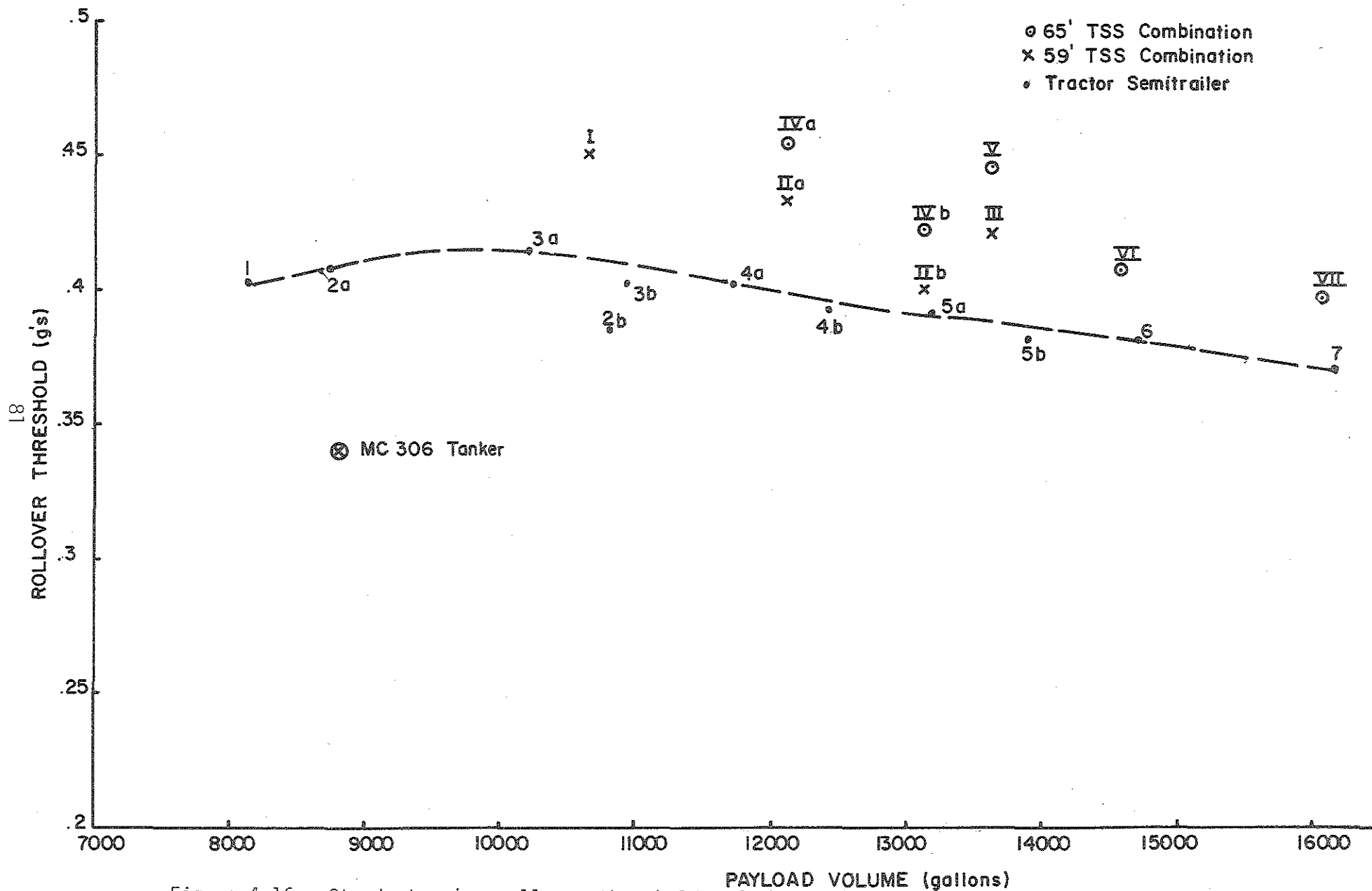

Figure 4.16. Steady turning rollover thresholds of the candidate vehicle configurations.

For increasing level of payload up to a capacity of 10,000 gallons, the latter effect, Number 2 above, tends to dominate and thus results in a small improvement in rollover threshold. For increases in payload beyond 10,000 gallons, the first effect becomes more prominent and produces a gradual decrease in the rollover threshold.

TSS Combinations. Both the 59-foot and the 65-foot TSS combinations are seen to exhibit higher rollover thresholds than the corresponding tractor-semitrailers of the same payload capacity. The increased length of these vehicles permits them to achieve lower c.g. heights and hence higher rollover thresholds than the tractor-semitrailers.

As was stated earlier in Section 4.1.1, it is pertinent to note that not all of the TSS combinations were designed to carry the same load at the tractor fifth wheel. Configurations IIb, IVb, VI, and VII carry a fifth wheel load of only 24,000 lbs. The vehicles which carry the lower fifth wheel loads can be seen to exhibit higher rollover thresholds than the rest of the TSS combinations. This is due to the fact that the vehicles which carry a smaller load at the tractor fifth wheel are less dependent on the 96-inch-wide tractor axles to provide the roll-restoring moment, and hence are capable of achieving higher rollover thresholds.

The rollover threshold values will be used in conjunction with the rollover threshold/rollover involvement relationship (which was generated using the BMCS data) to determine the rollover risk posed by each of these vehicle designs. The rollover risk calculations are given in Section 6.0.

4.1.4 Linear Yaw Plane Analysis. A broad understanding of the directional qualities of articulated vehicles can be gained by conducting a linear analysis of their yaw plane response characteristics. A study of the amplified (or attenuated) directional response exhibited by the trailers of an articulated combination can be very useful in gaining an insight into the dynamic rollover immunity of such vehicles. A yaw plane analysis is therefore included here to serve as the basis for conducting the more elaborate simulation of the combined directional and roll behavior of the candidate vehicle configurations.

Several techniques are available for studying the vehicle response in the linear regime, namely:

- 1) eigenvalue analysis,
- 2) transient response analysis, and
- 3) frequency response analysis.

Frequency response analysis was applied in this study as the most generally useful technique for studying the response of the tractor-semitrailers and TSS combinations. A frequency response analysis provides information on the amplification (or attenuation) and the phasing of the trailer motions over any given range of steering input frequencies. A linear yaw plane model which was developed by HSRI as part of an earlier study on double tankers [2] was used for conducting the frequency response calculations.

The amplitude and phase angle of the lateral acceleration response of a tractor-semitrailer and a 59-foot TSS combination are shown in Figures 4.17 and 4.18, respectively. The vehicles are assumed to be traveling at a forward speed of 50 mph in the fully loaded condition. In these figures, the magnitude of the lateral acceleration gain (ft/sec² per degree of front-wheel angle displacement) is plotted in the decibel scale [Note: a quantity, x , when expressed in the decibel scale is $20 \log_{10}(x)$] and the steering input frequency is in the units of (rad/sec).

With reference to Figure 4.17, it can be observed that the lateral acceleration response of semitrailers does not exhibit any amplification (with respect to the tractor lateral acceleration) over the entire range of 0.1 to 100 rad/sec of steering input frequencies. For steering input frequencies below 1 rad/sec, the difference between the tractor and the semitrailer lateral accelerations tends to be small and the magnitude reaches the levels of lateral acceleration gain present in steady turning. At a higher input frequency, such as a 1/2 Hz (3.14 rad/sec) for example, the response of the semitrailer lateral acceleration becomes attenuated by -2.75 db (i.e., semitrailer lateral acceleration is $10^{-2.75/20} = 0.73$ times the tractor lateral acceleration magnitude) and lags the lateral acceleration response of the tractor by

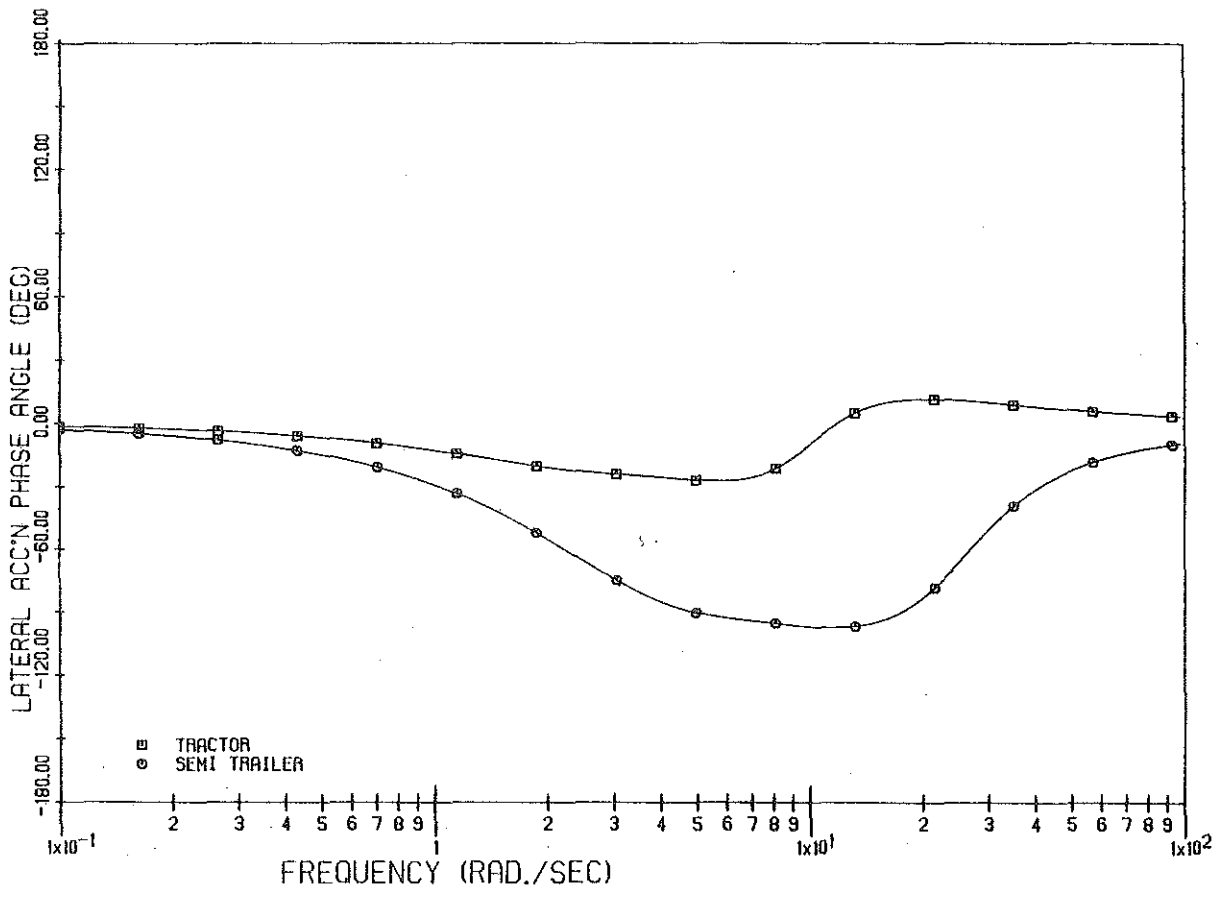

TRACTOR SEMITRAILER, CONFIG #1, FREQ RESPONSE

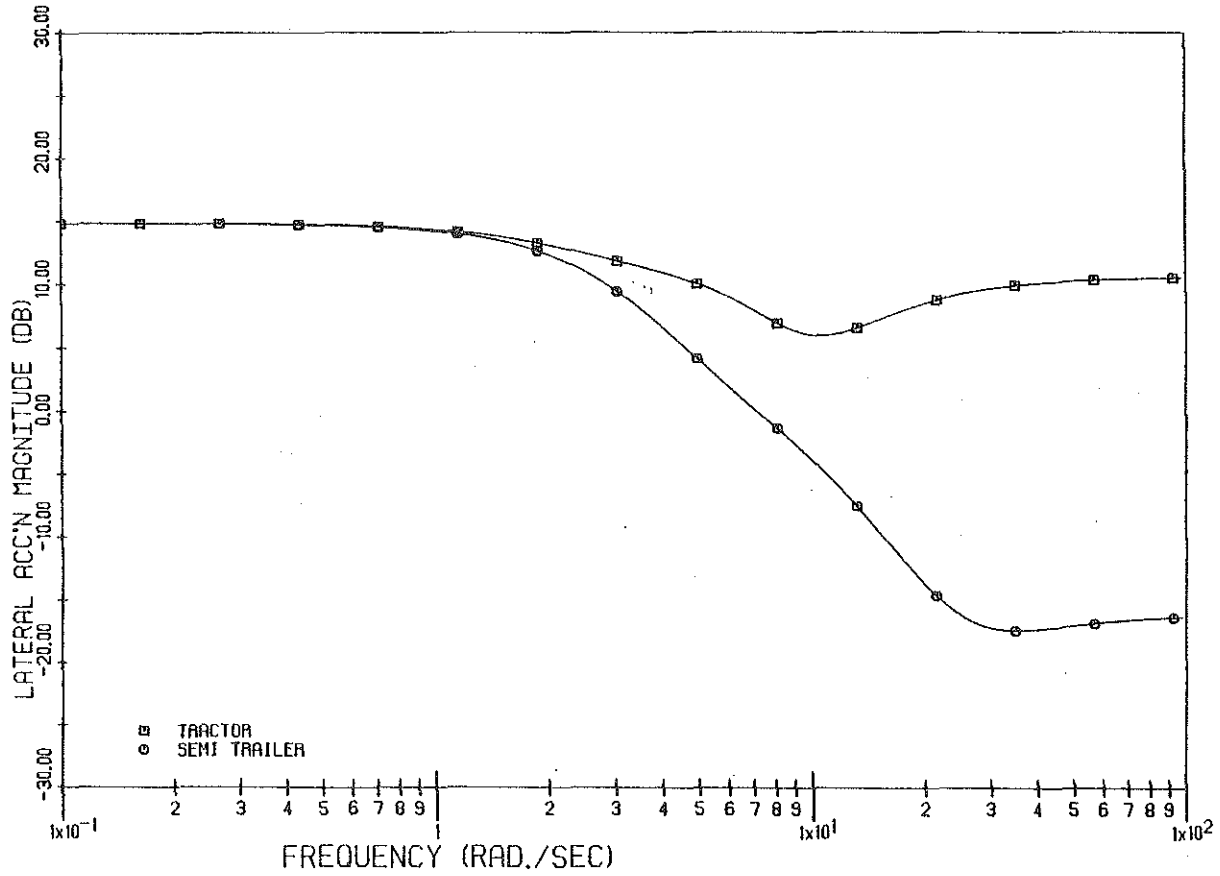

TRACTOR SEMITRAILER, CONFIG #1, FREQ RESPONSE.

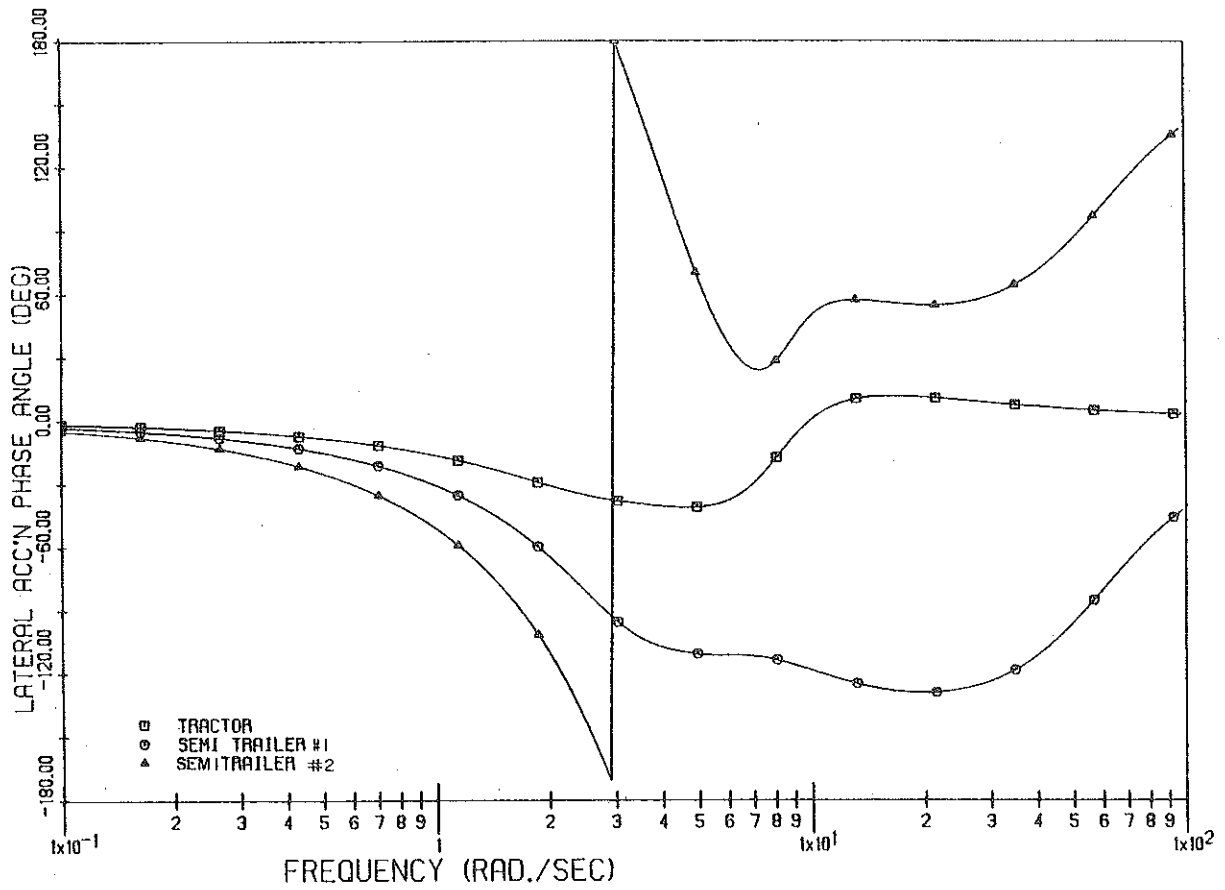

59' TSS COMBINATION CONFIG. #1 FREQ RESPONSE,

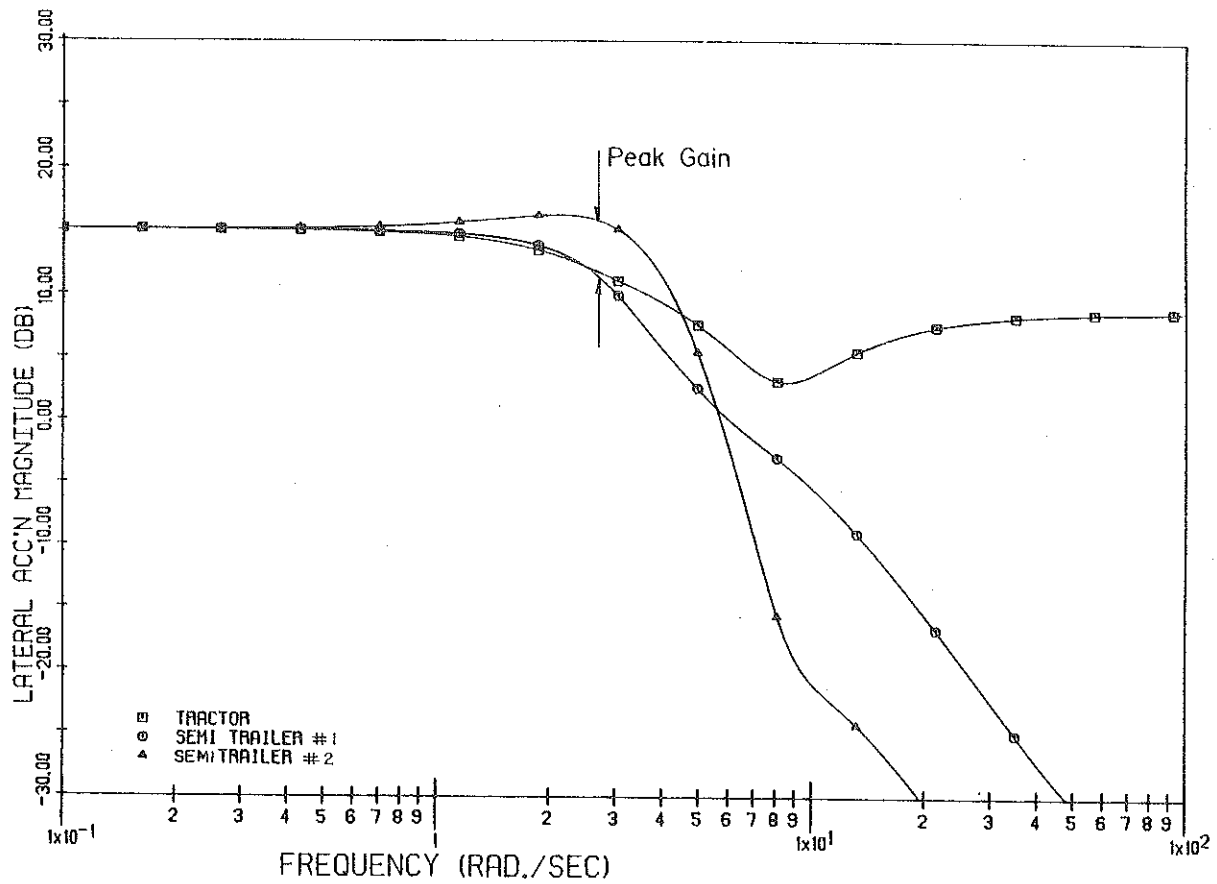

59' TSS COMBINATION, CONFIG. # I FREQ RESPONSE.

Figure 4.18

a phase angle of 51 degrees. Further increases in the steering input frequency result in larger attenuation of the semitrailer lateral acceleration. All of the candidate tractor-semitrailer configurations exhibited frequency response characteristics which were very similar to the one shown in Figure 4.17.

Figure 4.18 indicates that the second semitrailer of the TSS combination exhibits an amplification in the lateral acceleration response for steering input frequencies which are in the range of 1 to 4 rad/sec. At a steer input frequency of 1/2 Hz (3.14 rad/sec), for example, the lateral acceleration of the second semitrailer is amplified by 3.75 db (or 1.54 times the tractor lateral acceleration amplitude) and is almost completely out of phase with the lateral acceleration response of the tractor. The maximum gain exhibited by the second semitrailer (in the frequency domain) serves as a useful measure of the amplified response that would be exhibited during transient maneuvers. The peak gains of the pup lateral accelerations for all of the 59-foot and 65-foot TSS combinations are shown in Figure 4.19 in a bar-chart format. The 65-foot TSS combinations are seen to exhibit lower levels of amplification than the 59-foot doubles. Except for configurations #III and #IVb, the amplification levels of the rest of the vehicles are found to lie within a relatively narrow range of 1.27 to 1.43. In the case of vehicles #III and #IVb, the short wheelbases of the second semitrailers, along with a rearward weight bias of the trailers, results in higher levels of amplification.

If the second semitrailer of each of the TSS combinations were permitted to roll independently of the rest of the vehicle, the highly amplified lateral acceleration behavior would imply that rollover of the second semitrailer would occur in transient maneuvers for which the tractor might experience only relatively low levels of lateral acceleration. Such an anomalous behavior could not occur with TSS combinations being considered here, however, since the second semitrailer is connected to the first semitrailer by means of a fifth wheel type coupling which is rigid in roll. The following discussion clarifies the roll moment interaction which takes place between the tractor and the trailers of tractor-semitrailers and TSS combinations during dynamic maneuvers.

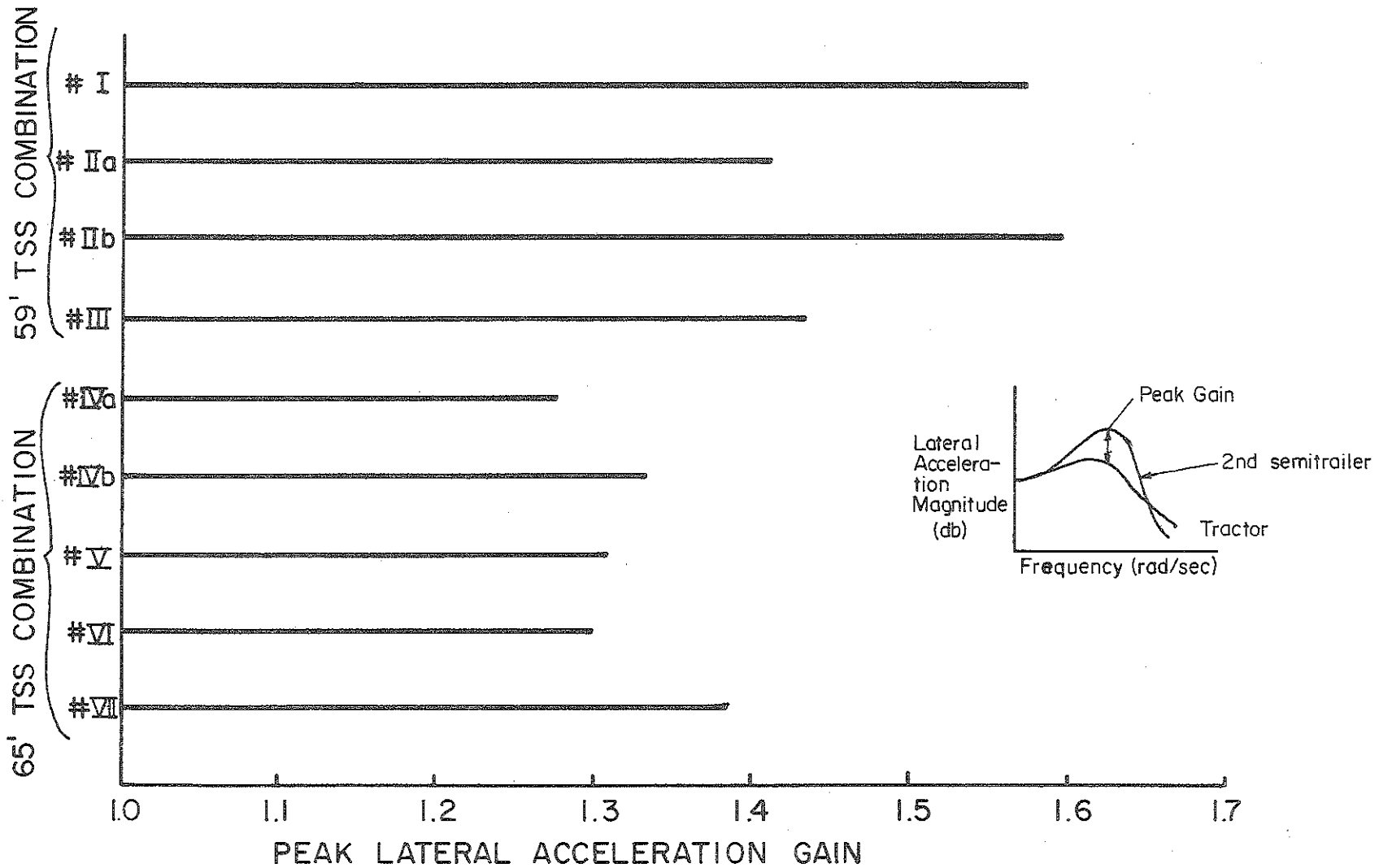

Figure 4.19. Lateral acceleration gains of the candidate TSS configurations.

Roll Implications of Directional Response Characteristics

In the case of tractor-semitrailers and TSS combinations, the tractor and the trailers are rigidly coupled in roll by fifth wheel type couplings. Hence, the entire vehicle is effectively constrained to overturn as a single unit. The magnitude of the total overturning moment acting on the vehicle is therefore the factor which determines whether or not the vehicle will roll over.

The relationship between the overturning moment and the lateral acceleration level, a_y , is illustrated in Figure 4.20 for a vehicle which is represented by a single mass, m , which is placed at a height, h , above the ground level. For small roll angles, the roll moment is given by the following simplified expression:

$$\text{roll moment} = m \cdot a_y \cdot h \quad (4.20)$$

If, during a transient maneuver, the instantaneous lateral accelerations at the tractor, semitrailer, and the second semitrailer of a TSS combination are a_{y_1} , a_{y_2} , and a_{y_3} , respectively, the total overturning moment acting on the vehicle can be shown to be:

$$\text{Roll moment})_t = m_1 a_{y_1} h_1 + m_2 a_{y_2} h_2 + m_3 a_{y_3} h_3 \quad (4.21)$$

[Note: The articulation angles and roll angle are assumed to be small.]

Since the tractor and the trailers are rigidly connected in roll, the roll plane motion of the vehicle can be visualized to be that of a single-unit vehicle of mass, m_{eq} , and c.g. height, h_{eq} , where

$$m_{eq} = (m_1 + m_2 + m_3) \quad (4.22)$$

$$\text{and } h_{eq} = \frac{(m_1 h_1 + m_2 h_2 + m_3 h_3)}{(m_1 + m_2 + m_3)} \quad (4.23)$$

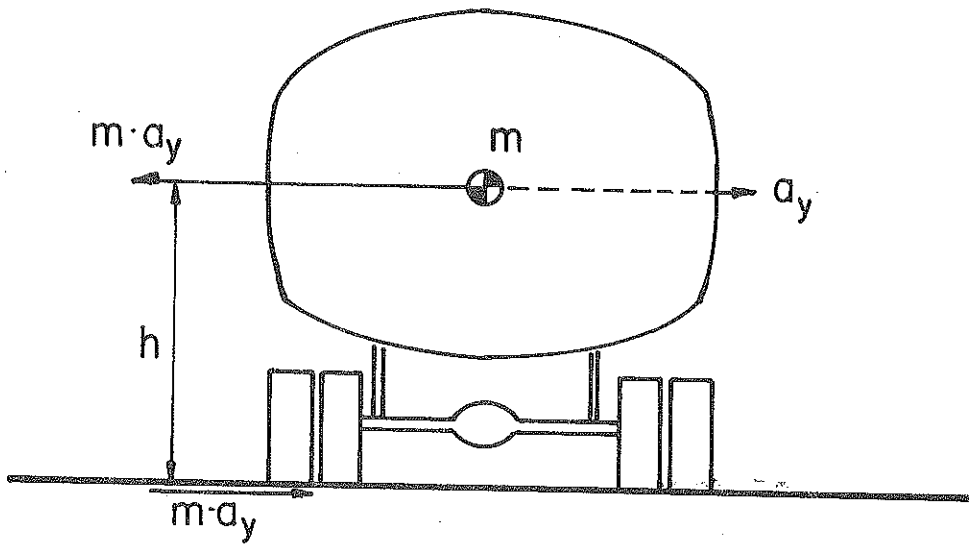

Figure 4.20. Relationship between overturning moment and lateral acceleration level, a_y .

The lateral acceleration components, a_{y_1} , a_{y_2} , and a_{y_3} , can therefore be replaced by an equivalent or average lateral acceleration which acts on the equivalent single-unit vehicle; i.e.,

$$m_{eq} h_{eq} a_{y_{eq}} = m_1 h_1 a_{y_1} + m_2 h_2 a_{y_2} + m_3 h_3 a_{y_3} \quad (4.24)$$

$$\begin{aligned} a_{y_{eq}} &= \frac{m_1 h_1 a_{y_1} + m_2 h_2 a_{y_2} + m_3 h_3 a_{y_3}}{(m_1 h_1 + m_2 h_2 + m_3 h_3)} \\ &= \frac{m_1 h_1 a_{y_1}}{(m_1 h_1 + m_2 h_2 + m_3 h_3)} + \frac{m_2 h_2 a_{y_2}}{(m_1 h_1 + m_2 h_2 + m_3 h_3)} + \frac{m_3 h_3 a_{y_3}}{(m_1 h_1 + m_2 h_2 + m_3 h_3)} \end{aligned} \quad (4.25)$$

Equation (4.25) gives the weighting factors that need to be applied (or the importance to be attached) to the instantaneous lateral acceleration levels of each of the articulated units. If, during transient maneuvers, the average lateral acceleration of a vehicle exceeds the lateral acceleration of the tractor, it is an indication that the vehicle would exhibit poorer dynamic rollover immunity than a single-unit vehicle which has the same steady turning rollover threshold.

The above discussion can be extended to the frequency domain as well. In the frequency domain the lateral accelerations of the tractor and the trailer are vector quantities which possess both magnitude and phase. Therefore, the magnitude and phase angle of the average lateral acceleration response can be obtained through vector addition of the tractor and trailer lateral acceleration responses.

$$\begin{aligned} \vec{a}_{y_{average}} &= \frac{m_1 h_1 \vec{a}_{y_1}}{(m_1 h_1 + m_2 h_2 + m_3 h_3)} + \frac{m_2 h_2 \vec{a}_{y_2}}{(m_1 h_1 + m_2 h_2 + m_3 h_3)} \\ &\quad + \frac{m_3 h_3 \vec{a}_{y_3}}{(m_1 h_1 + m_2 h_2 + m_3 h_3)} \end{aligned} \quad (4.26)$$

The magnitude and phase angle of the average lateral acceleration are shown in Figure 4.21 for a TSS combination. On comparing Figure 4.21 with Figure 4.18, it is important to note that the peak gain of

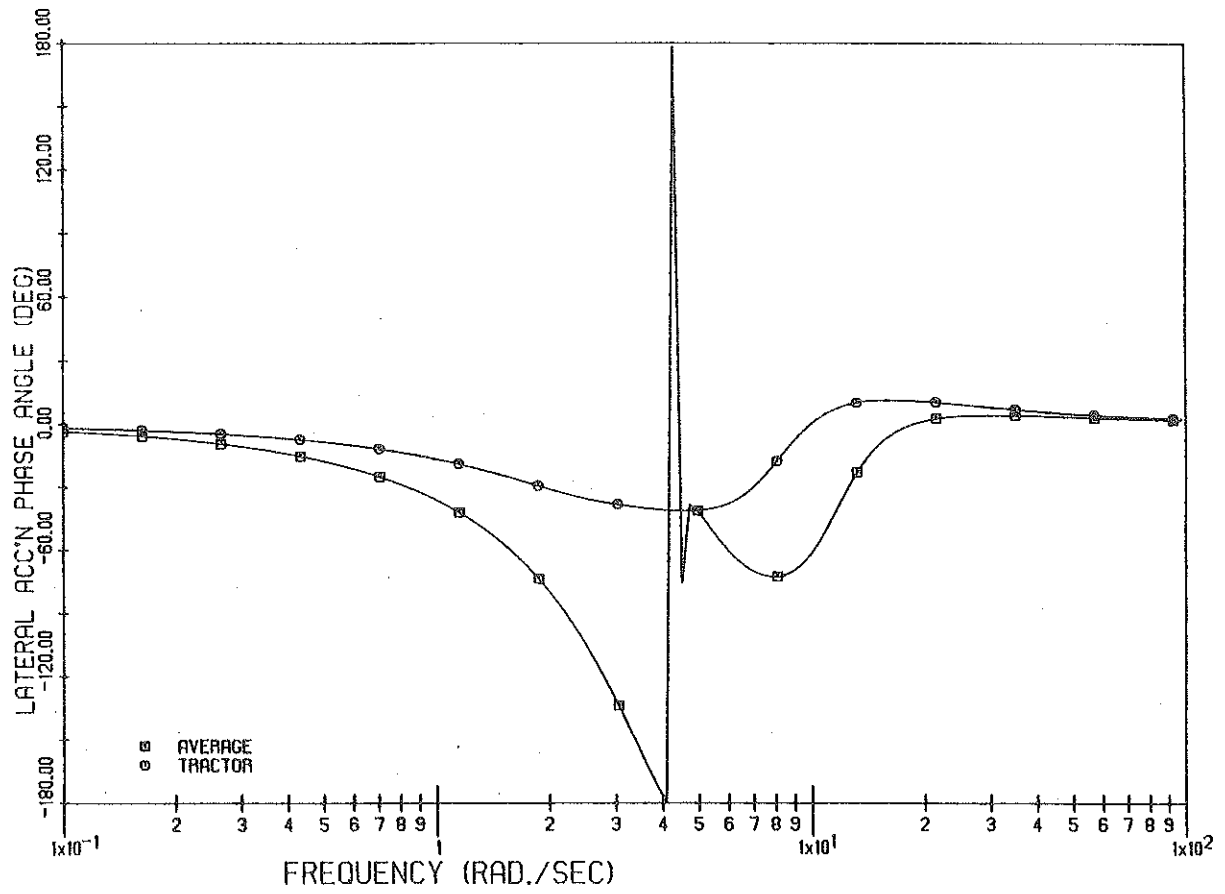

59' TSS COMBINATION, CONFIG #1 FREQ RESPONSE. JULY 22 '80

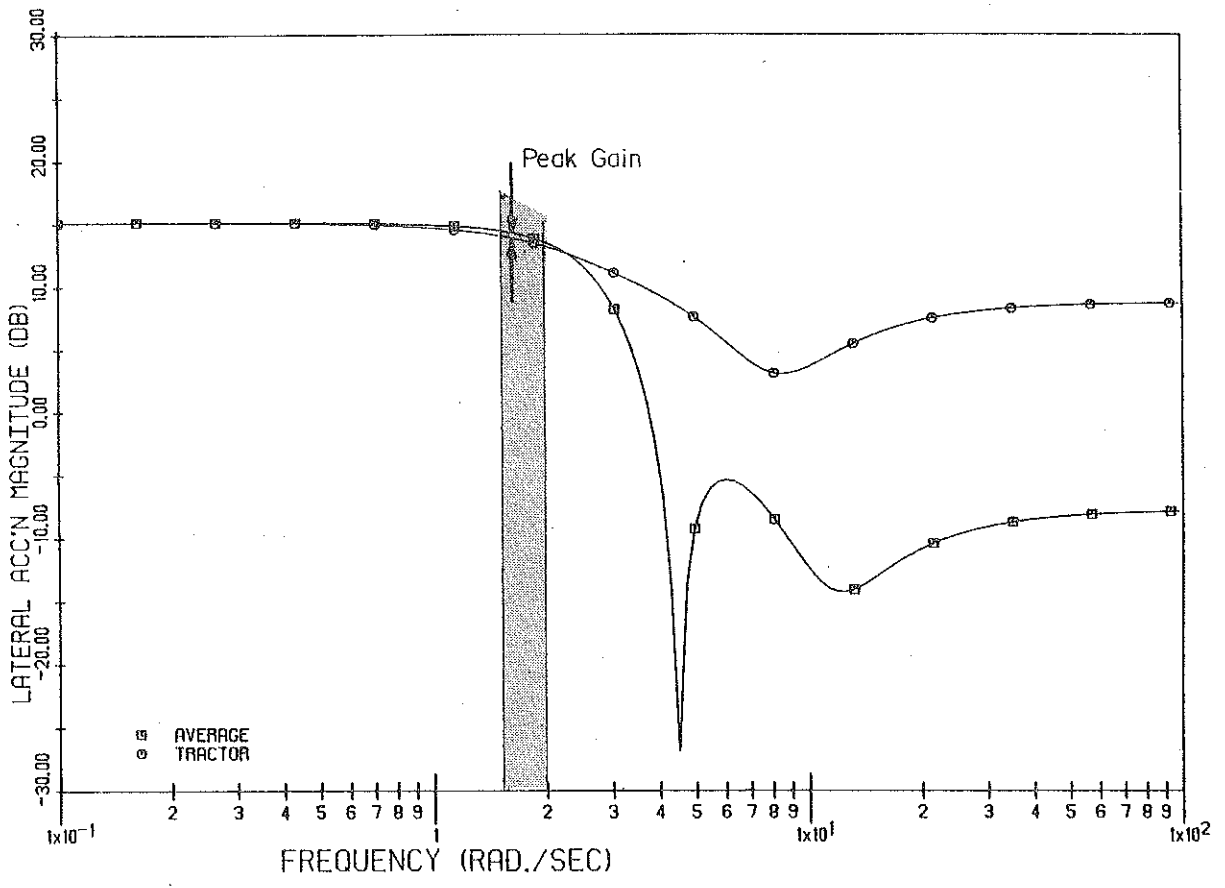

59' TSS COMBINATION, CONFIG #1 FREQ RESPONSE, JULY 22 '80

Figure 4.21

the average lateral acceleration response is much smaller than the peak gain in the lateral acceleration of the second semitrailer. Moreover, the peak of the average lateral acceleration occurs at a lower frequency than does the peak lateral acceleration of the second semitrailer. Therefore, the worst roll behavior of a TSS combination occurs at a steering input frequency which is lower than the frequency at which the second semitrailer exhibits the highest amplification in lateral acceleration.

The magnitude and phase angle of the average lateral acceleration and the lateral acceleration response of the tractor are shown in Figure 4.22 for a tractor-semitrailer combination. The average lateral acceleration, as expected, does not exhibit any amplification over that of the tractor. On comparing Figure 4.22 with Figure 4.21, it is evident that the average lateral acceleration characteristic of the TSS combination does not differ significantly (over the range of reasonable frequencies) from that of a tractor-semitrailer. Hence, on the basis of the linear analysis one can expect the TSS combination to exhibit dynamic rollover thresholds which are only slightly smaller than their steady-state levels.

4.1.5 Yaw/Roll Model. A mathematical model which is capable of simulating the yaw/roll response of multiple articulated vehicles was developed during this study. The model was formulated for the purpose of analyzing the combined directional and roll behavior of tractor-semitrailers and TSS combinations during dynamic maneuvers which approach the rollover limit. The model does not place any limitations on either the number of articulated units or the number of axles which can be represented on a given vehicle. Vehicles equipped with a variety of hitching mechanisms can also be studied by making simple modifications to the computer code.

A detailed description of the differential equations of motion is given in Appendix C. In this section, the description of the model is therefore restricted only to essential features and to the important assumptions made in the process of developing the equations of motion.

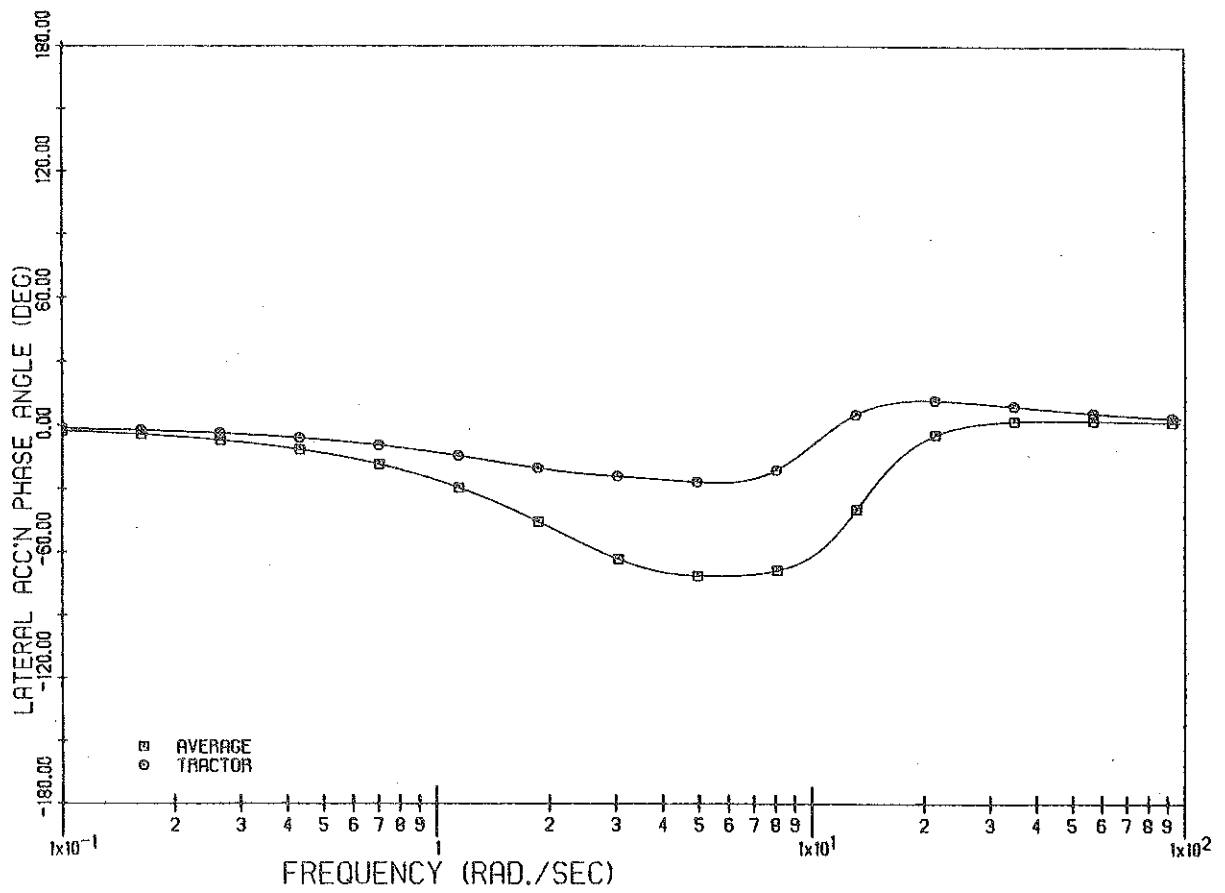

TRACTOR SEMITRAILER, CONFIG #1, FREQ RESPONSE.

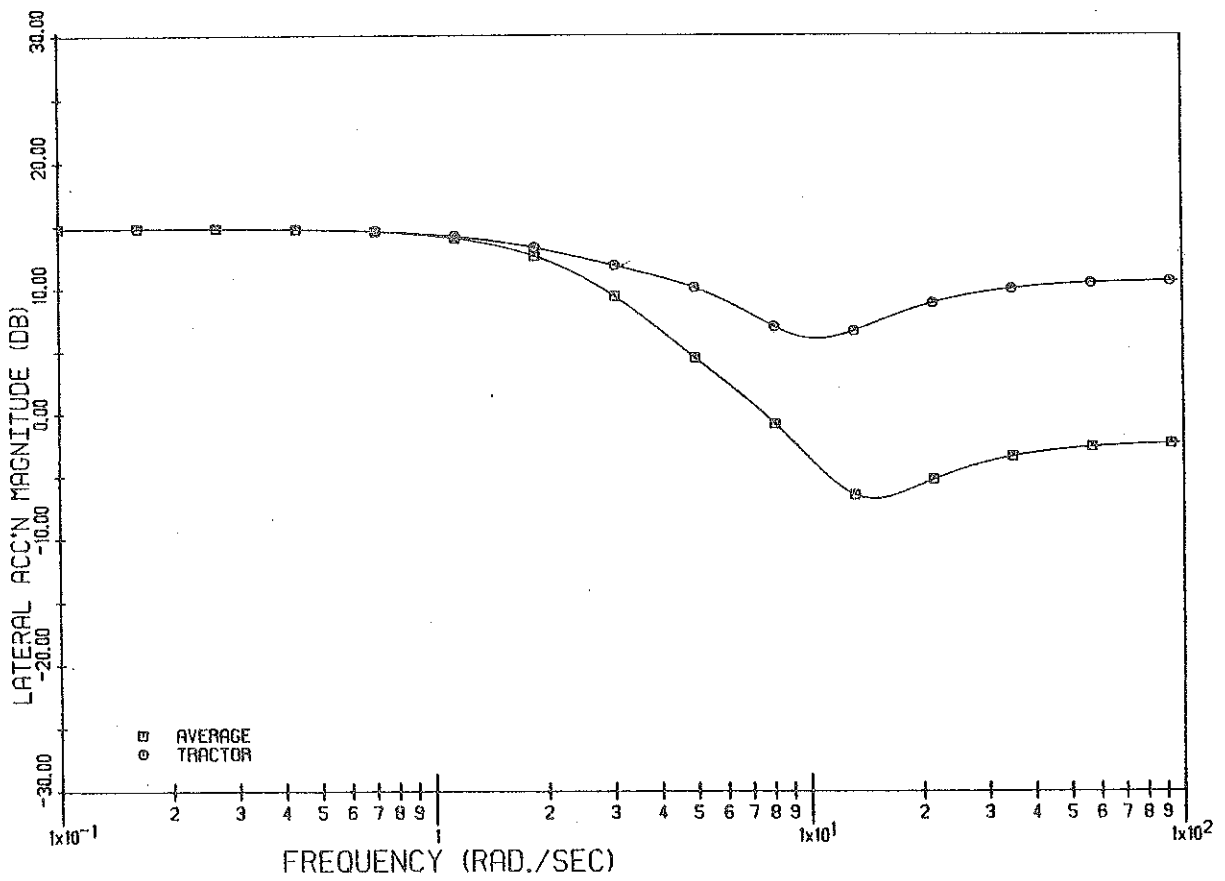

TRACTOR SEMITRAILER, CONFIG #1, FREQ RESPONSE,

Figure 4.22

Degrees of Freedom

The equations of motion of the vehicle are formulated by treating each of the sprung masses as a rigid body with five degrees of freedom, namely: lateral, vertical, yaw, roll, and pitch. The longitudinal degree of freedom is not included, since the forward velocity of the lead unit (or tractor) is assumed to remain constant during the maneuver. The axles are treated as beam axles which can roll and bounce with respect to the sprung masses to which they are attached. The total number of degrees of freedom of a multiple articulated vehicle with N_S sprung masses and N_U axles is therefore given by the expression: $N_{D.O.F.} = 5N_S + 2N_U$.

Features of the Model

The simplifying assumptions made in the process of deriving the equations and the essential features of the model are given below.

1. The vehicle is assumed to travel on a horizontal surface with uniform friction characteristics.
2. Steering system compliance and dynamics are left out of the model and the steering input is assumed to be given directly to the front wheels.
3. The pitch motion of the sprung masses are assumed to be small such that the approximations $\sin \theta_S = \theta_S$ and $\cos \theta_S = 1$ hold.
4. The relative roll angle between the sprung masses and the axles are assumed to be small so that the approximation $\sin (\phi_S - \phi_U) = (\phi_S - \phi_U)$ and $\cos (\phi_S - \phi_U) = 1.0$ hold.
5. As shown in Figure 4.23, the relative roll motion between the sprung and unsprung masses is assumed to take place about a roll center, R , which is at a fixed height beneath the sprung mass. In order to simplify the equations, the suspension springs are assumed to remain parallel to the \vec{k}_{u_i} axis and transmit only compressive or tensile forces. Since the roll center is permitted to slide freely along the \vec{k}_{u_i} axis, all axle forces which act in a direction parallel to the \vec{k}_{u_i}

axis are taken up by the suspension springs, while all axle forces along the \vec{j}_{u_i} axis are assumed to act through the roll center, R_i . When a relative roll motion takes place between the sprung mass and the axles of a leaf-spring-type suspension, the leaf springs tend to be twisted in the roll plane and hence produce an additional roll resisting moment. This effect is represented in the model by an auxiliary roll stiffness parameter, KRS_i .

6. Suspension nonlinearities such as backlash are represented by using a tabular load-deflection input format, shown in Figure 4.24.

7. The model permits the simulation of vehicles equipped with a wide variety of hitching mechanisms. The equations are formulated such that the equations of motion are independent of the constraint equations. Hence, the vehicles equipped with any given hitching mechanism can be analyzed by simply altering the constraint equations (see Appendix C).

8. The nonlinear cornering force and aligning torque characteristics of the tires are represented as tabular functions. The tire forces and moments are computed by a double table look-up for the given vertical load and sideslip angle.

9. The forces acting on each axle are treated independently, i.e., no interaxle load transfer effects are incorporated in the model.

10. Simulations can be performed in the closed-loop or open-loop modes. In the open-loop mode, the time history of the steering input is provided as input to the model. In the closed-loop mode, the trajectory to be followed by the vehicle is specified and the "driver model" [8] computes the steering input that is necessary to accomplish the maneuver.

Validity of the Model

The yaw/roll model was found to be capable of accurately predicting the directional and roll response of tractor-semitrailers and double-trailer-type vehicles. Directional response data collected during the double-tanker study [2] conducted in 1978 was used for the purpose of

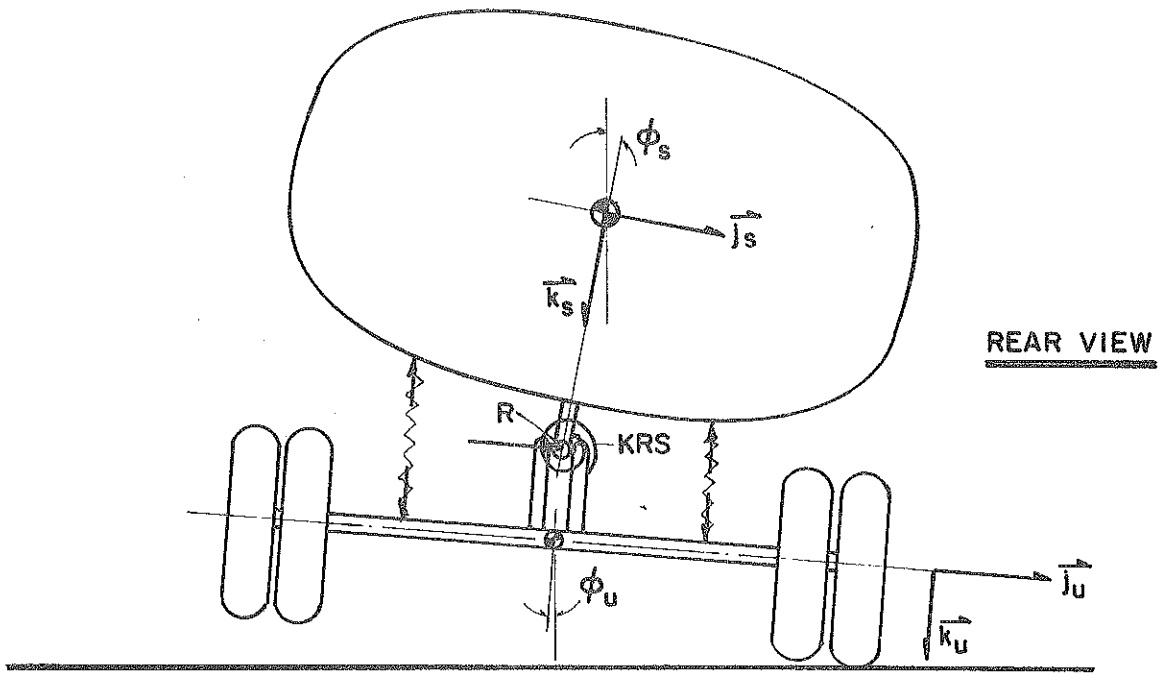

Figure 4.23. Representation of axles and suspension springs in the yaw/roll model.

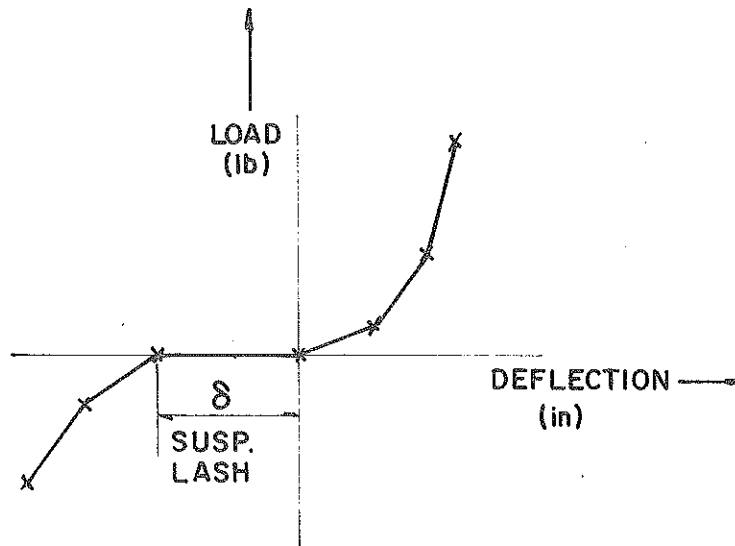

Figure 4.24. Representation of suspension nonlinearities in the yaw/roll model.

validating the yaw/roll model. The match between test data and simulated response was found to be good even for severe maneuvers which result in wheel lift-off. Since tractor front-wheel angle measurements had not been made during the double-tanker experiments, steering-wheel time histories were used to estimate the front-wheel angles.

Shown in Figure 4.25 is a comparison of test data and simulation results for a two-second lane-change maneuver conducted on a 55-foot conventional double tanker at a speed of 50 mph. A schematic diagram of the tanker is shown in Figure 4.26. This relatively mild maneuver resulted in a peak tractor lateral acceleration of about 0.1 g and a peak lateral acceleration of the full trailer which is in the vicinity of 0.2 g. The roll angles are seen to be small and the maneuver is well within the linear regime. The agreement between test data and simulated response can be seen to be excellent for all of the measured variables. The simulation makes an accurate prediction of the amplification and the timing of the full trailer's response.

A more severe lane-change maneuver performed on the same 55-foot double tanker is shown in Figure 4.27. The peak lateral acceleration response of the full trailer is in the vicinity of 0.3 g and exhibits a highly nonlinear response. The combination of large slip angles (which reach 6 degrees in the simulation) and a complete lift-off of the left-hand side tires on the full trailer cause the lateral tire forces to saturate and hence produce the dwell in the lateral acceleration response at the point marked "x" in Figure 4.27. Except for some minor discrepancies, the simulation is found to predict the nonlinear lateral acceleration response of the full trailer rather well. The peak full trailer roll angle predicted by the simulation is higher than the measured roll angle by about 0.7 degree. The absence of accurate data on suspension backlash (the backlash was assumed to be 1.5 inches for the simulation) and spring stiffness could have resulted in this discrepancy.

Another example of the capability of the yaw/roll model in predicting limit behavior is portrayed in Figure 4.28. The test data shown in Figure 4.28 is for the tractor-semitrailer portion of the double tanker. In this experiment, the backlash on the semitrailer suspension

— MEASURED
- - - SIMULATED

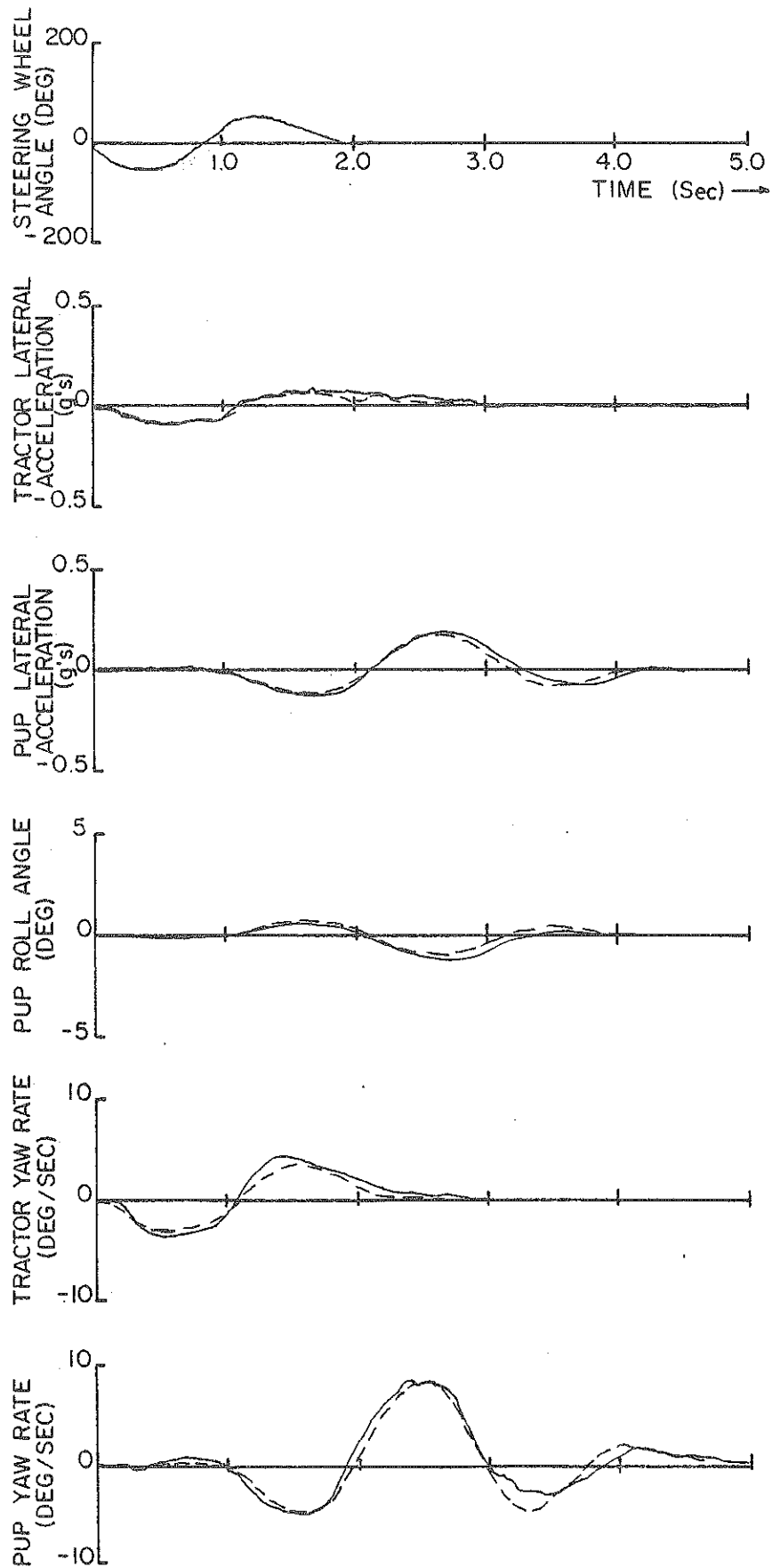
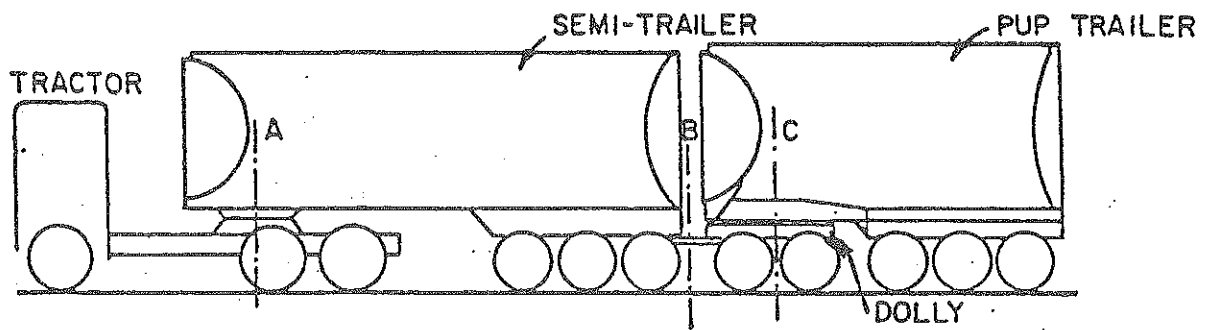

Figure 4.25. Fully loaded conventional 55-foot double tanker - forward speed 50 mph.



55 FT, 11 AXLE DOUBLE BOTTOM TANKER

Figure 4.26

—— MEASURED
- - - SIMULATED

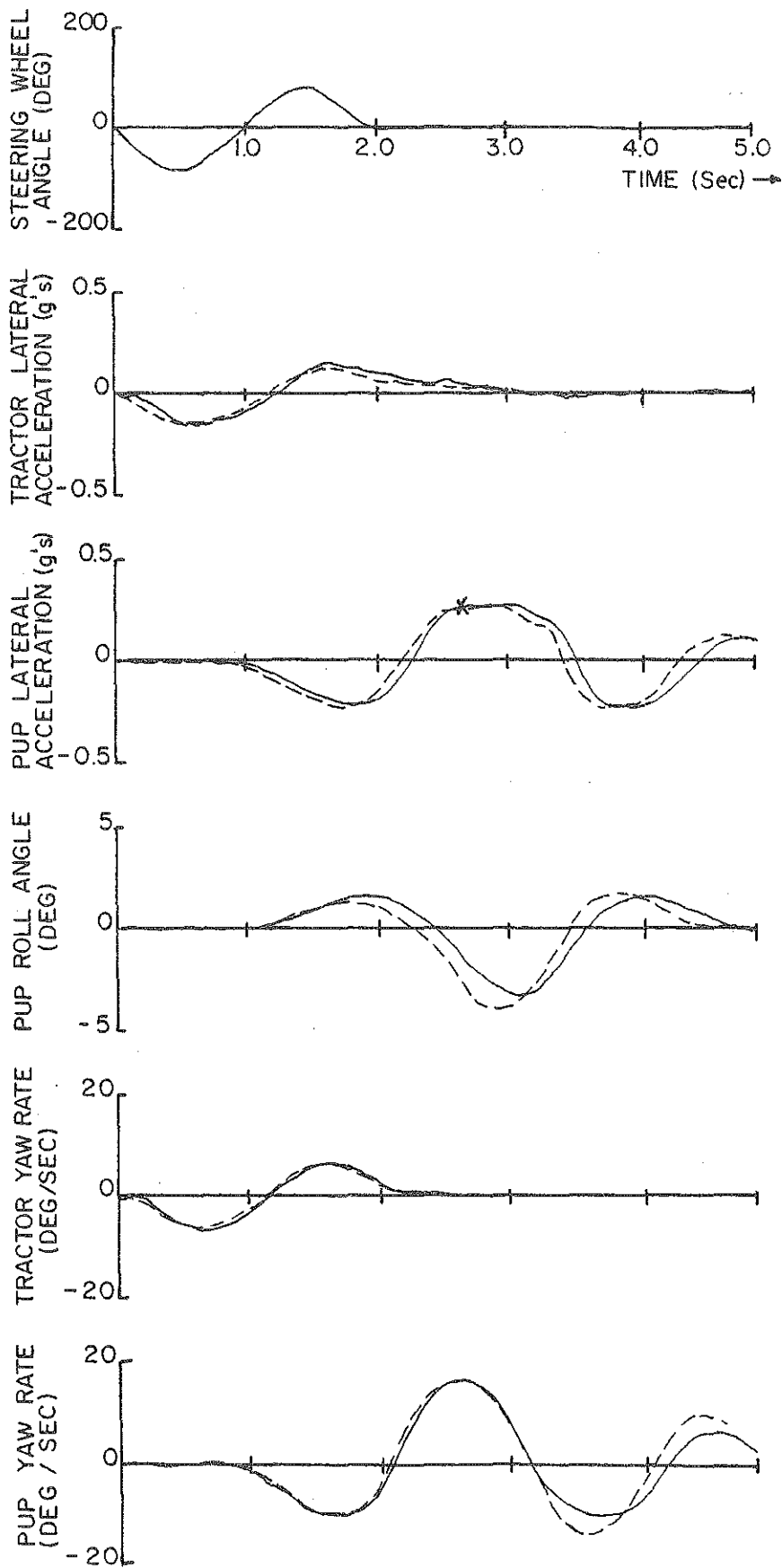

Figure 4.27. Severe lane change, performed on a fully loaded 55-foot double tanker - forward speed 39 mph.

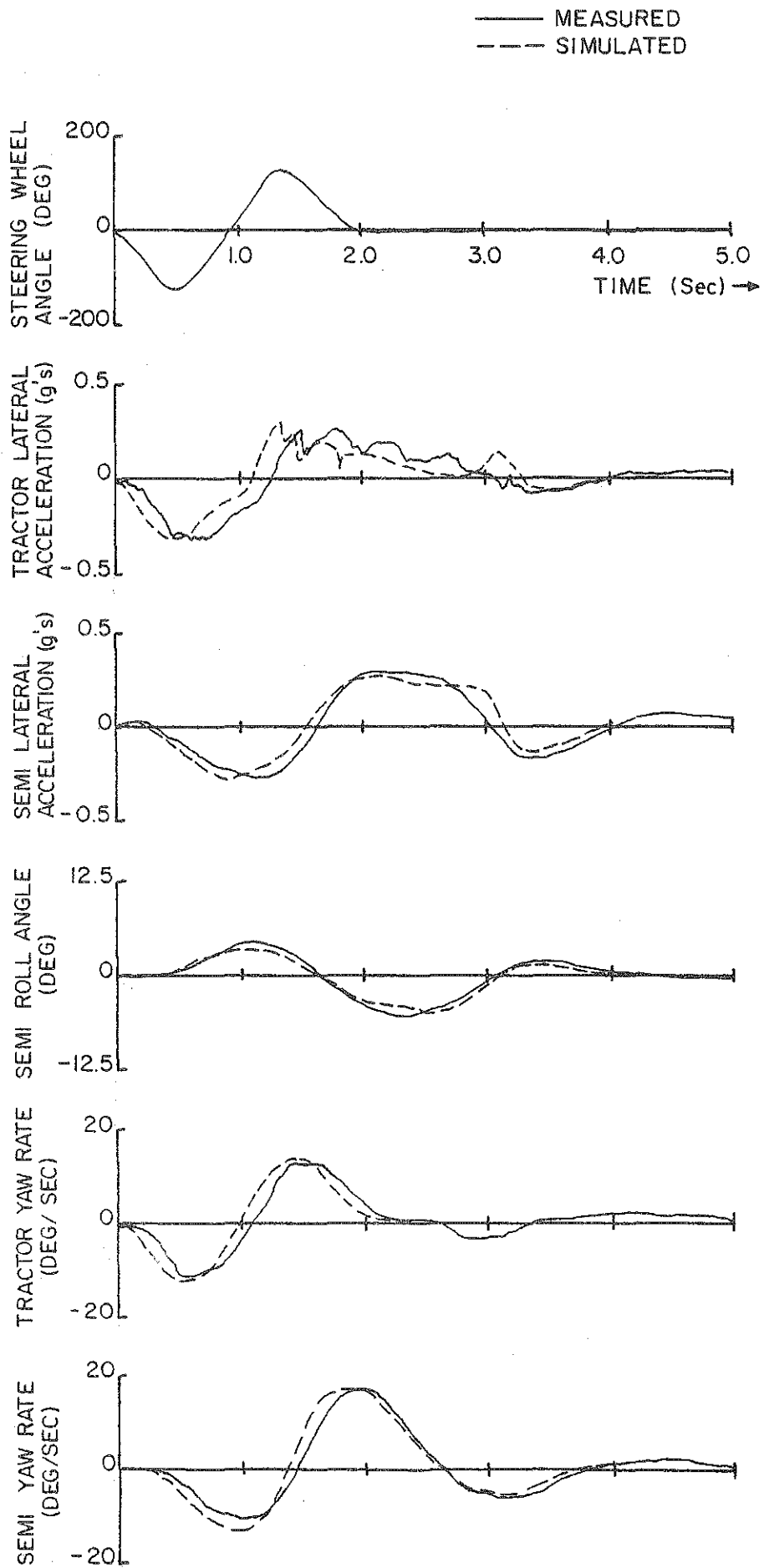

Figure 4.28. Tractor-semitrailer portion of 55-foot double tanker - forward speed 44 mph.

springs was reduced to 0.5 inch by the installation of spring lash reduction devices. Several interesting observations can be made with regard to this maneuver. Both the tractor and the semitrailer lateral accelerations reach relatively high peak levels which are in the vicinity of 0.3 g. The simulation results indicated that the tires on the left-hand side of the semitrailer lifted off the ground at 1.8 seconds and remained off the ground until about 2.9 seconds. This wheel lift-off once again produces the long dwell in the semitrailer lateral acceleration response. The lift-off of the semitrailer tires during the second half of the maneuver produces roll-induced oscillations in the lateral acceleration response of the tractor. The model is seen to only qualitatively match the measured oscillation in the tractor lateral acceleration response.

In summary, it can therefore be stated that the yaw/roll model is accurate enough to predict the transient response of both single and double trailers during maneuvers which approach the rollover limit. Hence the model with the proper implementation of the constraint relationships can be extended to study the directional dynamics of other multiple articulated vehicles.

Maneuver Used for Evaluating Yaw/Roll Behavior

The directional and roll dynamics of the candidate vehicle designs were evaluated by investigating their response to a standardized maneuver. Both open-loop maneuvers (in which the time history of the steering wheel is prescribed) or path-follower type, closed-loop maneuvers (in which the trajectory to be followed by the tractor is prescribed) were considered for use for this "standard" maneuver. It was determined that a closed-loop maneuver would be preferable for comparing the dynamic offtracking qualities of the vehicles since it is possible to achieve a standardized tractor trajectory, relative to which the offtracking of the trailing units can be defined.

A short-duration, obstacle-avoidance type, single-lane-change maneuver was chosen in which the tractor is caused to cover a lateral translation equal to a full, 12-foot, lane width in about 3.5 seconds

from a steady speed of 50 mph. An example of the prescribed trajectory and the actual path followed by the tractor center of gravity are shown in Figure 4.29. The tractor can be seen to overshoot the lane edge by about 6 inches. During the closed-loop simulation, the driver model computes and applies the front-wheel angle needed to accomplish the maneuver as shown in Figure 4.30. The speed and geometric constraints involved in this maneuver result in peak lateral acceleration levels at the tractor which are in the vicinity of 0.3 g.

Parameters for the Candidate Vehicles

The yaw/roll analysis was performed for 17 of the 20 vehicle layouts which were initially considered feasible. The three largest capacity tractor-semitrailer configurations (configurations #5b, #6, and #7) were dropped from the list of feasible vehicles on the basis of the excessive levels of lateral fifth wheel force discussed previously in Section 4.1.2.

The tractor was assumed to have a track width of 96 inches. The track width of the trailer axles and the width of the tanks were assumed to be 102 inches. The parameters for the candidate vehicles are listed in Appendix D. The lateral force and aligning torque characteristics of the tires are also included in Appendix D.

Results

Examples of the trajectory, lateral acceleration, and roll angle responses exhibited by a 59-foot TSS combination during the single-lane-change maneuver are shown in Figures 4.31, 4.32, and 4.33, respectively. Certain response numerics have been defined for reducing the time history data to a simpler format so as to aid in evaluating the dynamic performance of the candidate vehicles and in gaining a general understanding of the influence of payload capacity and tanker layout on the directional and roll response characteristics.

Dynamic Offtracking. During slow-speed maneuvers, the rear units of an articulated vehicle offtrack towards the center of the prescribed turn. On the other hand, transient maneuvers executed at highway speeds produce large levels of lateral acceleration and sideslip angle which

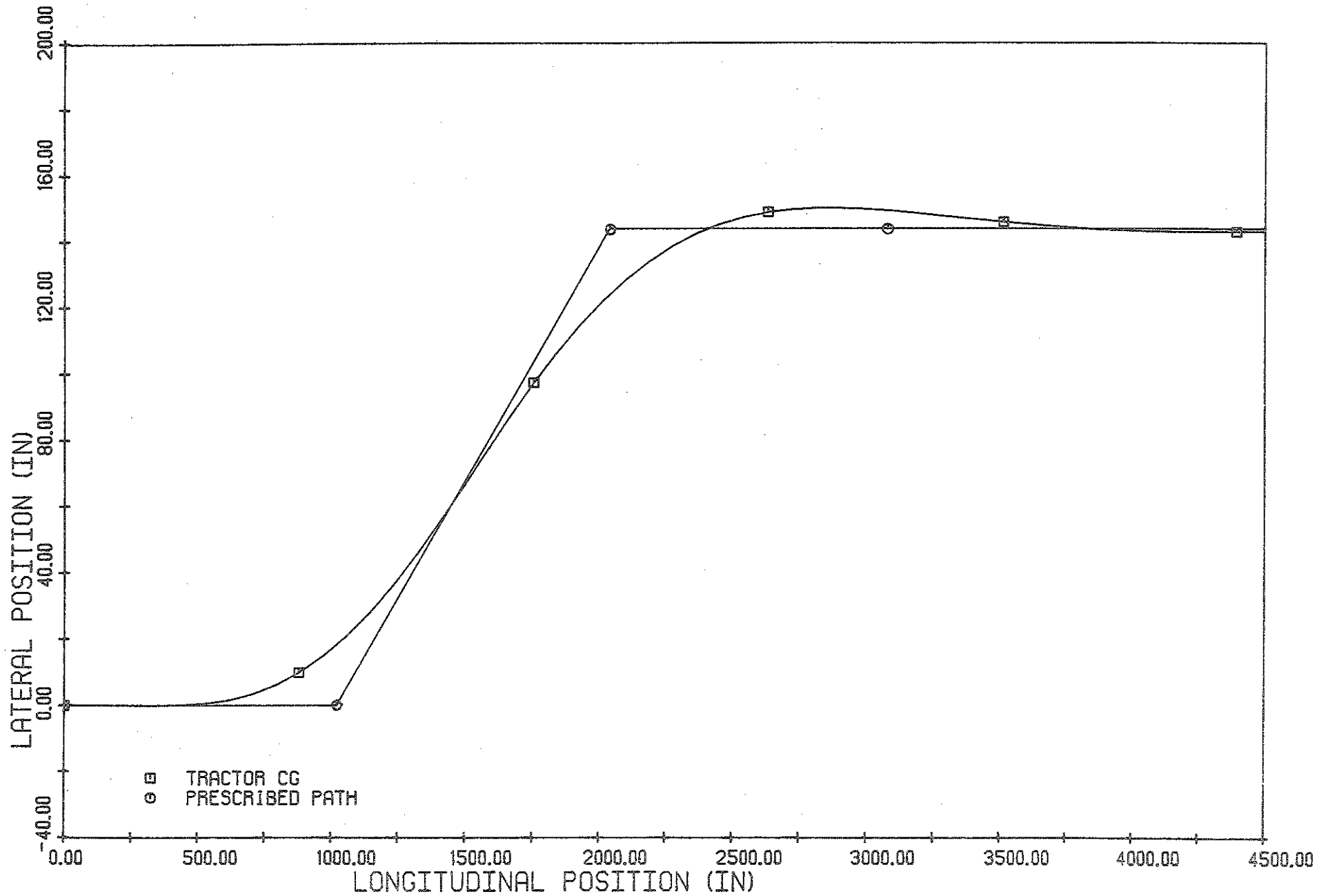

TRACTOR-SEMI, CONFIG #2A, TRAJECTORY OF TRACTOR DURING LANE CHANGE

Figure 4.29

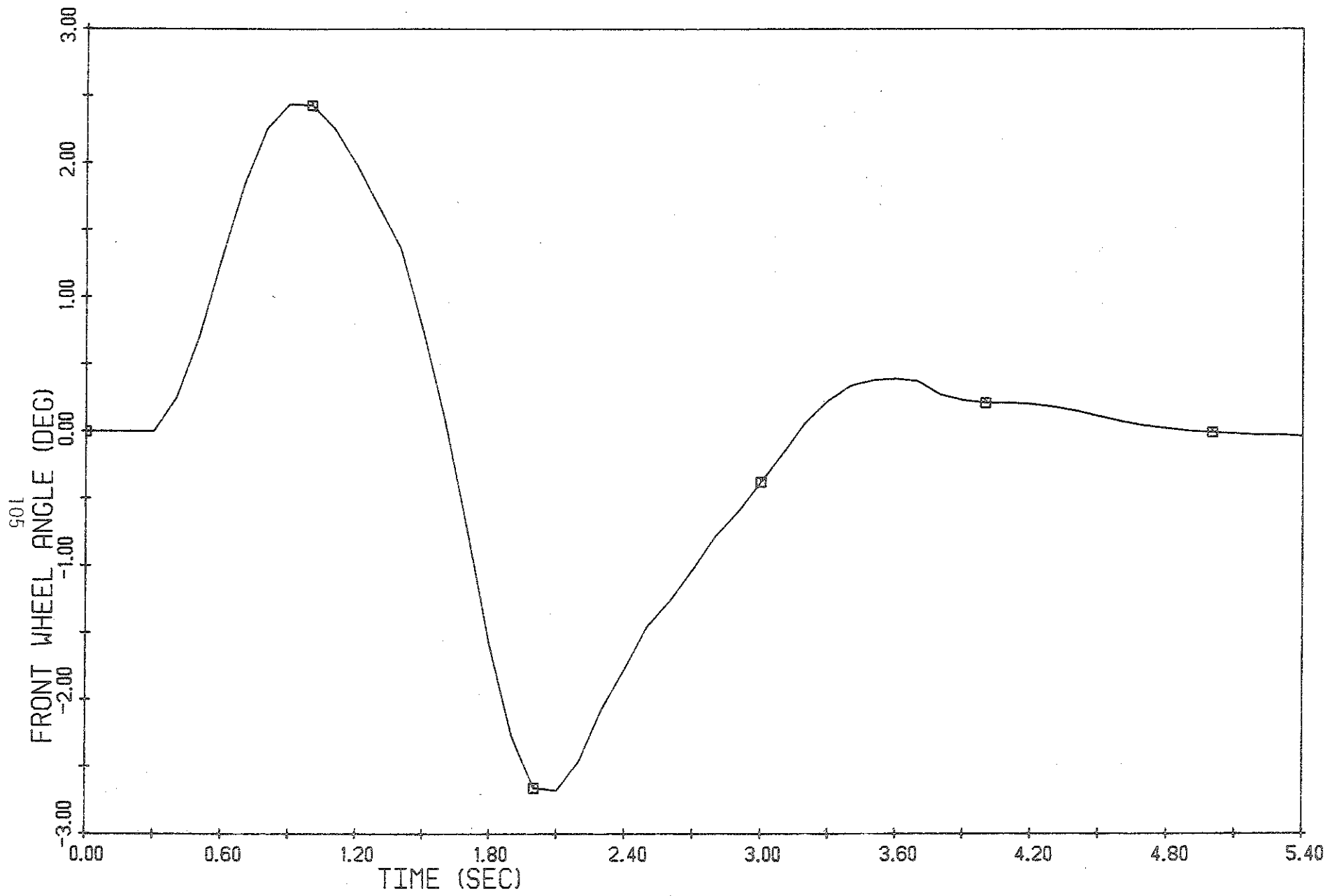

TRACTOR-SEMI, CONFIG #2A, SINGLE LANE CHANGE, F.W. ANGLE

Figure 4.30

901

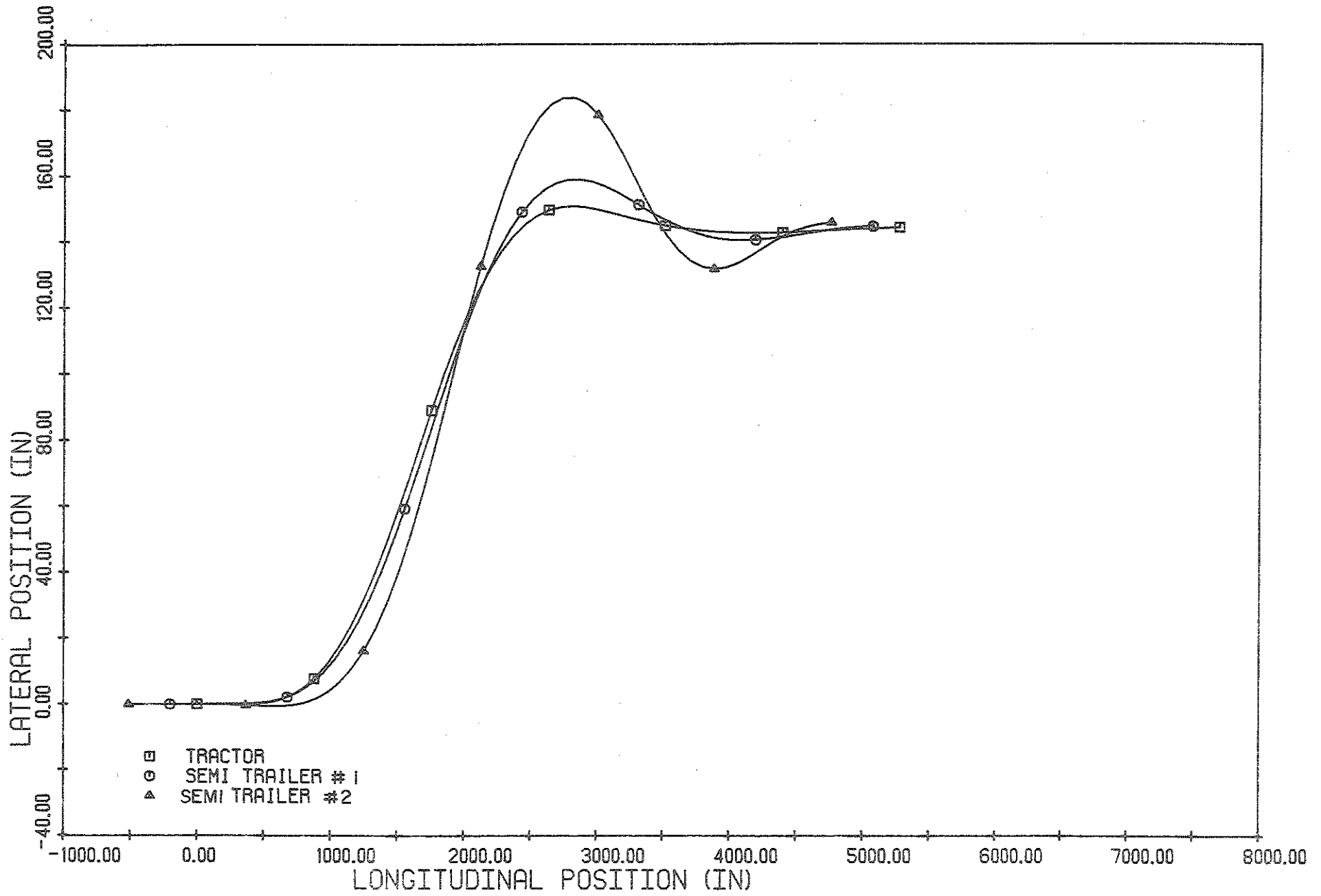

TSS COMBINATION, CONFIG #I, SINGLE LANE CHANGE

Figure 4.31

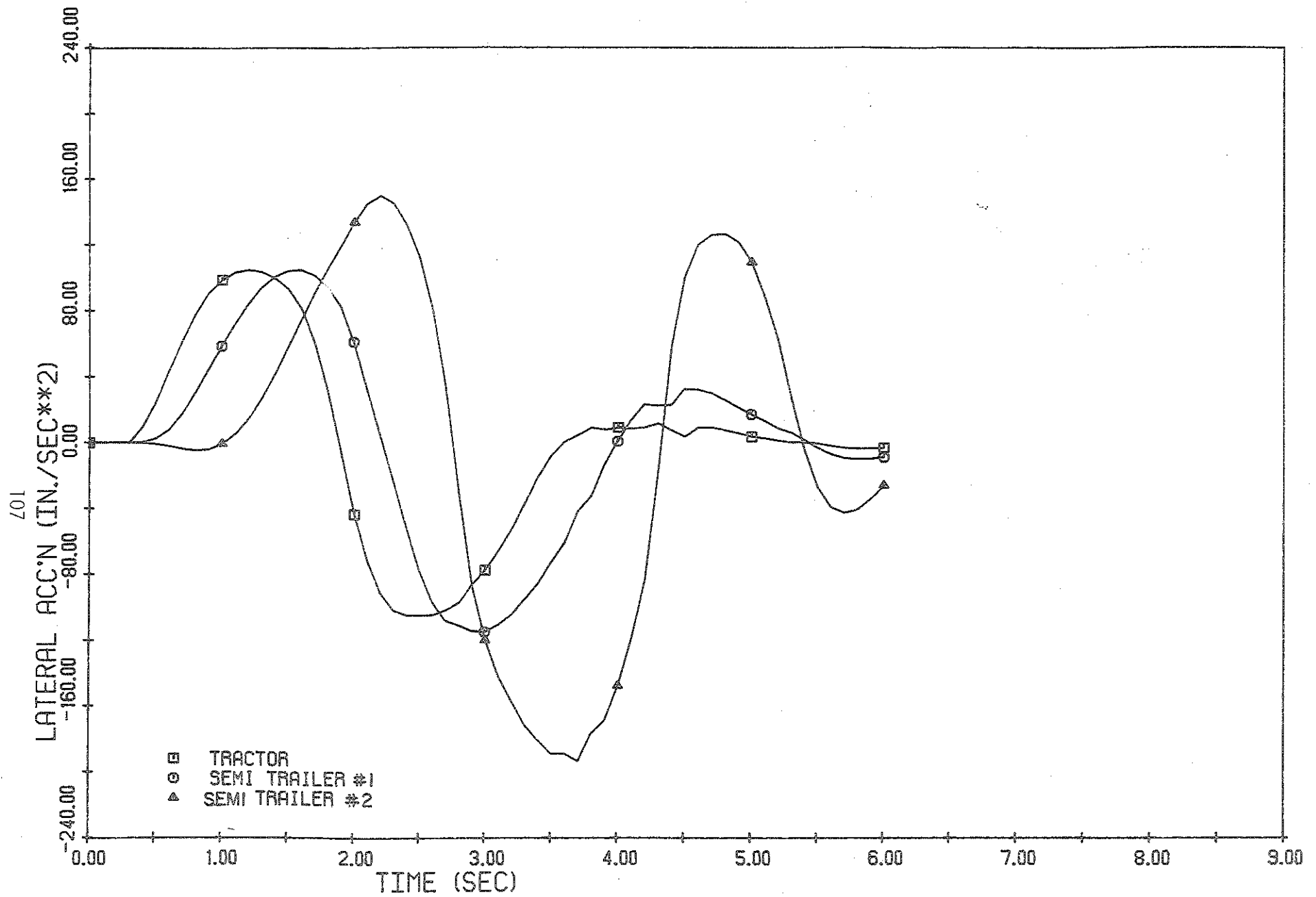

TSS COMBINATION, CONFIG #I, SINGLE LANE CHANGE

Figure 4.32

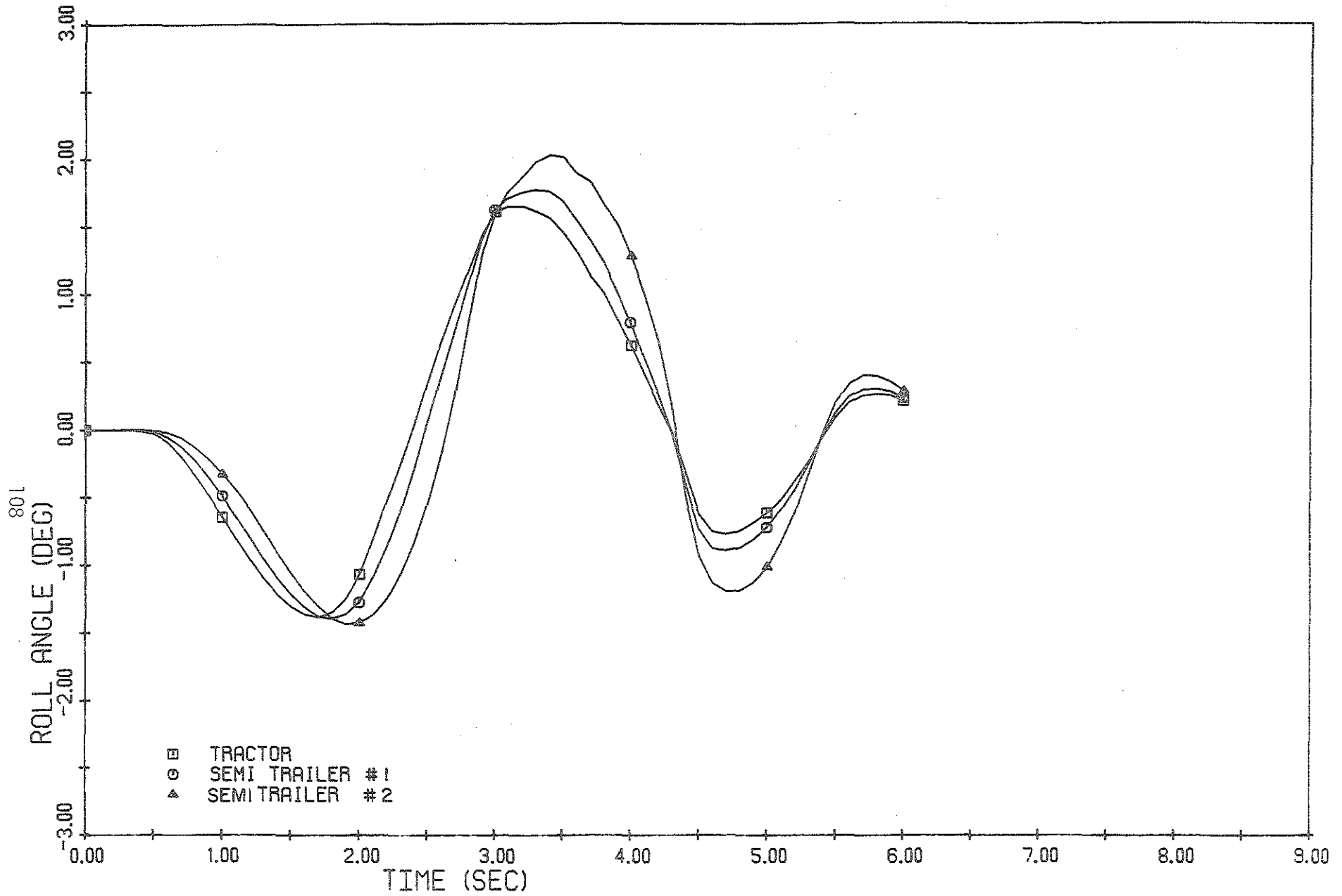

TSS COMBINATION, CONFIG #I, SINGLE LANE CHANGE

Figure 4.33

cause the trailers to offtrack in a direction which is away from the center of the turn. The high-speed offtracking quality can be very important in an accident scenario. High levels of offtracking during emergency maneuvers can cause the tires on the rear axles of the vehicle to leave the roadway and hence initiate a rollover of the entire vehicle.

With reference to Figure 4.31, the second semitrailer of the TSS combination is seen to substantially overshoot the 12-foot lane change executed by the tractor. The maximum lateral distance by which the rearmost axle of the vehicle overshoots the 12-foot lane change was chosen as an index of the dynamic offtracking quality of the vehicle.

Figure 4.34 shows the dynamic offtracking numeric plotted as a function of the payload capacity for all of the candidate vehicle configurations. The TSS combinations are seen to exhibit much poorer dynamic offtracking qualities than the candidate tractor-semitrailer configurations. The dynamic offtracking levels are seen to increase with payload volume for the tractor-semitrailer as well as the TSS combination.

Good low-speed offtracking qualities seem to go hand in hand with poor dynamic offtracking qualities, and vice versa. For example, the 59-foot TSS combinations, which have the best slow-speed offtracking qualities (see Figure 4.10) among the candidate vehicles, also have the poorest dynamic offtracking qualities. The dynamic offtracking levels exhibited by the 59-foot TSS combinations are almost 100 percent higher than the levels exhibited by the tractor-semitrailers of the same payload volume.

Upon comparing the dynamic offtracking levels exhibited by the 59-foot and 65-foot TSS combinations, one can observe that increasing the overall length of the TSS combinations from 59 feet to 65 feet (an increase of 10 percent) produces a reduction in the dynamic offtracking level of approximately 20 percent.

Among the semitrailer combinations, those equipped with an 18,000-lb capacity spread axle (#2b, #3b, #4b) are found to exhibit dynamic offtracking levels which fall above the pattern followed by the rest of the tractor-semitrailers.

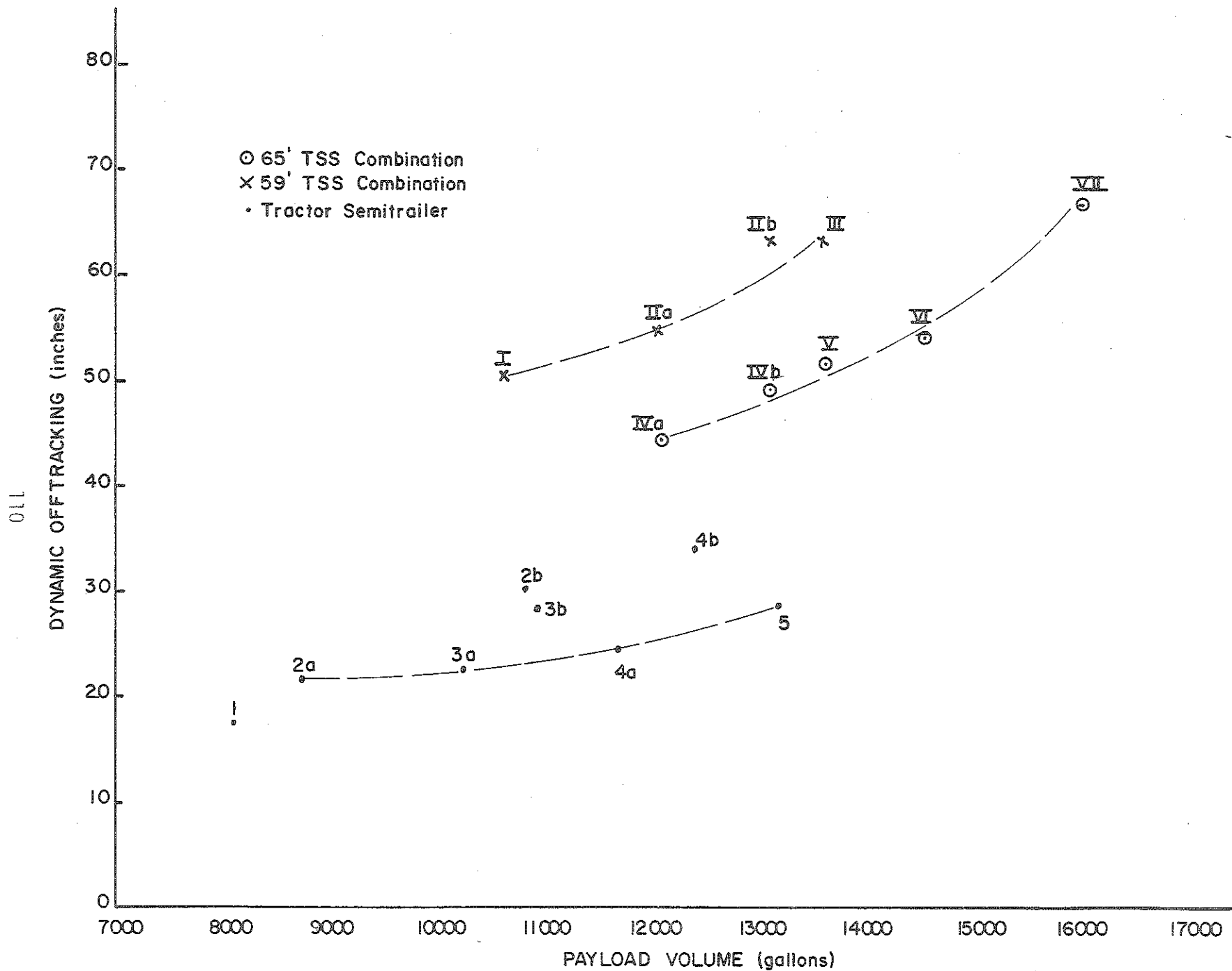

Figure 4.34. Dynamic offtracking numeric for the candidate vehicle configurations.

Amplification of Lateral Acceleration. The amplified lateral acceleration responses exhibited by the trailers of the candidate vehicle configurations were analyzed in Section 4.1.4 using a linear yaw plane model. We shall now use the results from the lane-change maneuver to determine the extent to which the nonlinear effects of large sideslip angles and side-to-side load transfers affect the amplification of the lateral acceleration response.

Firstly, in Figure 4.32, we note that the second half of the lane-change maneuver produces the highest amplification of the peak lateral acceleration. The numeric for the amplification of lateral acceleration is therefore defined with reference to the second peak in the tractor and the trailer lateral acceleration responses. The amplification of the lateral accelerations which was exhibited by each of the candidate vehicles is plotted as a function of payload volume in Figure 4.35. We shall first discuss the amplification characteristics exhibited by the tractor-semitrailers, followed by a discussion of the characteristics exhibited by the tractor-semitrailer-semitrailer combinations.

Tractor/semitrailers - Figure 4.35 indicates that the tractor-semitrailer configurations do not exhibit any significant amplification in the lateral acceleration response. These results confirm the basic understanding that was gained from the linear yaw plane analysis.

Increase in payload volume is seen to produce only a small increase of the amplification factor. The tractor-semitrailer configurations whose axles are more heavily loaded (16,000 lb/axle on configuration #1 and 18,000 lb/axle on the spread axle of configurations #2b, #3, and #4b) exhibit slightly higher amplification levels than the rest of the tractor-semitrailers.

The amplification of peak lateral acceleration is below 1.1 for all of the tractor-semitrailer combinations. Therefore, from the point of view of rearward amplification, no major problem seems to exist with any of the tractor-semitrailer configurations. The semitrailers equipped

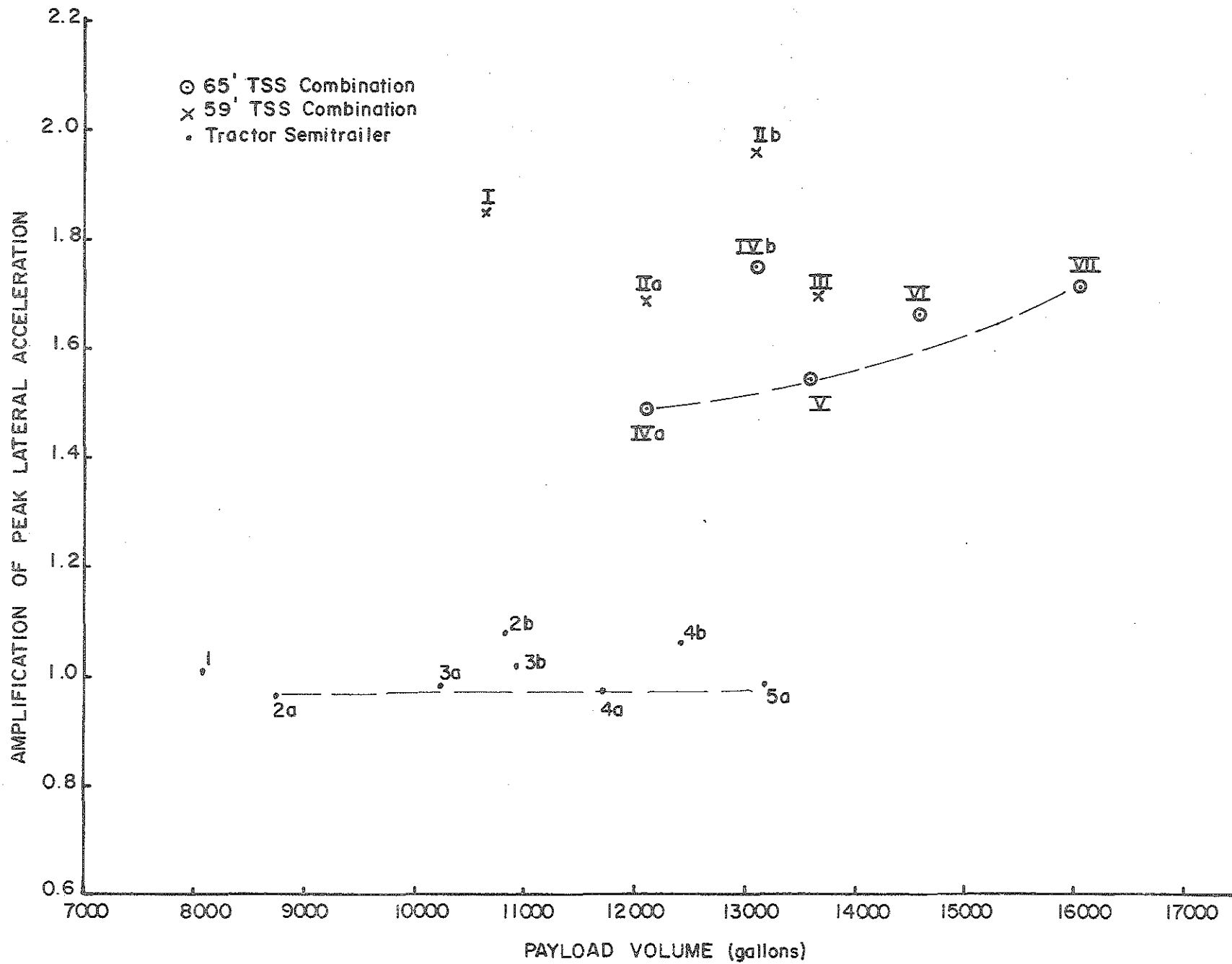

Figure 4.35. Amplification of lateral acceleration exhibited by the candidate vehicle configurations.

with axles which are loaded to 13,000 lb/axle are found to perform better than the vehicles equipped with the more heavily loaded spread axles.

Tractor-semitrailer-semitrailer combinations - All of the TSS combinations are found to exhibit a considerable amount of rearward amplification in lateral acceleration. The linear yaw plane analysis indicated a peak lateral acceleration gain which ranged from 1.27 to 1.6 for the TSS combinations. Calculations performed using the non-linear yaw/roll model show that large sideslip angles and side-to-side load transfers experienced during the lane-change maneuver cause the TSS combinations to exhibit higher amplification levels, ranging from 1.49 to 1.95.

On comparing the 65-foot TSS configuration with the 59-foot vehicles, we notice that for vehicles with the same payload capacity and axle distribution, the 65-foot versions exhibit lower levels of amplification than the 59-foot versions. This is due to a combination of two effects, namely:

1. The longer vehicle has longer effective wheelbases for the first and second semitrailers. The increased wheelbase results in improved yaw stability and hence a decrease in the amplification of the lateral acceleration.
2. For the same payload capacity, the longer vehicle has a lower c.g. height. The lower c.g. height means lower levels of side-to-side load transfer and hence lower levels of amplification of the lateral acceleration response.

The highest amplification is exhibited by vehicles which are designed with small capacity, short wheelbase, second semitrailers, such as configurations #3, #4b, and #6b.

Peak Roll Angles. Although the foregoing yaw response amplifications reveal an undesirable vehicle characteristic, it must be noted that the amplified response exhibited by the rearmost semitrailer of the TSS combinations does not, by itself, establish that a commensurately

poor rollover immunity will result, since the tractor and the trailers are all rigidly coupled together by fifth wheel arrangements. Thus we need to examine, separately, the effects of the amplified response on the peak roll angles observed during the maneuver.

The maximum roll angles achieved during the lane-change maneuver were observed during the second half of the response. The peak roll angles exhibited by each of the candidate vehicles in the lane-change maneuver are plotted in Figure 4.36, with the payload capacity of the vehicles as the abscissa and peak roll angle as the ordinate. We shall first discuss the roll behavior of the tractor-semitrailer, followed by a discussion of the behavior of the TSS combination.

Tractor-semitrailers - The first observation we can make about the tractor-semitrailer configurations is that the vehicles equipped with heavily loaded semitrailer axles (16,000 lb/axle for configuration #1 and 18,000 lb/axle for the spread axles of configurations #2b, #3b, and #4b) exhibit distinctly higher levels of roll angle than the vehicles which are designed with semitrailer axles which are loaded to only 13,000 lb/axle.

The heavily loaded axles were assumed to have the same suspension properties as the lightly loaded axles. Therefore, the vehicles equipped with the heavily loaded axle have a higher roll compliance (in terms of deg/g of lateral acceleration) and hence exhibit higher peak roll angles than a vehicle of the same size but equipped with more lightly loaded axles.

Considering the tractor-semitrailer configurations that have semitrailer axles which are loaded to 13,000 lb each (configurations #2a, #3a, #4a, and #5a), it is interesting to note that, for reasons described earlier in Section 4.1.3, increasing payload volume results in peak roll angles which initially decrease and then, above 10,000-gallon tank capacities, tend to increase.

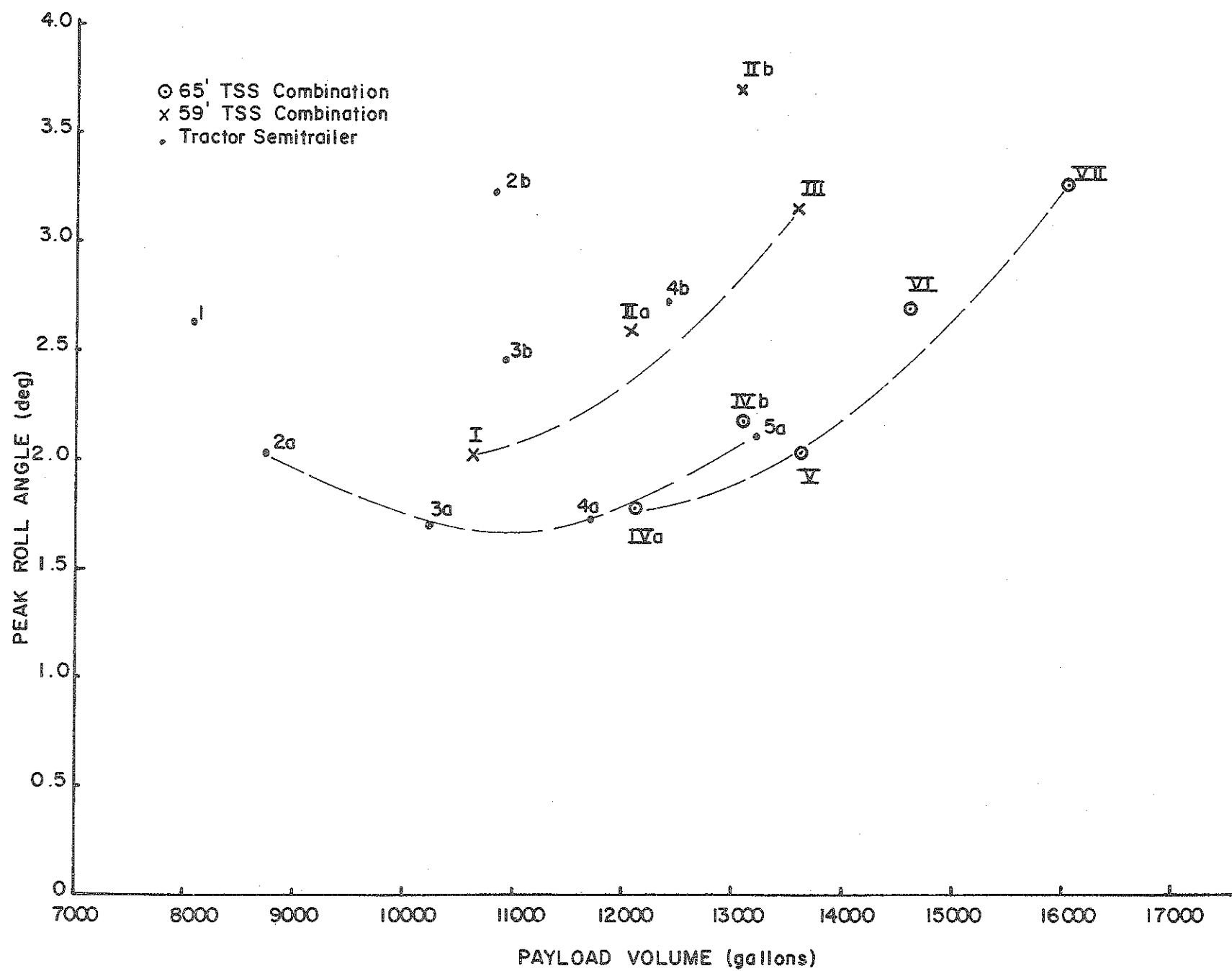

Figure 4.36. Peak roll angles exhibited by the candidate vehicle configurations.

Tractor-semitrailer-semitrailer combinations - The TSS combinations show a consistent increase of the peak roll angle as the payload volume is increased. For the same payload capacity, the peak roll angles of the 59-foot versions are around 50 percent higher than the roll angles of the 65-foot variety. This can be explained by the fact that (1) the 59-foot versions exhibit a higher amplification in lateral acceleration than the 65-foot versions and (2) because of their shorter overall length have a higher c.g. height.

It is interesting to note that the 65-foot TSS combinations, despite the amplification of lateral acceleration, exhibit smaller peak roll angles than the tractor-semitrailer combinations of the same payload capacity. Because of their additional length, the 65-foot versions have a lower c.g. height than the tractor-semitrailer, which more than compensates for any roll destabilizing effect produced by the amplified lateral acceleration of the rear trailers. It can therefore be stated that, from the point of view of dynamic roll stability, the 65-foot TSS combinations are comparable to tractor-semitrailer combinations of the same payload capacity.

One vehicle design feature which is needed for a TSS combination to achieve the high levels of roll stability shown above is a torsionally stiff coupling between the two trailers. It was found in a crude examination of this parametric sensitivity that a torsional stiffness of 750,000 in-lb/deg, existing between the fifth wheel assembly and the rigid tank structure of the first semitrailer, was adequate for assuring minimal "roll overshoot" of the second semitrailer relative to the first.

4.2 Effect of Vehicle Design Parameter Variations on Rollover Threshold

The effect of a variety of design changes on the rollover threshold of gasoline tankers were analyzed using the static roll plane model which is described in Section 4.1.3.

The analysis is aimed at determining the extent to which the steady turning rollover threshold of tank vehicles can be improved by:

- 1) adopting tank shell designs which lower the c.g. height of the vehicle,
- 2) by increasing the track width of the tractor and the trailer, and
- 3) by increasing the roll stiffness of the trailer suspensions.

The results indicate that even small improvements under each of these categories can, when combined, lead to significant improvements in the rollover thresholds of tank vehicles. In the discussion to follow, the sensitivity of rollover threshold to design changes which fall into each of the above three categories will be analyzed.

4.2.1 Tank Cross-Section Geometry. The c.g. height of a tank vehicle can be lowered by adopting tank profiles which require smaller tank cross-section heights than the elliptical cross-sections which are commonly used for gasoline tankers. The tank cross-section geometry considered here is one that can be specified with the aid of five basic dimensions, which are illustrated in Figure 4.37. They are:

- 1) top and bottom radii, R_1
- 2) side wall radius, R_2
- 3) blend radius, R_3
- 4) tank width, H_1
- 5) tank height, H_2

Expressions which relate the area of the tank cross-section to these five tank profile parameters can be derived by applying the principles of simple planar geometry. The derivation of the tank cross-sectional area equation is given in Appendix E. A computer program which is convenient for making tank layout calculations is also included in Appendix E.

A numeric which is convenient for comparing various tank profiles is the tank cross-section efficiency, η . η is defined as the ratio of

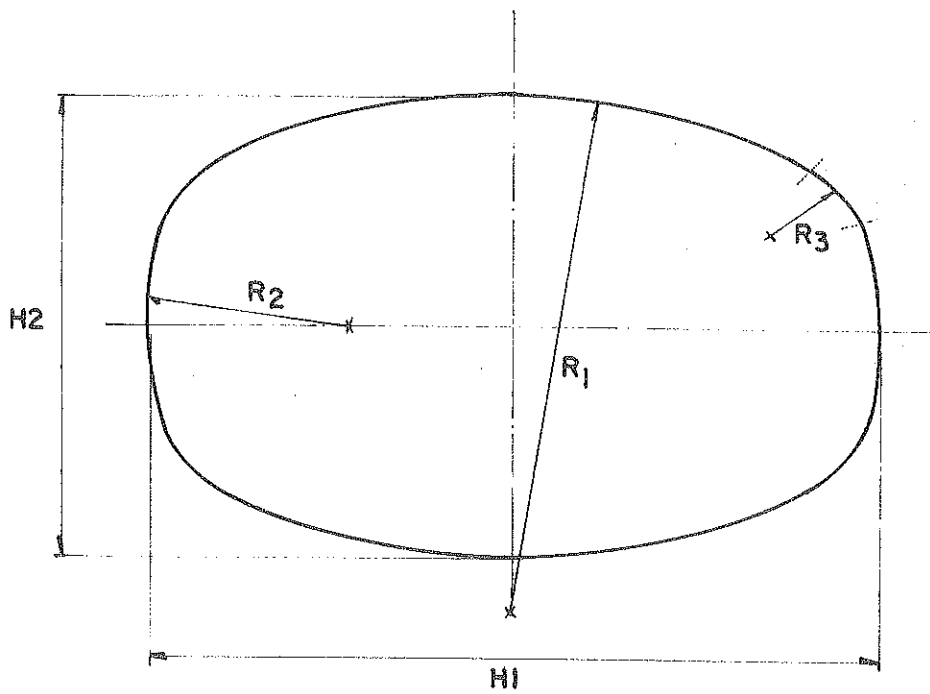

Figure 4.37. Parameters needed to specify tank cross-section geometry.

the tank-cross sectional area to the area of the enveloping rectangle of sides H_1 and H_2 . The higher the efficiency of a profile, the smaller is the shell height required for a given cross-sectional area. A rectangular tank, therefore, has the highest efficiency of 100 percent, while an elliptical tank (area = $H_1 H_2 \pi / 4$) has an efficiency of $\pi/4 = 78.5$ percent.

The effect of shell curvature on cross-sectional efficiency is illustrated in Figure 4.38 for a tank which is 96 inches wide and 65 inches high. For the purposes of this plot, the top and bottom radius, R_1 , and the side wall radius, R_2 , are assumed to be equal. The figure shows lines of constant cross-sectional efficiency for values of R_1 and R_2 which range from 60 inches to 120 inches and a blend radius, R_3 , which varies from 0 to 40 inches. A typical MC306 gasoline tank which has an efficiency of approximately 79 percent is represented in this figure by point A ($R_1=R_2=70''$ and $R_3=27''$). It can be seen that if major improvements in the cross-sectional efficiency of an MC306 tank are to be made, changes have to be made in the top and side shell radii, as well as the blend radius, R_3 . Maximum gain in efficiency can be achieved by moving the design point A along the line xx, drawn normal to the constant efficiency curves. An efficiency of 100 percent can, of course, be achieved by utilizing a zero blend radius, R_3 , and an infinitely large value for R_1 and R_2 , i.e., a rectangular cross-section. It is well known, however, that sharp corners and flat walls lead to structural problems. Sharp corners result in high levels of stress concentration, while flat walls lead to oil canning effects (i.e., the flat walls do not remain stable in shape under alternating hydrodynamic loads).

The proposed tank profile B (with an 89-inch top and side radii and a 15-inch blend radius) is shown in Figure 4.38. The proposed tank cross-section is a compromise between the rectangular cross-section which is ideal for lowering the c.g. height but structurally poor, and the elliptical cross-section which has poor cross-sectional efficiency but good structural qualities. The cross-section B has an efficiency of 84.7 percent for a 96-inch-wide by 65-inch-high profile. Due to the

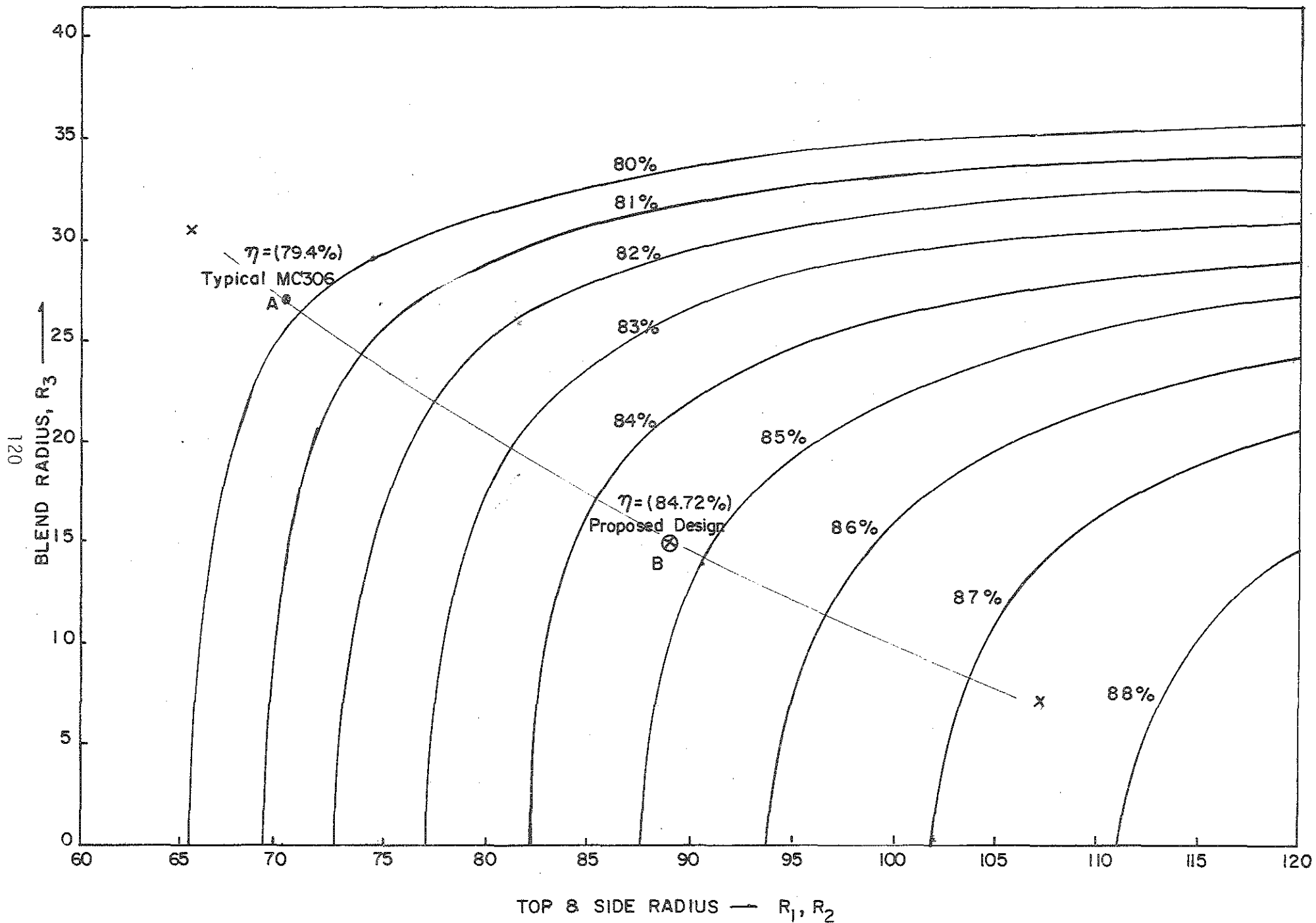

Figure 4.38. Influence of shell curvature on the cross-sectional efficiency of a 96-inch-wide by 65-inch-high tank.

increased efficiency of the profile B, for the same cross-sectional area, the height of the tank shell can be reduced by 4 inches as compared to profile A. The conventional MC306 tank cross-section A, and the proposed higher efficiency tank profile B are shown superimposed in Figure 4.39.

4.2.2 Tank Side-View Profile. Lowering the bottom of the tank shell can lead to substantial improvements in rollover threshold, over and above what could be achieved by the adoption of a more efficient tank cross-section. The extent to which the bottom can be lowered at the front end of a semitrailer is constrained by the height of the tractor fifth wheel and the height of the structural members which make up the fifth wheel coupler plate assembly. For a fifth wheel height of 50 inches (which is typical), it is considered impractical to reduce the height of the front end of the tank bottom below 56 inches. On the other hand, it is structurally feasible to lower the bottom at the rear end of the tank to as low as 46 1/2 inches above ground level. Hence, a reduction in c.g. height can be achieved by the use of different tank cross-section profiles for the front and rear ends of the tank.

Figure 4.40 shows the semitrailer portion of an eight-axle tractor-semitrailer with a 56-inch bottom height at the front end and a 46 1/2-inch bottom height at the rear. The influence of c.g. height on the rollover threshold of such a vehicle can be understood by an inspection of Figure 4.41. The c.g. height of the sprung mass (inclusive of the tractor sprung mass) is plotted on the abscissa and the rollover threshold of the vehicle in g's is plotted on the ordinate. The change in the tank cross-section from an ellipse to a semi-rectangular profile increases the rollover threshold from .344 to .366 (an improvement of 4.6 percent), while the lowering of the tank bottom further raises the rollover threshold to .380 g. Hence, by the combined use of a more efficient tank cross-section and a drop-bottom side profile, the rollover threshold can be improved by as much as 10.5 percent for this vehicle.

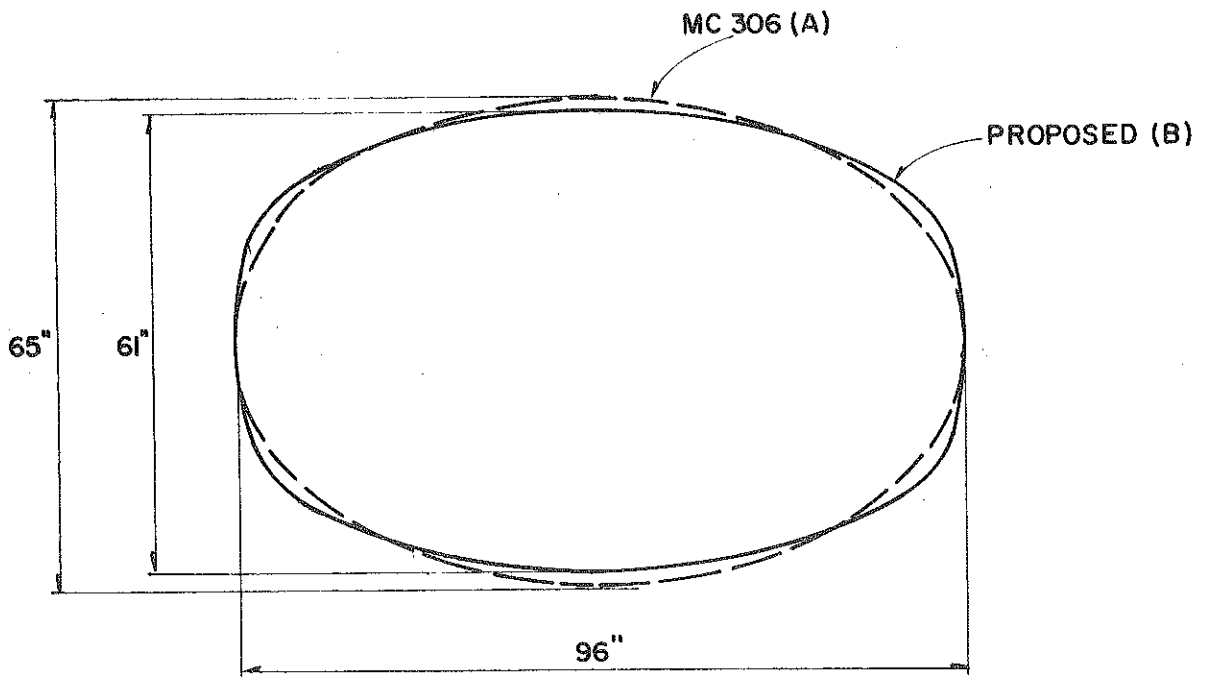

Figure 4.39. Comparison of the elliptical and semi-rectangular tank profiles.

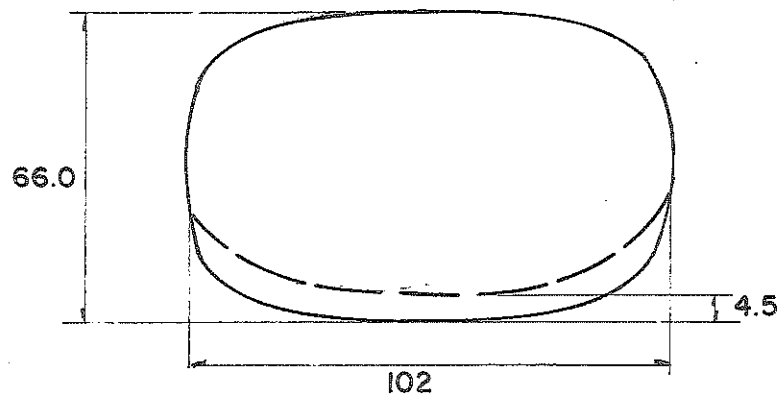
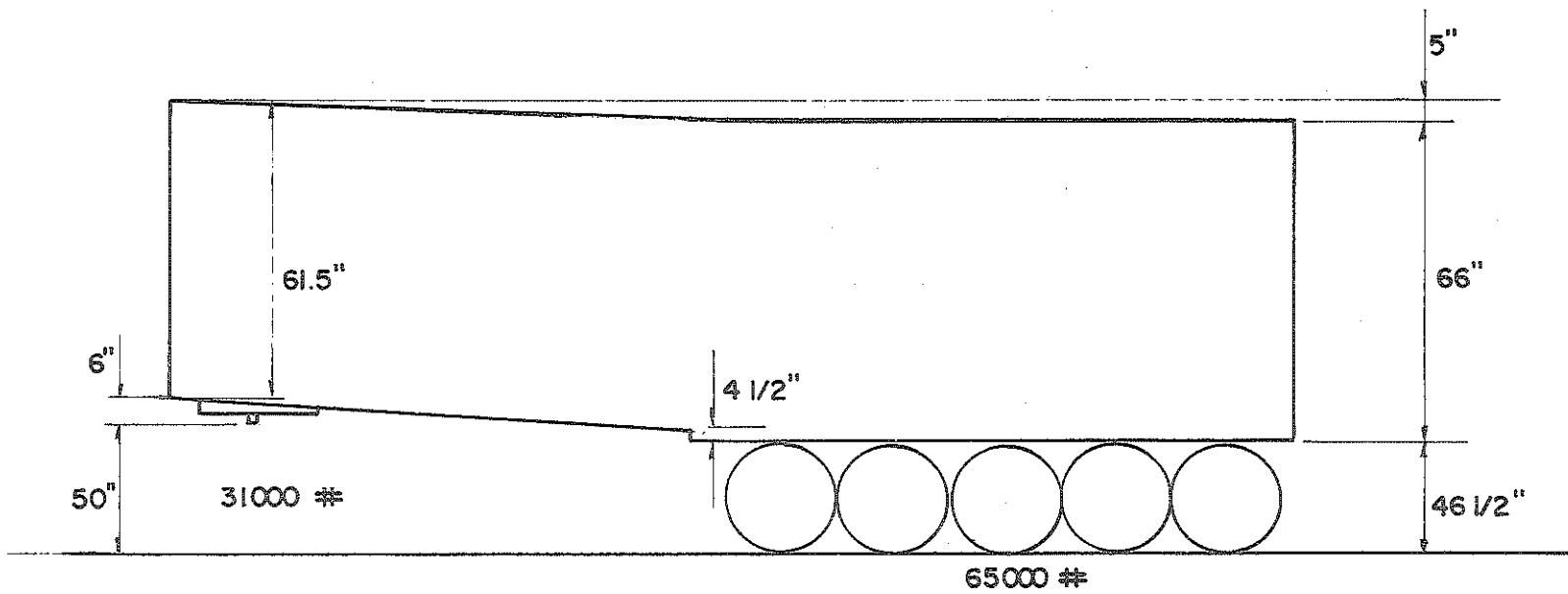
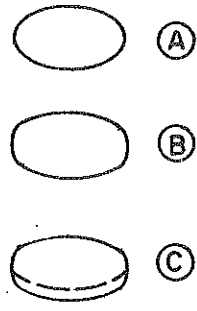

Figure 4.40. Drop-bottom combination for the tractor-semitrailer configuration #4a.



- (A) 96" Wide Elliptical Cross Section
- (B) 96" Wide Semirectangular Cross Section
- (C) 96" Wide Semirectangular Cross Section with Drop Bottom

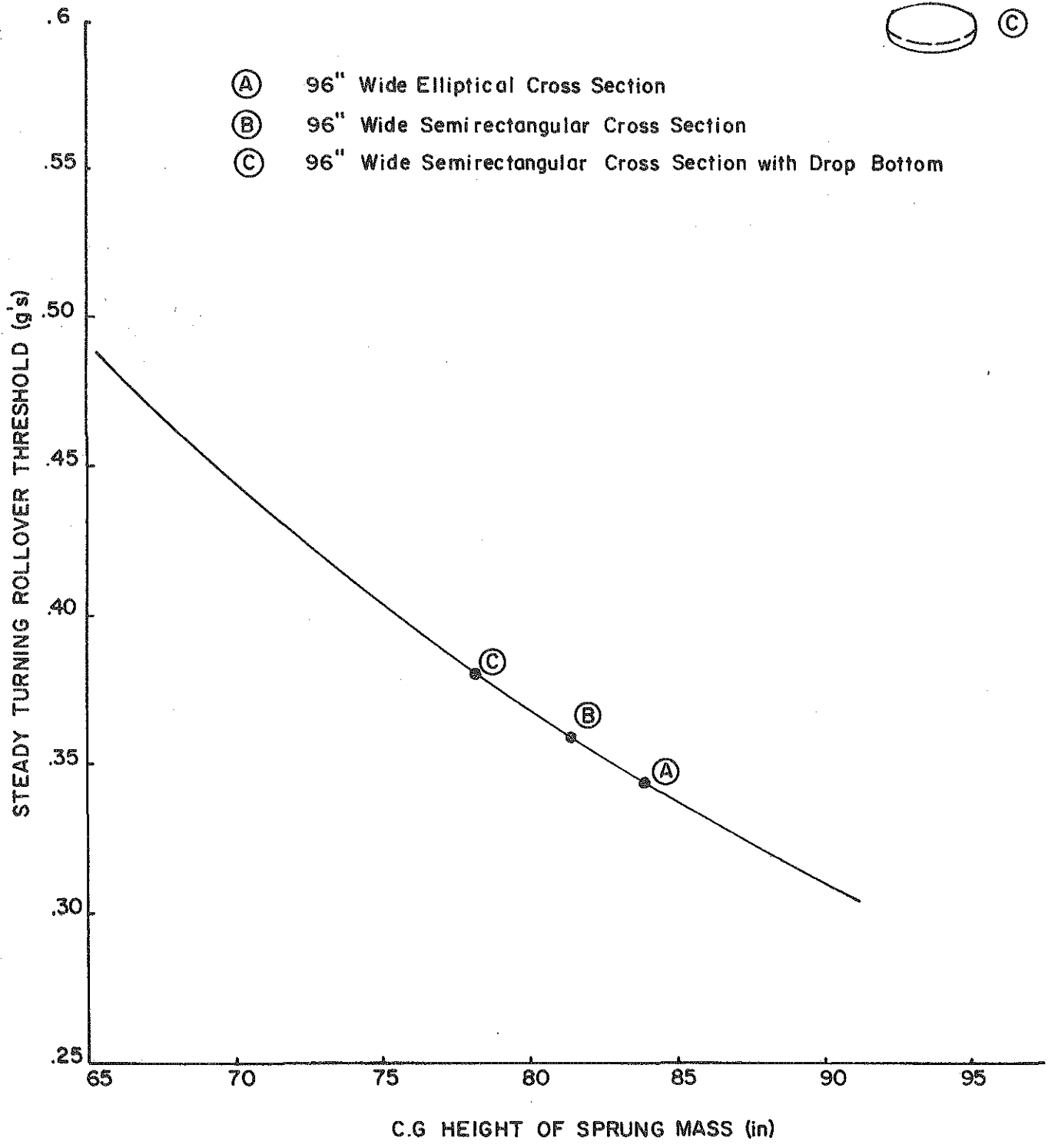

Figure 4.41. Influence of sprung mass c.g. height on the rollover threshold of configuration #4a.

4.2.3 Vehicle Track Width. Major improvements in the rollover threshold can be achieved by increasing the track width of a vehicle. When the track width of a gasoline tank vehicle is increased, the rollover threshold is improved through five distinct mechanisms, namely:

1. Increased track width implies a larger track-width-to-c.g.-height ratio and hence a higher rollover threshold.
2. The tank can be made wider, and hence the c.g. height of the tank lowered.
3. Larger track width permits the lateral distance between the suspension springs to be increased. The larger spring spacing, in turn, results in a higher suspension roll stiffness and therefore a higher rollover threshold.
4. The effect of suspension backlash on rollover threshold is reduced when the springs are spread further apart laterally, resulting in a small improvement in the rollover threshold.
5. The lateral spreading of spring centers permits a slight reduction in the height of the bottom of the tank shell.

Of course, the width of commercial vehicles is limited by both federal and state laws. The consideration of increased vehicle width is pursued here on the hypothesis that such a change holds so great a promise for improved roll stability that the basis for the existing legal constraints deserves reconsideration. The increase considered here has been limited to 6 inches (an increase from the conventional width of 96 inches to a width of 102 inches). This increase in overall width permits the lateral spring spacing to be increased from 38 inches to 44 inches.

Effect of Increased Tank Width on C.G. Height

Let us first look into the extent to which the shell height of a tank can be reduced by increasing the width of the tank. In Figure 4.42 the cross-sectional efficiency, n , is plotted as a function of the shell area (in the units of gallons per inch of tank length) for a 96-inch

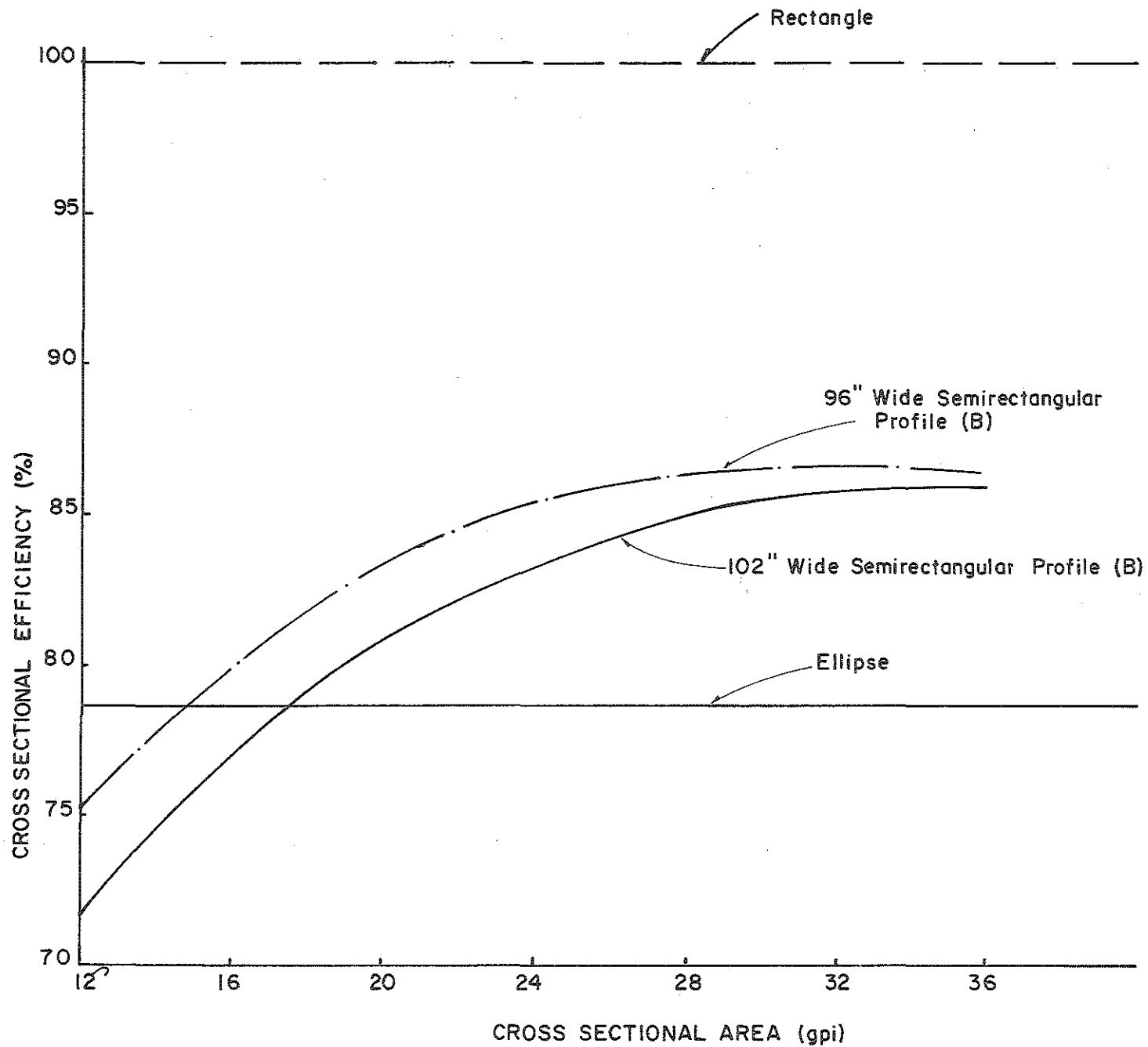

Figure 4.42. Cross-sectional efficiency as a function of tank cross-sectional area.

wide and a 102-inch wide profile. The tank cross-sectional efficiency of both the profiles is seen to fall rapidly when the cross-sectional area is reduced. The 102-inch-wide profile is increasingly less efficient than the 96-inch-wide profile when the shell cross-sectional area is reduced below 36 gpi. This lower efficiency of the 102-inch-wide profile means that, for small cross-sectional area tanks, the height of the 102-inch-wide tanks would not be significantly smaller than the height of the 96-inch-wide tanks. For example, for a cross-sectional area of 20 gpi, the 96-inch-wide profile has an efficiency of 83.3 percent, while the 102-inch-wide profile has an efficiency of 80.9 percent. Therefore, an increase in width from 96 inches to 102 inches (an increase of 6.25 percent) results in a decrease in tank height from 57.8 inches to 56 inches, or 3 percent. The same calculation, when performed for a 30 gpi cross-sectional area, shows a larger reduction in tank shell height—from 83.5 inches to 79.5 inches, or 4.8 percent. Therefore, the larger capacity tank vehicles accrue the maximum improvement in rollover threshold from a widening of the tank shell.

The net effect of all the vehicle height-influencing factors that have been considered so far (improved tank profiles, lowering of the tank bottom, and widening of the tank shell) are illustrated in Figure 4.43 for five of the tractor-semitrailer configurations. The reduction in overall shell height and the c.g. height of the vehicle is seen to be the maximum for the largest capacity tanker. The overall reduction in c.g. height ranges from 6.25 percent for the 8,800-gallon tanker to 8.7 percent for the 13,200-gallon capacity tanker.

Effect of Track Width on Rollover Threshold

Having looked at the influence of vehicle width on the height of the tank vehicle's center of gravity, we now expand the discussion to establish the net influence of track width on the overall rollover threshold level. We shall consider two cases.

1. The case in which the track width of the trailer axles alone are increased to 102 inches, while the track width of the tractor is retained at 96 inches, and

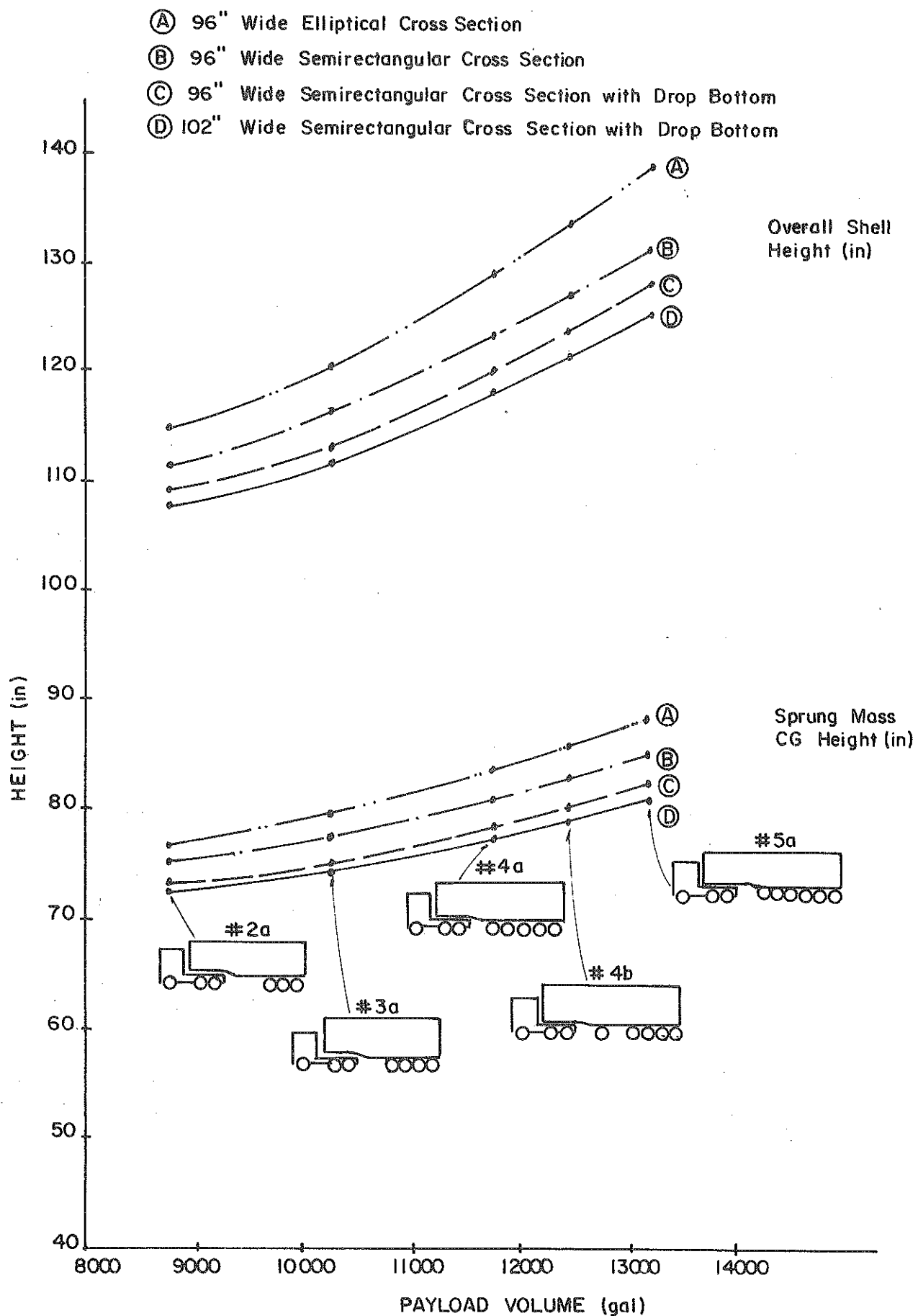

Figure 4.43. The influence of tank profile and tank width on the heights of five of the candidate tractor-semitrailer configurations.

2. the track widths of both the tractor and the trailer are increased to 102 inches.

The rollover threshold calculations were performed using the suspension properties which are listed in Table 4.4. The suspension backlash was set to zero for both the tractor and trailer suspension springs.

Table 4.4

	Spring Rate in Compression (Per Spring) lb/in	Spring Rate in Tension (Per Spring) lb/in
Tractor Front Axle	1500	1500
Tractor Rear Axles	6000	4000
Trailer Axles	14000	4000

The influence of increased track width and the use of more efficient tank profiles on the rollover thresholds of five of the candidate tractor-semitrailer combinations are illustrated in Figure 4.44. The rollover thresholds of the vehicles for each of the design changes considered are connected by straight-line segments. This figure serves to illustrate graphically the contrast in rollover threshold changes deriving from the width change as well as the changes in tank section layout.

At the bottom of the figure is seen a 96-inch-wide vehicle having an elliptical cross-section. The first improvement that is considered beyond this baseline case is that of adopting the more efficient semi-rectangular profile. Referring to the lines marked A and B in Figure 4.44, we note, as stated earlier, that the higher capacity tankers benefit the most by the adoption of a semi-rectangular profile. The 8,800-gallon tanker shows an improvement in rollover threshold of only 2.4 percent, while the 13,200-gallon tanker shows a much larger improvement of 6.2 percent.

- Ⓐ 96" Wide Elliptical Cross Section
- Ⓑ 96" Wide Semirectangular Cross Section
- Ⓒ 96" Wide Semirectangular Cross Section with Drop Bottom
- Ⓓ 102" Wide Semirectangular Cross Section with Drop Bottom and 96" Wide Tractor
- Ⓔ 102" Wide Semirectangular Cross Section with Drop Bottom and 102" Wide Tractor

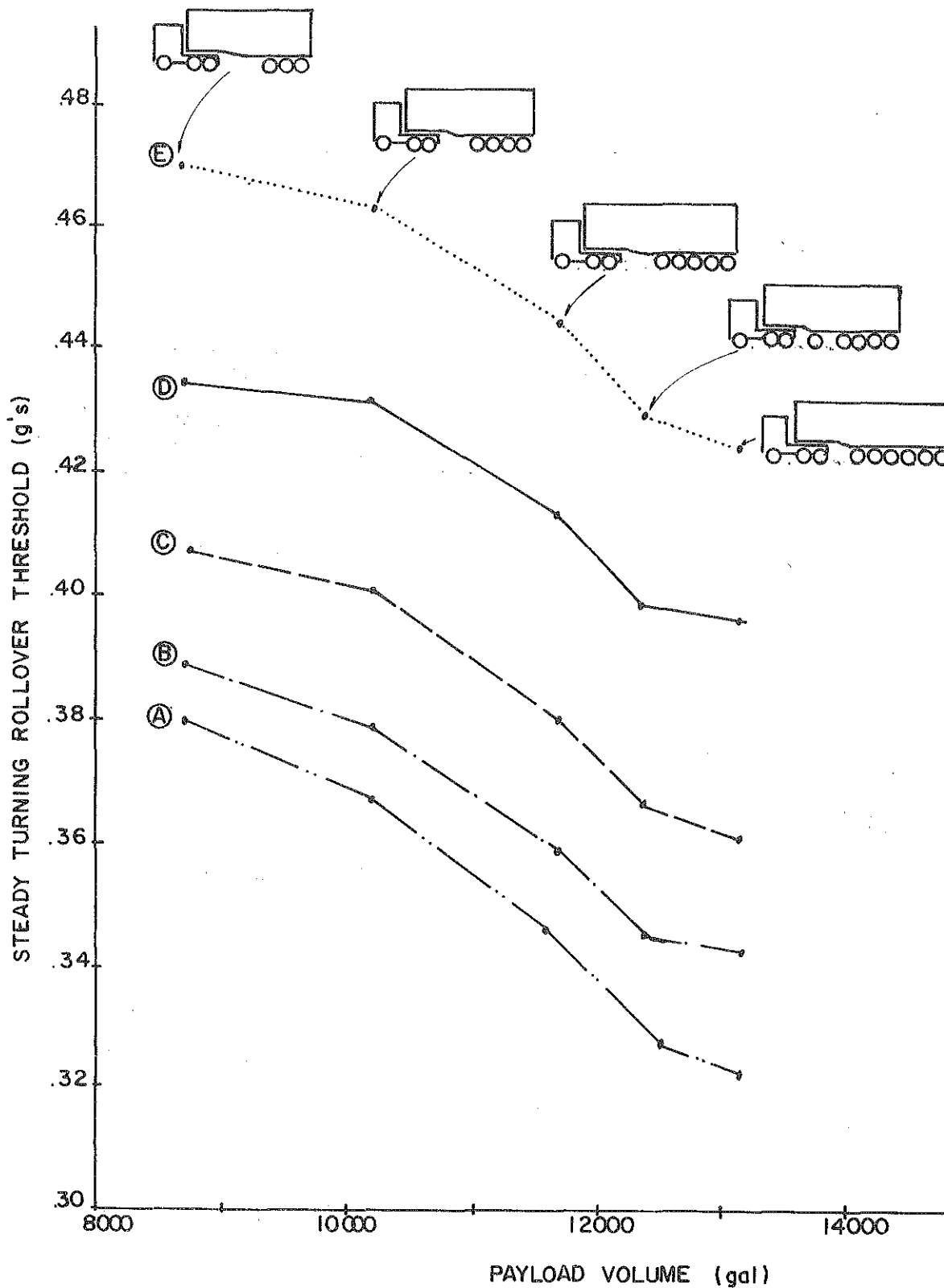

Figure 4.44. Influence of track width and tank cross-sectional geometry on the rollover threshold of five of the candidate tractor-semitrailer configurations.

Providing a drop-section in the side-view profile of the tank (line C in Figure 4.44) brings approximately the same amount of improvement in all of the five vehicles. The 4.5-inch drop-section produces a 4.6 percent increase in rollover threshold for the 8,800-gallon tanker and a 5.3 percent increase for the 13,200-gallon vehicle.

The next variation that was considered is that of widening the track width of the trailer to 102 inches. This increase in the trailer's track width is accompanied by the widening of the tank shell to 102 inches and an increase in the lateral spacing of trailer suspension springs from 38 inches to 44 inches. On comparing the line marked D with line C, we note that larger capacity tankers are the ones that benefit the most from the widening of the trailer's track width. The 8,800-gallon capacity tanker shows an improvement in rollover threshold from 0.406 g to 0.433 g (6.7 percent), while the 13,200-gallon tanker shows a larger improvement from 0.36 g to 0.395 g (9.7 percent). The large number of trailer axles which are present on the larger capacity vehicles produce the dominant portion of the roll-restraining moment. Hence, when the trailer axles are widened, the improvement in the rollover threshold of the larger capacity vehicles is more significant than that of the smaller capacity vehicles.

The last design modification that was considered was that of widening the track width of the tractor, as well, to 102 inches. The rollover threshold of the 102-inch-wide tractor/102-inch-wide trailer combinations are marked by line E in Figure 4.44. Widening the track width of the tractor to 102 inches is seen to have a more significant impact on the rollover threshold of the 8,800-gallon tanker as compared to the 13,200-gallon tanker. The significance of this change is thus sensitive to vehicle size in a manner which is the opposite of that which was observed when the track widths of the trailer axles were widened. By way of explanation, we observe that the tractor axles support a larger percentage of the total load carried by the smaller capacity vehicles as compared to the larger vehicles, and hence play a more significant role in determining the rollover threshold of the smaller capacity vehicles. The 8,800-gallon capacity tanker shows an improvement of 10.6 percent in rollover threshold, while the 13,200-gallon capacity tanker shows an improvement of only 6.8 percent.

If the cumulative effect of all the modifications that have been considered are now evaluated, we note that the 8,800-gallon capacity tanker shows a total improvement of 23 percent in rollover threshold, while the 13,200-gallon tanker shows an improvement of 31 percent over the respective levels of rollover threshold prevailing in the baseline configurations.

4.2.4 Suspension Properties. The nominal influence of changes in the c.g. height and track width of a vehicle and the rollover threshold are presumably obvious even to a layman. The influence of suspension stiffness variations on the rollover threshold of a multi-axled vehicle is, on the other hand, not so obvious. A discussion which is aimed at gaining a basic understanding of how suspension properties can affect the rollover threshold of a vehicle is included in Appendix F. In this section, computations using the static roll plane model will be presented, as they describe the effects of suspension stiffness and suspension lash on the rollover threshold of two of the candidate vehicles.

Leaf spring suspensions exhibit highly nonlinear force-deflection characteristics. The tensile and compression portion of the force-deflection characteristics of a leaf suspension spring, which is typical of tanker applications, is shown in Figure 4.45. With reference to Figure 4.45, we note that when the direction of force application changes from compression to tension, the spring goes through a dead zone or lash space of height, δ . The tensile spring rate, K_{st} , of multi-leaf springs is, in general, lower than the compression rate, K_{sc} , due to the fact that the topmost leaf alone tends to deflect under a tensile force. The representation of the suspension spring properties in the roll plane model is shown on the right-hand side of Figure 4.45.

Suspension Stiffness

We shall first discuss the influence of the trailer suspension stiffness parameters, K_{sc} and K_{st} , on the rollover threshold of two of the tractor-semitrailer configurations—#3a and #5a. The calculations were performed assuming a zero value for the lash space, δ , in the tractor and trailer suspension springs. The influence of suspension lash will be discussed later in this section. The tractor suspension properties were characterized by the following parameters:

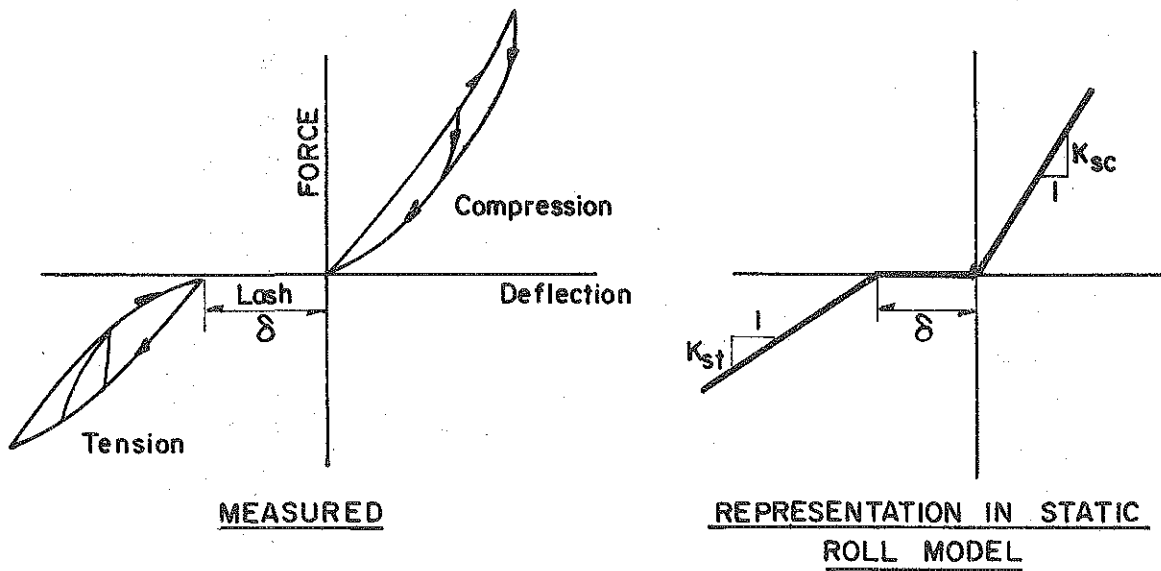

Figure 4.45. Force-deflection characteristics of leaf spring suspensions.

- spring rate of tractor front suspensions = 1500 lb/in/spring
- compression rate of tractor rear suspension springs
 $K_{sc} = 6000 \text{ lb/in/spring}$
- tensile rate of tractor rear suspension springs
 $K_{st} = 4000 \text{ lb/in/spring}$

During the parameter variation study, the trailer suspension spring rate in compression, K_{sc} , was varied from 6000 to 14,000 lb/in, and the tensile spring rate, K_{st} , from 4000 to 14,000 lb/in. A value of 96 inches was used for the track width of the tractor and the track width of the trailer was set at 102 inches. For the entire range of stiffness variations which were considered, the trailer tires achieved a "lift-off" condition at a lower level of lateral acceleration than was the case for the tires on the tractor rear axles. The rollover threshold of the vehicle was therefore reached when the in-board tires on the tractor rear axles lifted off the ground.

In Figure 4.46a, the lateral acceleration levels at which (1) the tires on the trailer axles lift off the ground and (2) at which the vehicle rolls over are plotted as a function of the trailer's spring rate in tension, K_{st} , for tractor-semitrailer configuration #3a. The lateral acceleration levels are shown for four different values of K_{sc} , namely, 6,000, 8,000, 12,000, and 14,000 lb/in. It is interesting to note that increases in both K_{sc} and K_{st} have a negligible effect on the rollover threshold of the vehicle. Increases in K_{sc} and K_{st} merely reduce the lateral acceleration level at which the trailer tires lift off the ground.

The sprung mass roll angle at which (1) the trailer tires lift off the ground and (2) at which the vehicle begins to rollover are plotted in Figure 4.46b for the same variations in the parameter values for K_{sc} and K_{st} . Increasing the trailer suspension spring rates reduces the indicated values of sprung mass roll angle at which the trailer tires lift off the ground, but has no significant effect either on the rollover threshold or the roll angle at which the vehicle begins to overturn.

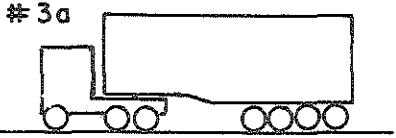

(a)

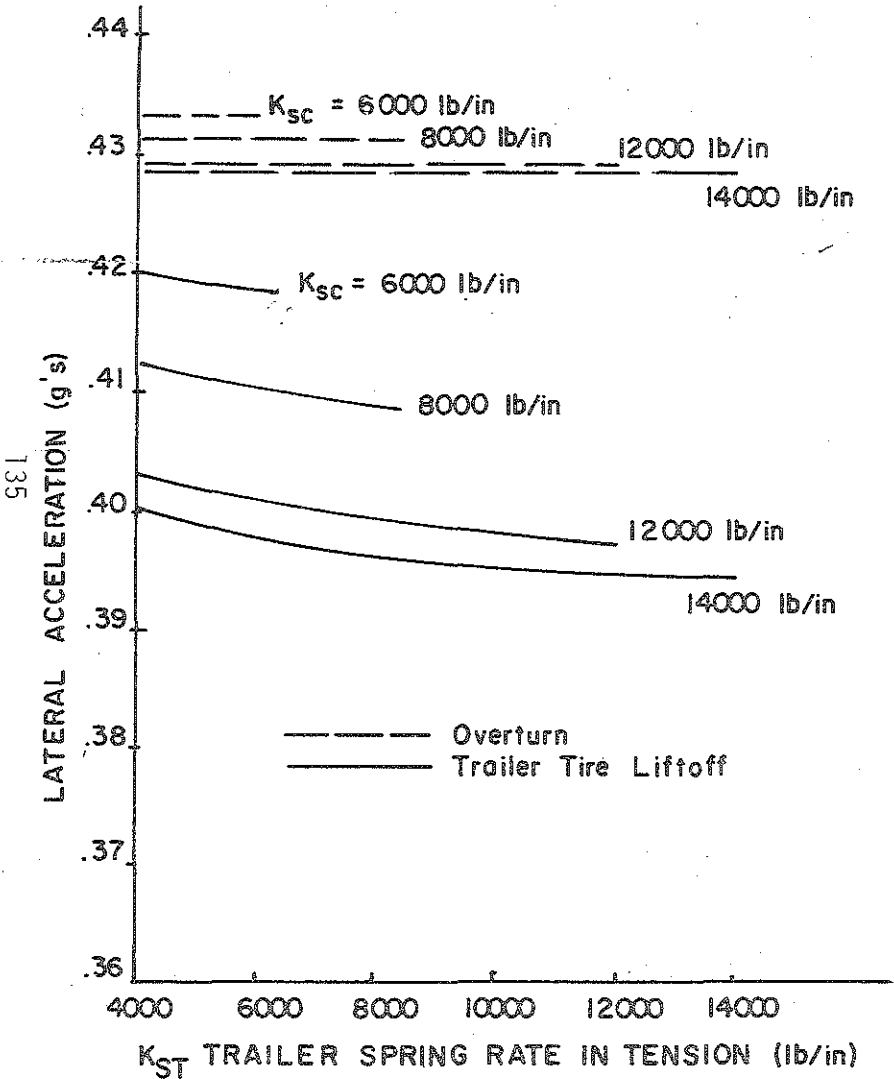

(b)

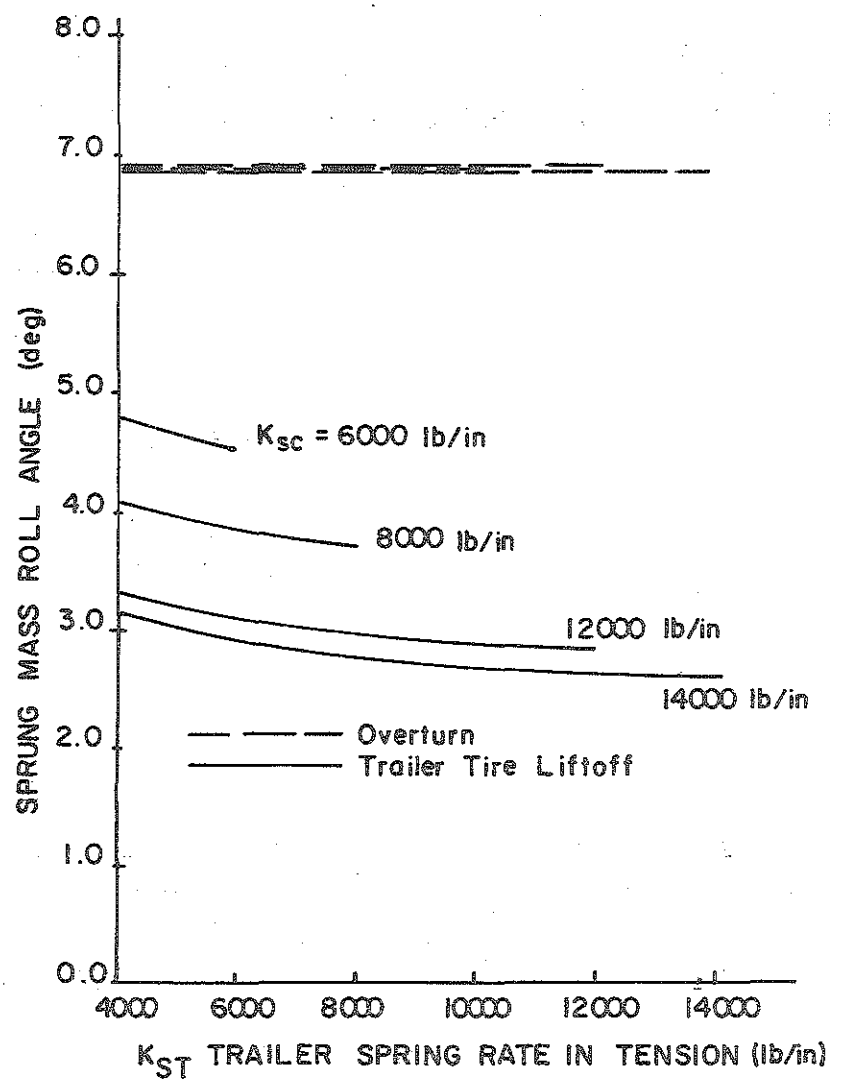

Figure 4.46. Influence of the stiffness of the trailer suspension system on the rollover threshold and sprung mass roll angle of configuration #3a.

The critical level of lateral acceleration and the critical sprung mass roll angles are shown in Figure 4.47a and 4.47b, respectively, for one of the larger tractor-semitrailer combinations—configuration #5a. On inspecting Figure 4.47a, we note that the lateral acceleration which corresponds to the rollover threshold is not significantly higher than the lateral acceleration at which the trailer tires lift off the ground. This is due to the fact that the six semitrailer axles which are present on configuration #5a contribute most of the roll-resisting moment. The additional roll-resisting moment that the tractor axles can generate, beyond the point at which the tires on one side of the trailer axles lift off the ground, is therefore very small.

Suspension Lash

The presence of lash in the tractor and trailer suspensions makes the analysis of the roll behavior of articulated vehicles much more complex. Shown in Figure 4.48 is a plot of lateral acceleration versus sprung mass roll angle for the tractor-semitrailer configuration #3a. In this figure, the lateral acceleration/roll angle relationship is shown for five levels of trailer lash, ranging from 0.0 inch to 2.0 inches. The tractor suspension parameters which were used in generating this plot were the same as the ones used in Figures 4.46 and 4.47, except that, in this case, the tractor rear suspension is assumed to have a lash of 1.5 inches. The trailer suspension stiffnesses were set at $K_{sc} = 14,000$ lb/in and $K_{st} = 4,000$ lb/in.

In Figure 4.48, let us first consider the baseline case for which there is no lash in the trailer suspension. Starting with zero roll angle, and upon increasing the level of lateral acceleration, the plot follows the trajectory OABCDE. For low levels of lateral acceleration, the sprung mass roll angle is defined by points which lie along the line OA. At point A, the suspension springs on one side of the trailer go from compression to tension. Since the tensile spring rate, K_{st} , is lower than the compression rate, K_{sc} , the line AB is less steep than OA. At point B, the tires on one side of the trailer are completely lifted off the ground (while all the tires on the tractor's front and rear axles

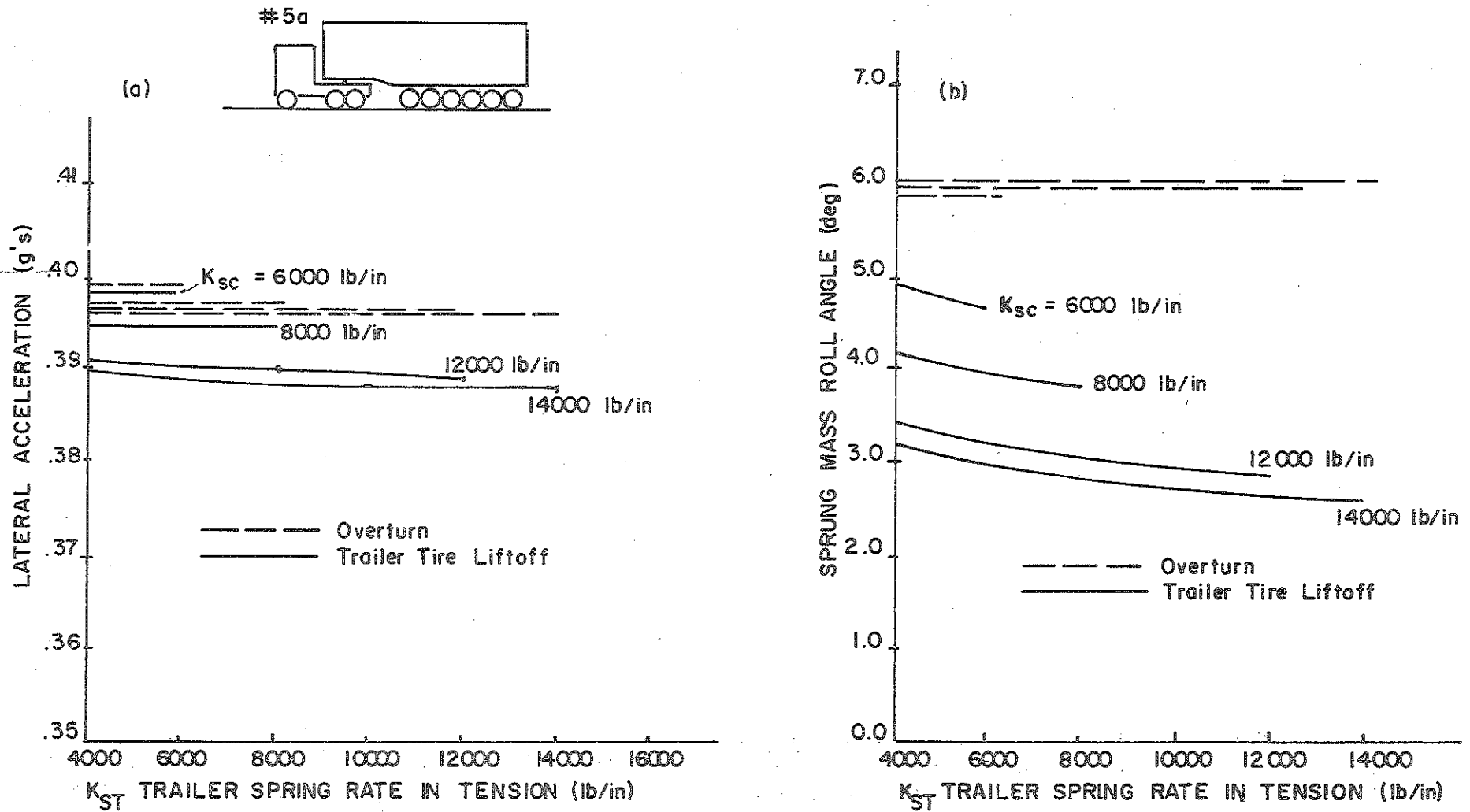
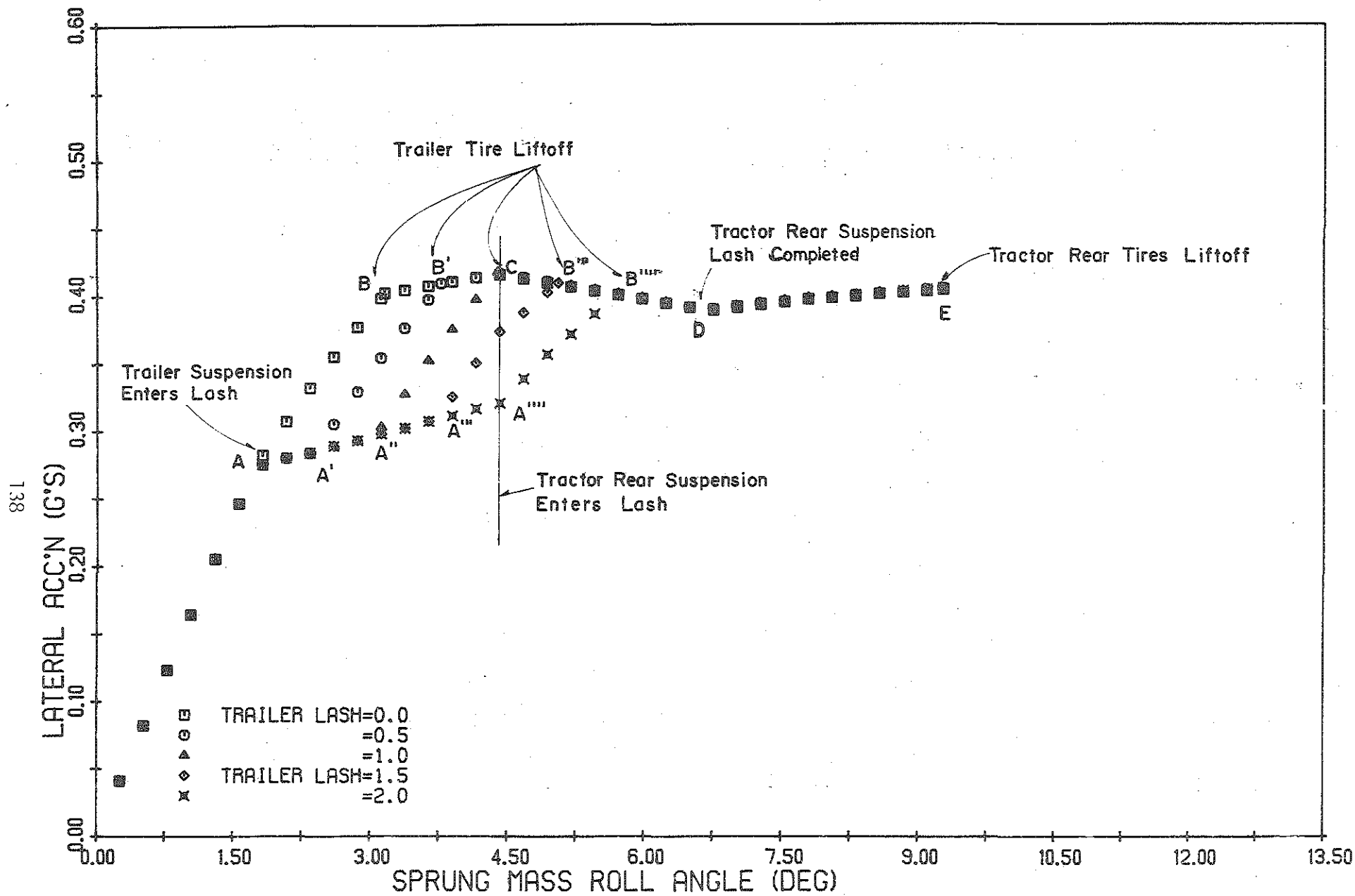

Figure 4.47. Influence of the stiffness of trailer suspension systems on the rollover threshold and sprung mass roll angle of configuration #5a.



TRACTOR-SEMI CONFIG #3A, INFLUENCE OF LASH, KSC=14K, KST=4K. TRACTOR LASH=1.5"

Figure 4.48

are still on the ground). Since the roll stiffnesses of the tractor's suspension are small compared to the trailer suspensions, the slope of the lateral acceleration versus roll angle plot is significantly reduced beyond the point of trailer tire lift off—point B. At point C, the suspension springs on one side of the tractor rear axle enter the lash zone and the lateral acceleration needed to maintain roll equilibrium reduces along the line CD. The tractor's rear suspensions complete their travel through the lash and go into tension at point D. At point E, the tires on one side of the tractor's rear axle (as well as those on the trailer axles) are completely off the ground, while both the tires on the tractor front axle are still resting on the ground. Beyond this point, stable roll equilibrium does not exist due to the fact that the stiffness of the tractor front suspension is not sufficient to counteract the overturning moment produced by the rolling of the vehicle. In an actual steady turning maneuver, the roll response follows the line, OABC, beyond which any increase in lateral acceleration level produces rollover. The rollover threshold of the vehicle, with no trailer lash, is therefore defined by point C.

Let us now consider the influence of lash in the trailer suspension springs. The roll response of a vehicle with 1/2-inch lash in the trailer suspension springs is given by the trajectory, OAA'B'CDE. The trailer suspension springs enter the lash at point A. The segment AA' represents travel of the trailer suspension springs through the lash. At A', the trailer suspension springs go into tension and start applying a lift force to the trailer axles. The tires on one side of the trailer axles lose road contact at point B'. Beyond the point of lift-off of the trailer tires, the roll response follows the same trajectory that was followed for the case with no trailer lash. We notice that, for this particular combination of vehicle parameters, the presence of 1/2-inch lash does not affect the maximum lateral acceleration level (point C) that can be achieved. For higher levels of trailer lash, such as 1.5 inches and 2.0 inches, the peak lateral acceleration is reduced from C to B''' and B''', respectively. It can therefore be stated that, for this particular combination of vehicle parameters, when the trailer lash exceeds one inch, it has a degrading effect on the rollover threshold of the vehicle.

The influence of lash in the trailer suspension on the rollover threshold of the tractor-semitrailer of configuration #3a is plotted in Figure 4.49. The results are presented for two sets of tractor suspension parameters. One set represents a "light-duty tractor" that is typical of line-haul highway vehicles involving 80,000-lb gcw vehicle combinations. The other set pertains to a heavy-duty-type tractor such as is typical of tractors used for hauling higher gross weight loads in Michigan. The parameters which represent the suspension properties of each of two types of tractors are included in Figure 4.49. It can be observed that higher levels of rollover threshold can be achieved by the use of a "heavy-duty-" type tractor.

Figure 4.49 indicates that the effect of tractor suspension lash on the rollover threshold of the vehicle is dependent upon the type of tractor to which the trailer is coupled. In the presence of a "light-duty tractor," the rollover threshold is degraded by lash in the trailer suspension. The extent to which the rollover threshold is degraded is dependent upon the compression rate (K_{sc}) of the trailer suspension. The higher the compression rate of the trailer suspension, the less sensitive the vehicle is to the presence of lash in the trailer suspensions.

Due to the peculiar manner in which the rear suspension of the heavy-duty tractor interacts with the trailer suspension, the rollover threshold can be seen to increase with an increase in trailer suspension lash for a trailer suspension stiffness (K_{sc}) of 6,000 lb/in. Trailer lash is seen to have a small degrading effect on the rollover threshold of the vehicle for the other two trailer suspension spring compression rates that were considered.

It can be observed that, for a trailer equipped with springs which have a compression rate, K_{sc} , of 14,000 lb/in and a lash of 0.5 inch, the rollover threshold of the vehicle can be increased from 0.41 g to 0.426 g (an increase of 2.5 percent) by the adoption of a heavy-duty tractor.

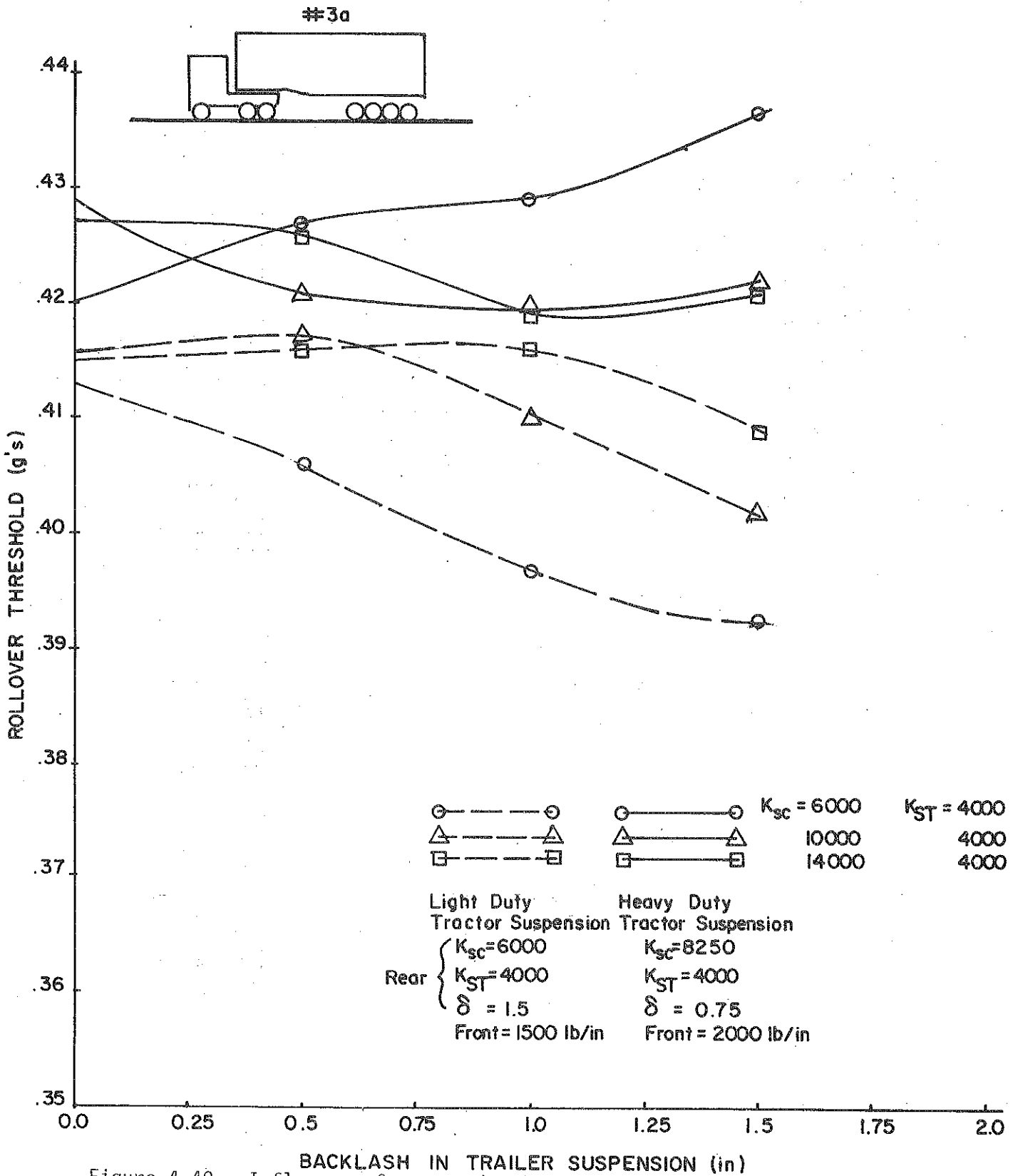

Figure 4.49. Influence of suspension backlash on the rollover threshold of tractor-semitrailer configuration #3a.

The influence of suspension lash on the rollover threshold of the tractor-semitrailer configuration #5a is shown in Figure 4.50. The comments made in connection with Figure 4.49 hold true for this vehicle as well.

4.3 The Influence of Sloshing Fluid Loads

One of the major variables in the operation of a bulk liquid transport vehicle that can affect its dynamic rollover behavior is the presence of unrestrained liquid due to partial filling of compartments. A compartment that is filled to anything less than its full capacity allows the liquid to move from side to side, producing the so-called "slosh" load condition. The lateral shift of the cargo's center of gravity in a maneuver is of safety concern because it reduces the vehicle's rollover threshold. In addition, the sloshing load may move out of phase with the vehicle's lateral motions in such a way that other degrading effects of slosh on dynamic behavior may also occur, further reducing the vehicle's rollover threshold.

4.3.1 The Dynamics of Slosh. The motions of an unrestrained liquid in a tank vehicle can be quite complex and can depend upon the tank size and geometry, the mass and viscosity of the moving liquid and the maneuver being performed. The mechanisms of slosh are most readily described in simple steady-state cornering, although it is in transient maneuvers that the most exaggerated fluid displacements take place.

Steady-state cornering: When a slosh-loaded tanker is performing a steady-state turn, the liquid responds to lateral acceleration by displacing laterally, keeping its free surface perpendicular to the combined forces of gravity and lateral acceleration. Figure 4.51a illustrates the position of a partial liquid load in a circular tank which is being subjected to a steady-state cornering maneuver. The mass center of the liquid moves on an arc, the center of which is at the center of the circular tank. In effect, the shift of the liquid produces forces on the vehicle as if the mass of the load was located at the center of the tank.

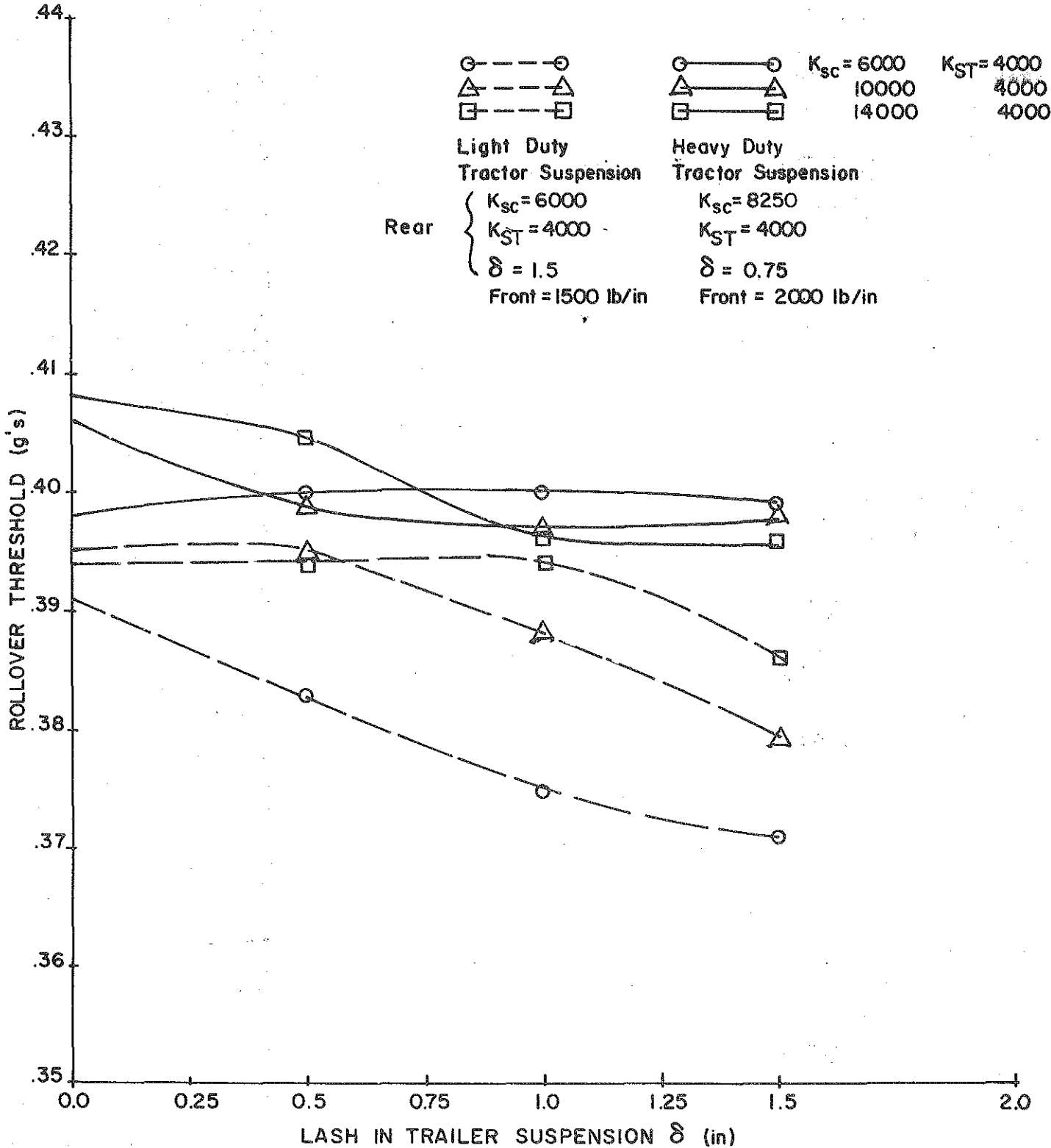
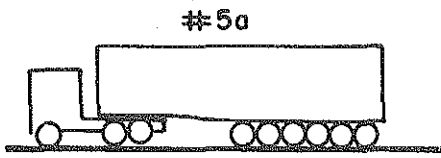

Figure 4.50. Influence of suspension backlash on the rollover threshold of tractor-semitrailer configuration #5a.

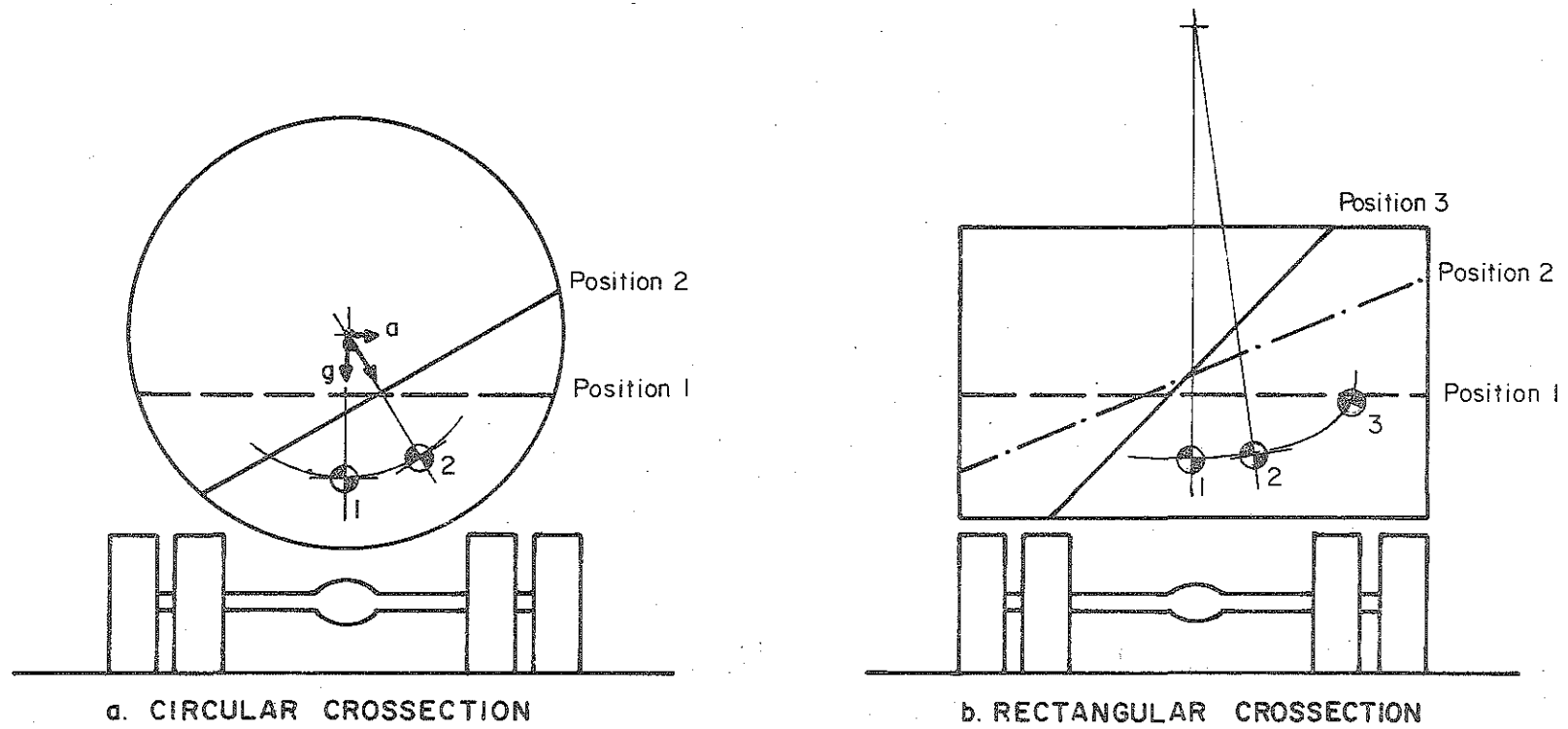

Figure 4.51. Illustration of liquid position in steady-state cornering with a circular (a) and rectangular (b) cross-section tanker.

With more complex tank shapes, even the steady-state behavior becomes somewhat difficult to analyze. In particular, with unusual tank shapes it becomes more difficult to describe the motion of the liquid's center of mass as a function of lateral acceleration. As a contrast to the circular tank, Figure 4.51b illustrates the behavior of liquid in a rectangular tank. At low lateral accelerations, the liquid movement is primarily lateral, centered at a point well above the tank center. Hence its effect is similar to having a very high mass center. With increasing lateral acceleration, the mass center follows a somewhat elliptical path.

While the circular tank results in a vehicle with a higher load center, efforts to reduce the load center by widening a tank can be expected to increase vehicle sensitivity to slosh-degradation of the rollover threshold. The effect is illustrated by the plot in Figure 4.52 taken from Strandberg [9] showing rollover threshold versus percent load. For a circular tank, increasing load lowers the threshold continuously, with the minimum rollover threshold occurring at full load. For a vehicle outfitted with a rectangular tank, higher levels of rollover threshold occur when the tank is either empty or full, although at intermediate load conditions the rollover threshold is severely depressed due to the greater degree of lateral motion possible for the unrestrained liquid. Thus, for fuel transport vehicles having a more or less rectangular tank form, rather than circular, slosh loading is seen to increase the rollover risks even beyond that of the fully loaded vehicle.

Transient maneuvers: In transient maneuvers such as an abrupt evasive steering maneuver or a rapid lane change, slosh loads introduce the added dimension of dynamic effects. With a sudden steering input, the rapid imposition of lateral acceleration will cause the fluid to displace to one side with an under-damped (overshooting) type of behavior. When represented as a simple undamped pendulum, the response of the fluid mass to a step input of acceleration would be seen to displace to an amplitude which is approximately twice the level of the steady-state amplitude. In a lane-change maneuver in which the acceleration goes

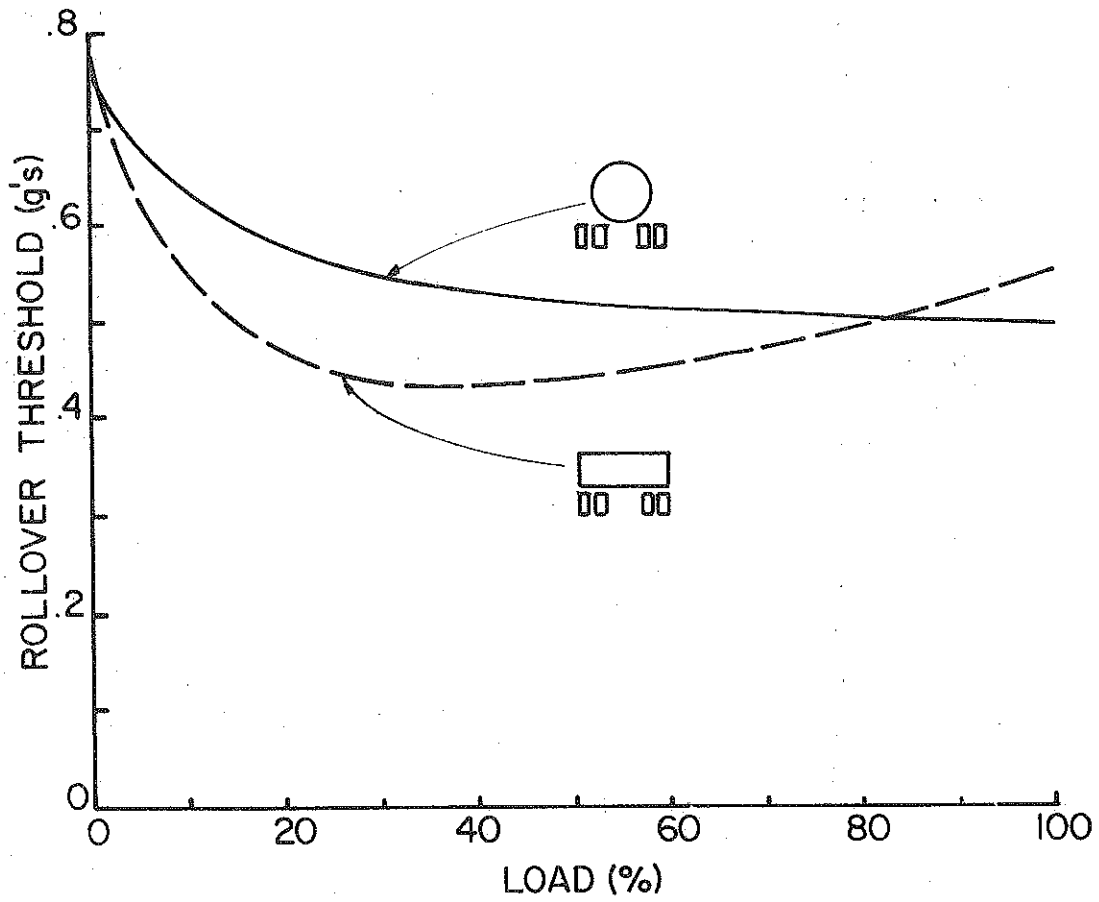

Figure 4.52. Rollover threshold as a function of load with an unrestrained liquid.

first in one direction and then the other, an even more exaggerated response amplitude can be produced.

In general, the degree to which the dynamic mode is excited depends on the timing of the maneuver. Depending on the liquid level and cross-sectional size of the tank, the unrestrained liquid will have a natural frequency of oscillation. For a half-filled, 8-foot-wide tanker, this frequency is approximately 0.5 Hz (cycles/sec). Studies of driver steering behavior [10] have shown that in a demanding steering task (tracking with a limited sight distance), the spectral density of the driver steering input can have a significant magnitude at this frequency, as shown in Figure 4.53. Also, the two-second lane change used by HSRI [2] as a typical evasive maneuver for evaluating tankers, constitutes a lateral acceleration input closely matched to the fluid frequency. Hence it must be concluded that dynamic slosh motions can be readily excited on a tanker, especially in the course of evasive maneuvers such as a lane change.

4.3.2 Fluid Slosh as a Mechanism Reducing the Rollover Threshold of Michigan Tankers. The partial loading of gasoline tankers in the State of Michigan represents a somewhat different set of conditions than those represented in Figures 4.51a and 4.51b. In general, the actual practice of partial loading appears to include cases in which only a few of the compartments may be filled while the others are empty, or in which one or more compartments are only partially filled (i.e., sloshing). With compartmentalization, an infinite variety of slosh conditions can be postulated.

In order to obtain a picture of the potential influence of slosh on the rollover threshold under the diversity of conditions representative of Michigan tanker operations, a computer simulation study was performed. Although analytical models are not available for the precise simulation of the dynamics of the slosh motions, a simulation method was available permitting a first-order approximation to be made. As described in the preceding sections, liquid slosh acts much like a pendulum, producing D'Alembert forces on the vehicle as if the liquid was located

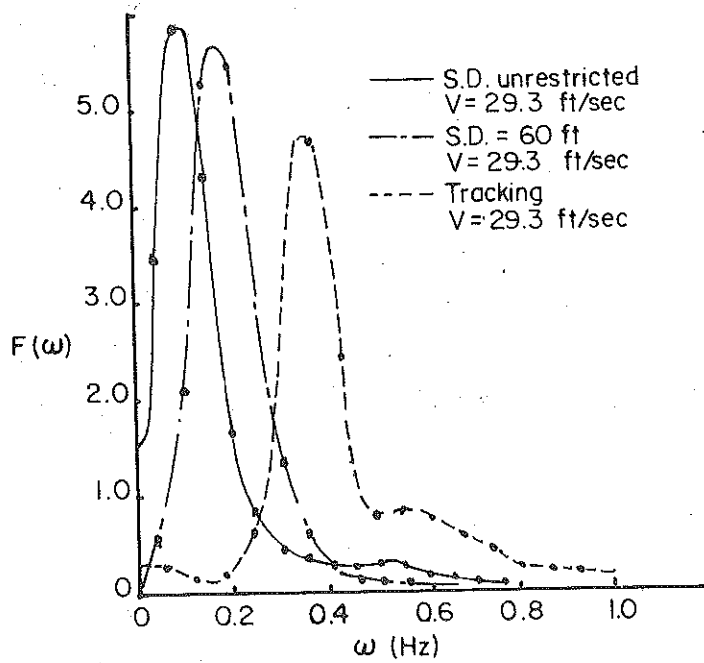

Figure 4.53. Typical normalized spectral density functions obtained from steering-wheel angle records.

at an elevated pivot point. An estimate of steady-state rollover threshold with an unrestrained liquid load was thus obtained using the static roll simulation model described in Section 4.1.3, locating the assumed slosh liquid mass at the height corresponding to the pendulum pivot point. The pivot point, in turn, is determined for a given tank shape by analytically or graphically determining the trajectory of motion for the sloshing mass center at each loading level.

Further, an estimate of the dynamic effect of slosh in a transient maneuver was obtained from the static model results by simply assuming that the slosh load will overshoot the equilibrium (steady-state) pendulum amplitude by 100 percent in a step-steer maneuver. In effect, this estimate is obtained by employing a pendulum pivot which is located at twice the elevation (with respect to the bottom of the tank) of the slosh-loaded liquid. (That is, for a given liquid load level, the static load center is first calculated and the pendulum center is located. Elevating the mass by placing it at the height of the "equivalent" pendulum center provides a representation of the steady-state slosh condition. Doubling the elevation is equivalent to the step-steer condition.)

This representation was used to explore slosh effect using the tank cross-sectional form proposed for the 13,200-gallon tanker configuration, #5a. Figure 4.54 shows the systematic effect of slosh on the step-steer rollover limit as the total load is varied. The top curve represents the threshold with no slosh (i.e., when variously-sized compartments are filled to achieve the desired load condition). The lower curve illustrates the effect on a two-compartment tanker as the load is increased by adding fluid to one compartment until it is full and then to the second. With the first addition of unrestrained liquid, the rollover threshold diminishes rapidly, then rises again to the no-slosh limit as the compartment becomes full. From the 50-percent load condition, adding liquid to the second compartment again rapidly diminishes the threshold until we approach the no-slosh, fully loaded condition.

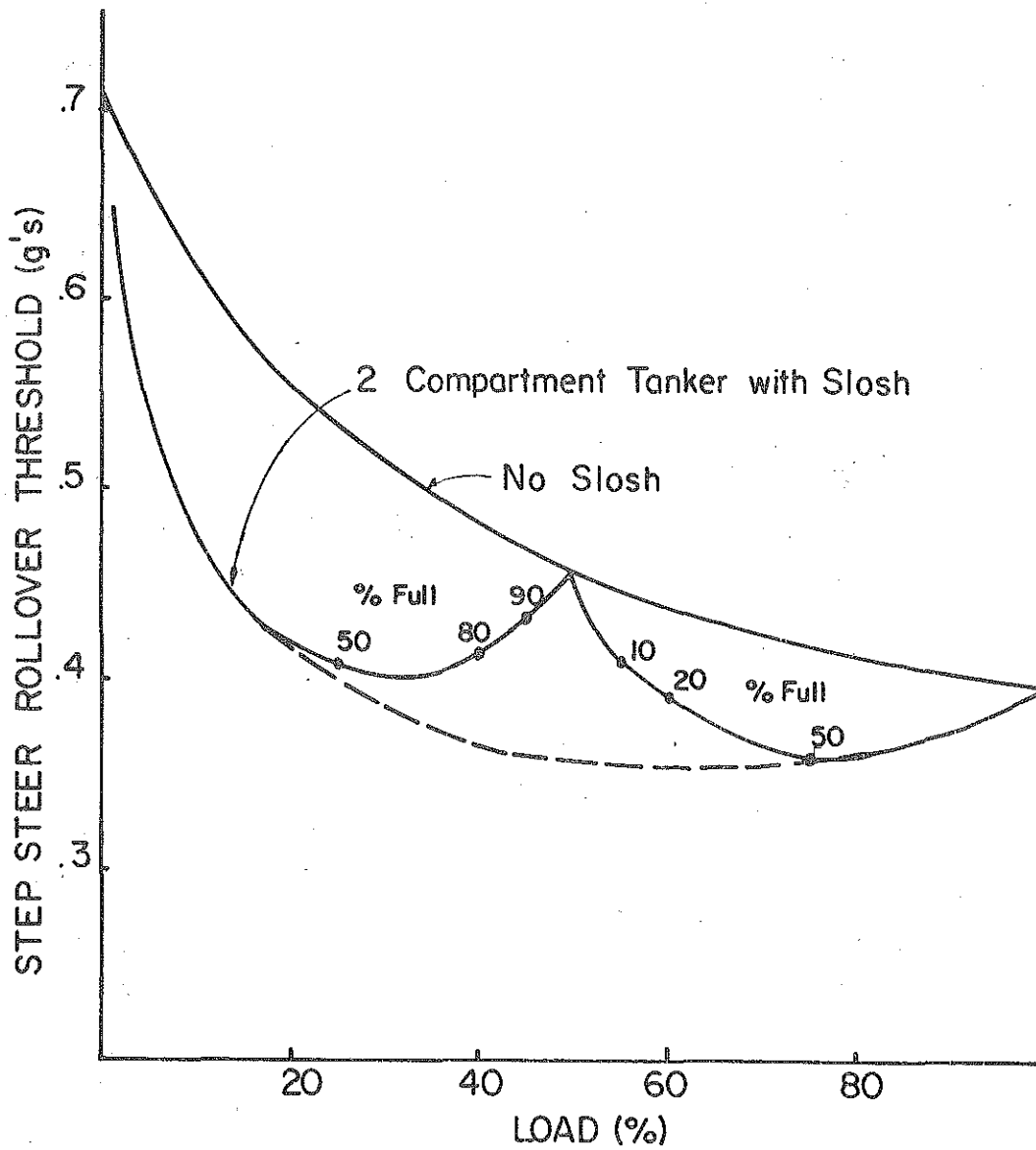

Figure 4.54. Effect of slosh load on rollover threshold for a two-compartment tanker.

If, on the other hand, we considered a tanker having four equal compartments—one full, two half-full, and one empty—the threshold would fall on the dotted line at the 50-percent load condition. Other compartmentalization patterns could result in rollover thresholds at any other point on the dotted line. Thus the lower (dotted) curve must be taken as the potential lower limit of rollover threshold for a 50-percent slosh condition. Note, too, how rapidly the threshold changes with just a nominal amount of fill or underfill in a compartment.

From a systematic study of the way in which diverse loading combinations affect rollover threshold, certain sensitivities have become evident. Specifically, the rollover threshold is seen to be most sensitive to the amount of total load carried and to the volume, V_{CS} , of the compartment(s) which have been loaded "in a slosh condition" as a fraction of the total tank volume, V_T . In this analysis the compartments that are in the slosh condition are defined as those which are loaded between 20 and 80 percent full (see, for example, Reference [9]).

The fraction V_{CS}/V_T has been found useful for illustrating the sensitivity of the rollover threshold to slosh even though it does not describe the actual quantity of fluid which is, in fact, sloshing within the involved compartment volume, V_{CS} . The fraction is explained as a useful descriptor of slosh because of two compensating mechanisms related to the volume of the sloshing fluid. Namely, we find that a lightly-filled compartment suffers large lateral displacements of a light sloshing mass while a mostly-full compartment involves the small lateral shifting of a heavy sloshing mass. Thus the absolute size of the slosh compartments, V_{CS} , determines the approximate magnitude of the roll-destabilizing forces that are developed. The result is that once a compartment is established as being in the 20-80 percent full range, a good first-order estimate of the proportional reduction in rollover threshold due to the sloshing liquid is obtained by the ratio V_{CS}/V_T .

Using the computer simulation to predict rollover threshold versus percent load for cases of constant values of V_{CS}/V_T , results shown in Figure 4.55 were produced representing the 13,200-gallon tanker. Vehicles having partial compartment loads falling outside of the 20 to 80 percent

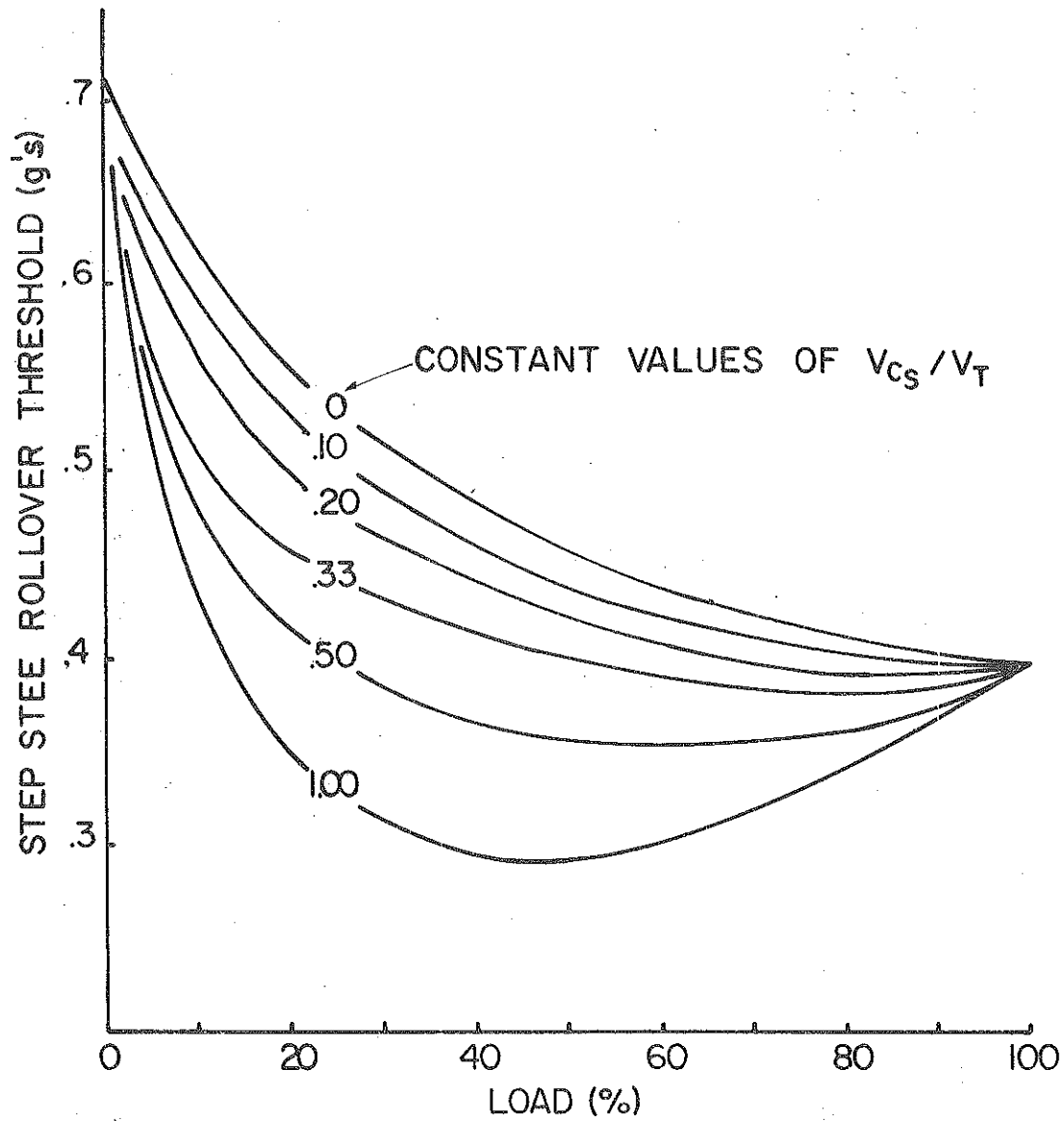

Figure 4.55. Rollover threshold as a function of load percentage and fractional slosh volume.

criterion were assumed to perform as with no slosh (that is, employing the upper curve in the previous figure, 4.54) and those within the 20-80 percent are assumed equivalent to the worst case condition (the dotted line in Figure 4.54).

Taking Figure 4.55 to be representative of the potential influence of slosh on tanker operations, we note that:

- 1) Operation at a partial load condition does not produce lower values of rollover threshold than that deriving from the 100-percent load condition so long as no more than 10-20 percent of the tanker volume is loaded in a slosh condition.
- 2) Operation with 50 percent or more of the tank volume in a slosh condition produces large reductions in rollover threshold over almost the total range of overall loads.

In Section 7, the computed effects of slosh on rollover threshold are combined with survey data describing the incidence of slosh loading in the field. A prediction is then made of the increment in risk which derives when gasoline tankers are permitted to operate with a representative incidence of partially filled compartments.

5.0 CONTAINMENT OF THE TRANSPORTED FLUID IN AN ACCIDENT

The loss of fluid product in tanker accidents derives primarily from tank failures induced in rollover impacts. Indeed, Michigan data show that in a recent two-year period, only one in 25 product spill incidents occurred due to a non-rollover accident. In this project, a review was made of tanker accidents reported by the Michigan Fire Marshall's Office to identify mechanisms of tank failure occurring in rollover accidents. Upon observing that the most common failure mechanism involved the manhole covers which are mounted on the top of each tank compartment, a set of experiments was conducted to establish the impact pressure conditions to which manhole covers are subjected in a rollover.

5.1 Review of Tank Failure Data

Using the State of Michigan Fire Marshall's Incident Reports for 1977 and 1978, 33 accidents were identified for study in which the tanker overturned with the possibility of damage to the tank. Selection criteria included (1) vehicle overturn, (2) capacity in excess of 5000 gallons, (3) a single-trailer articulated vehicle or a "doubles" vehicle. Straight, local delivery vehicles were not included.

Attempts were made to contact each company by telephone to seek permission to see the vehicle. Of these attempts, seven vehicles were available and documented, 20 vehicles were not available but company personnel were interviewed, and in six cases no interview or contact was possible. Of the 20 contacted, the majority of the vehicles had been repaired and were back on the road. In a few instances, the vehicles had been sold for scrap (retired from service or melted down in the fire) and no longer existed. The data on the available tankers came from either direct examination of the vehicle or from other sources—interviews, the incident reports, etc.

In 25 of the 33 instances, the tank was found to have been significantly damaged. The level of damage ranged from scratches, to dents, to cave-in of an entire side of a doubles train.

Twenty-three of the vehicles had suffered loss of product by means of the following failures:

13 cases - manhole cover dislodged or leaking

5 cases - split in tank weld seam

4 cases - puncture in tank wall

1 case - both split seam and puncture

Manhole Cover Failures

Manhole cover failures ranging from total dislodging of the cover to a sustained leakage after rollover have been observed under a variety of rollover impact conditions. Manhole cover failures were experienced with tanks which struck rigid pavement as well as snow banks. Shown in Figures 5.1 and 5.2, for example, are tanks having the distinctly flattened sidewalls which result from rollover onto a rigid pavement, the situation most likely to dislodge manhole covers.

Shown in Figure 5.3 is a photo taken at the accident scene of a burned tanker which has lost two of its manhole covers after rolling over on a Detroit expressway. One of the covers can be seen laying on the ground near the tank. A more "gently" deformed tank shell is shown in Figure 5.4. Manhole covers were still intact on this vehicle, but leaking, after the vehicle overturned onto a snow bank.

Although the anecdotal nature of the available information illustrates that a problem exists, a statistically-sound basis for inferring the role played by manhole-cover failure is not possible, since the reporting of specific types of manhole-cover failure was not done consistently. Nevertheless, the complete dislodging of manhole covers is looked upon as constituting the most hazardous common experience since the fluid load is released at such a high flow rate that a "river" of fuel is created. The "river" flows rapidly along the natural drainage profile of the roadway, posing a particular threat to other vehicles either involved in, or stalled by, the accident. If the fuel is ignited, of course, the rapid flow of the "river" implies a rapidly advancing flame front.



Figure 5.1. Doubles train showing flattened sidewalls resulting from rollover on rigid pavement

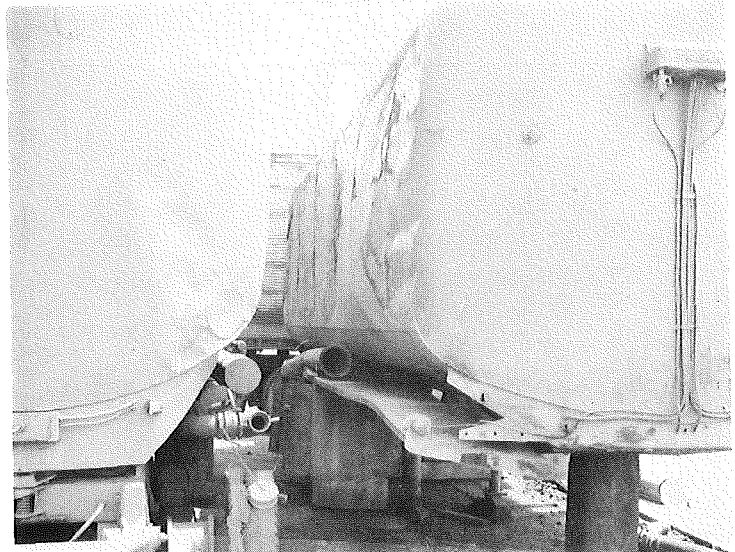

Figure 5.2. Single trailer with pavement-flattened sidewall.



Figure 5.3. Accident scene showing tanker that has suffered dislodgement of two manhole covers with ensuing fire.



Figure 5.4. "Gently" deformed tanker which rolled over onto a snow bank.

Weld Seam Failures

Of the five cases in which a split occurred along a weld seam, all such failures were confined to a few inches in length of split. One such vehicle, the aluminum-shell tanker shown repaired in Figure 5.5, rolled over onto its right side causing a split in the seam, "A," as well as internal tearing of all of the bulkheads separating the four tank compartments. Virtually the entire fluid load of 13,000 gallons was then spilled out through the split in the front head seam.

In most cases of weld seam failure, the split was seen to occur in the concave portion of a fold in the tank skin such as shown by the arrow in Figure 5.6. Although the flow rate through such openings may be only of the order of 5 to 10 gallons per minute, large fires were seen in two cases which caused fatalities. Shown in the foreground of Figure 5.7 is a leak from such a weld seam split produced during one of the tanker rollover tests to be discussed in the following section of the report.

Speaking generally, weld seam splits were found most commonly at the junction of the rear head to the sidewall as sketched in Figure 5.8. This failure appears to be especially likely on those tanks for which the rear head meets the sidewall with an oblique butt weld rather than by means of an overlapped head flange and sidewall plate, as shown in Figure 5.9. It is known that the more elliptic-section tankers are commonly designed with the overlapping head flange construction, although the achievement of this feature with the large-radius-sidewall tanks which are of interest in this study may be more difficult.

Tank Puncture

The mechanisms causing tank puncture were clearly identified in only two cases. In one case, the tank was pierced by the tractor frame rails and in the other case, the tank was penetrated by a pavement drop-off edge at a construction site. Other punctures entailed unidentified roadside appurtenances. In general, we notice that puncture of Michigan's typical steel tanks requires contact with a rather small, rigid object. Shown in Figure 5.10 is an example of a localized tank

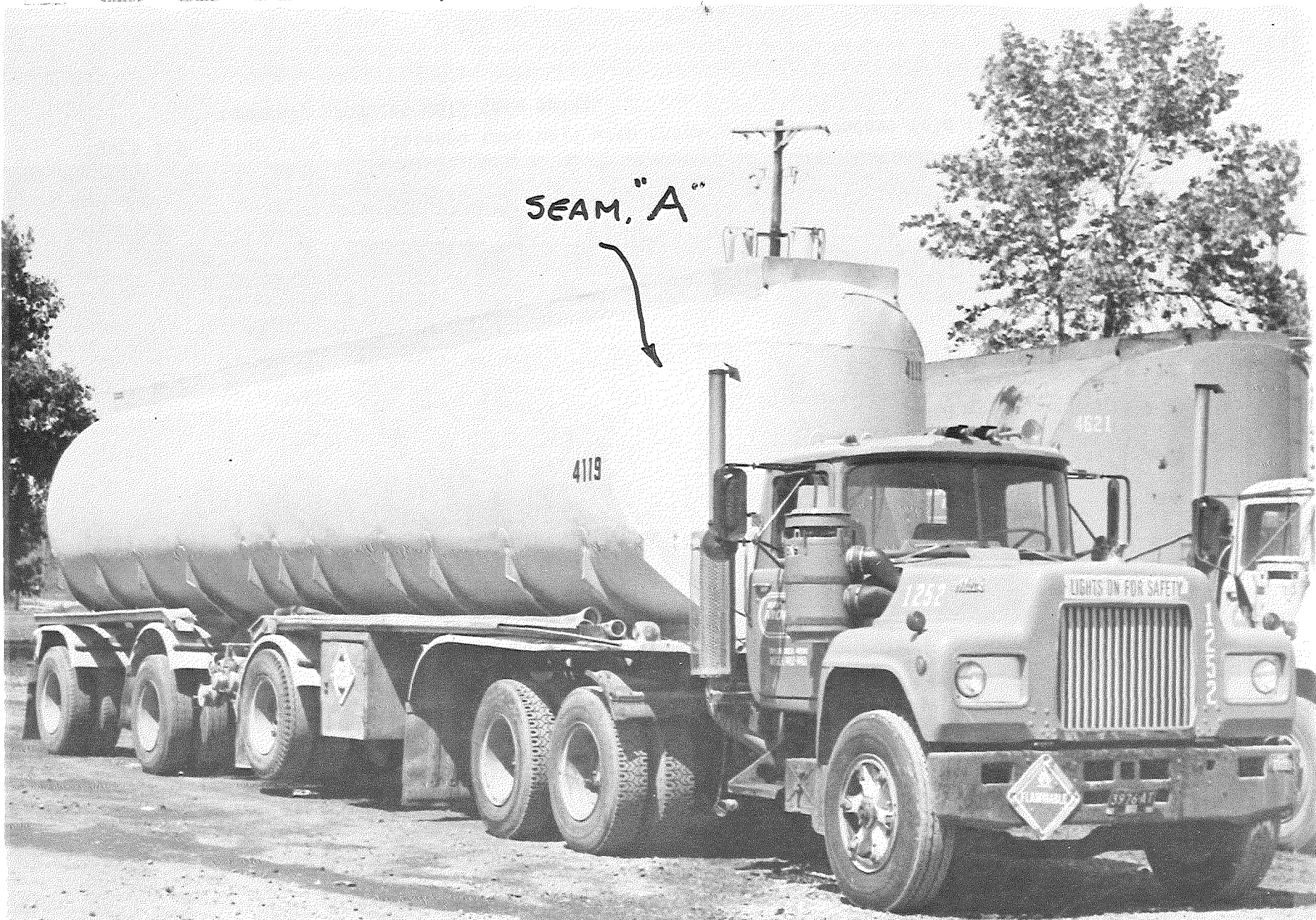

Figure 5.5. Aluminum-shell tanker shown repaired after a rollover which ruptured tank at weld seam "A".



Figure 5.6. Side view of flattened tank wall with characteristic concave fold (arrow) such as commonly produces weld seam split.



Figure 5.7. Weld seam split (arrow) observed following rollover experiment discussed in Section 5.2.

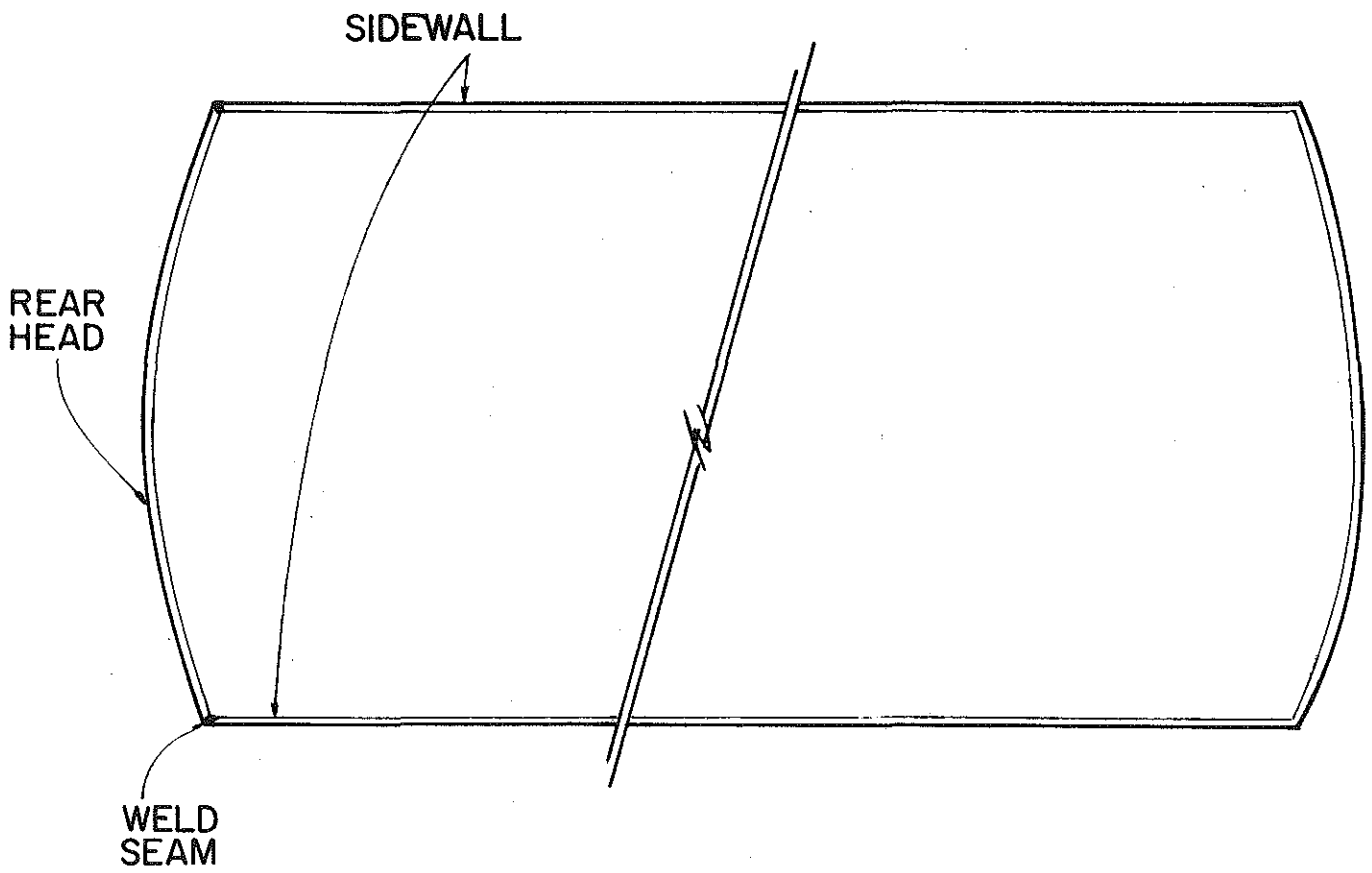

Figure 5.8. Butt-type weld seam.

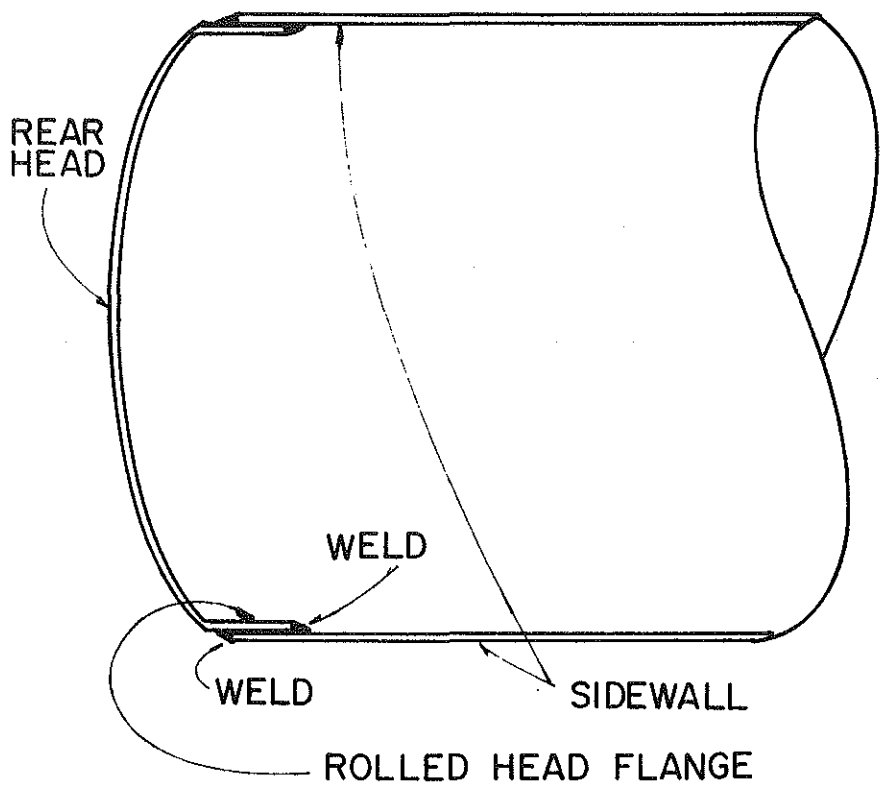

Figure 5.9. Double-weld seam which is possible with head section employing a rolled flange.

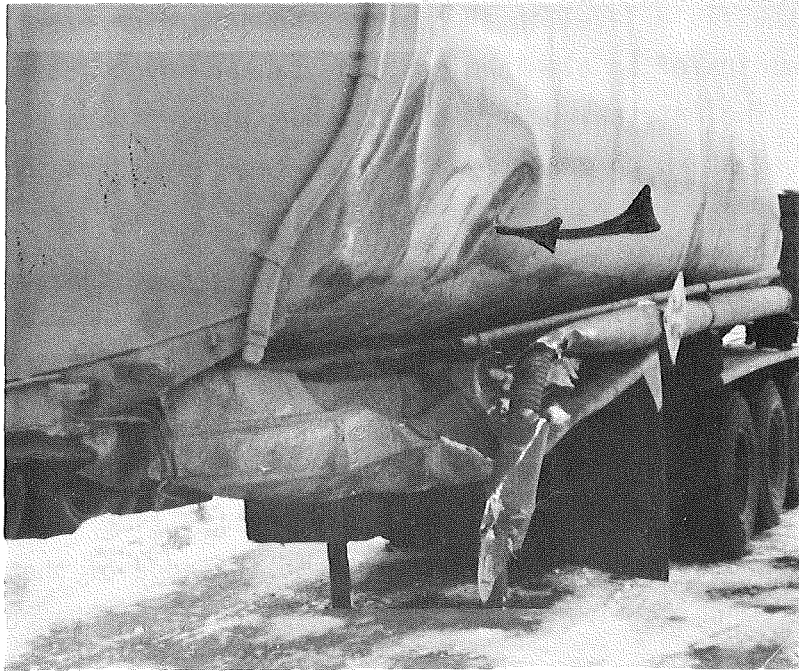

Figure 5.10. Tank puncture incident deriving from localized loading of the tank shell by an unknown object in a collision.

deformation in which a small puncture was created. By contrast, the large deformation which is evident in the leading corner of the second trailer in Figure 5.11 did not involve a sufficiently localized loading to cause puncture.

Tank Shell Integrity in a Fire

In the cases of aluminum tank trailers which did rollover, with an ensuing gasoline fire, the aluminum shell material melts wherever it extends above the fluid level in the tank. Shown in Figure 5.12 is a photo of the remains of an aluminum gasoline tanker involved in a rollover and fire. The internal baffle and bulkhead plates have been burned down to the level at which the remaining fuel reposed at the time the fire was extinguished.

Of course, a steel-shelled tanker will not melt at the temperatures attainable in a gasoline fire. By way of contrast to the aluminum tank shell shown above, the steel tank shell in Figure 5.13 is notable. The photo reveals the final level of fluid repose upon extinguishment of the fire by the line of discoloration evident on the rear head. Note that the vehicle was resting on its right side at the time of the fire, and that the apparent fluid level goes right to the edge of the manhole cover opening from which fluid spilled upon dislodging of the cover.

Moreover, the tank failure investigation served to provide actual examples of failure mechanisms, although little of statistical significance can be concluded. It was determined that manhole-cover failure constituted the primary means for spillage of fluid product, although the frequency with which total dislodgement occurs cannot be identified. Additionally, the weld seam failure occurring at the oblique butt-welded juncture of the head and sidewalls appears to be a common fault.

5.2 Integrity of Manhole Covers

Shown in Figure 5.14 is a typical manhole cover design such as has been popular in Michigan for gasoline and fuel oil transport. The manhole cover assembly is situated on top of the tank between the two protective rails. The device shown in the sketch typically contains any or all of the following items:



Figure 5.11. Double tanker showing deeply indented leading corner of second trailer's tank - no leakage occurred.



Figure 5.12. Remains of aluminum-shell gasoline tanker following rollover and fire (courtesy of S-K Services).

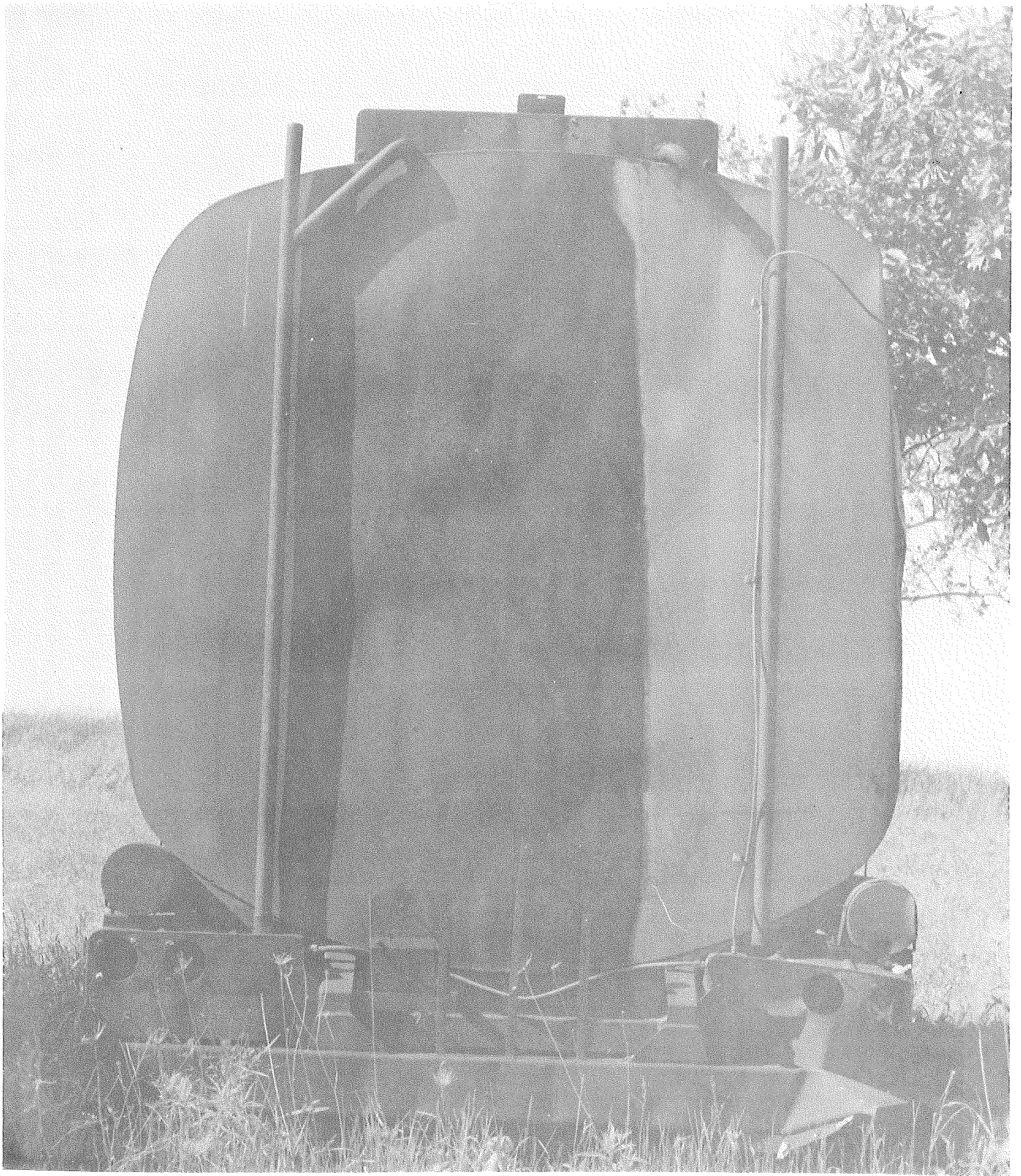

Figure 5.13. Rear view of steel-shell gasoline tanker involved in rollover and fire.

DOME COVER

FILLER COVER

BREATHER VENT

CLAMPING BAND

FUSIBLE PLUG

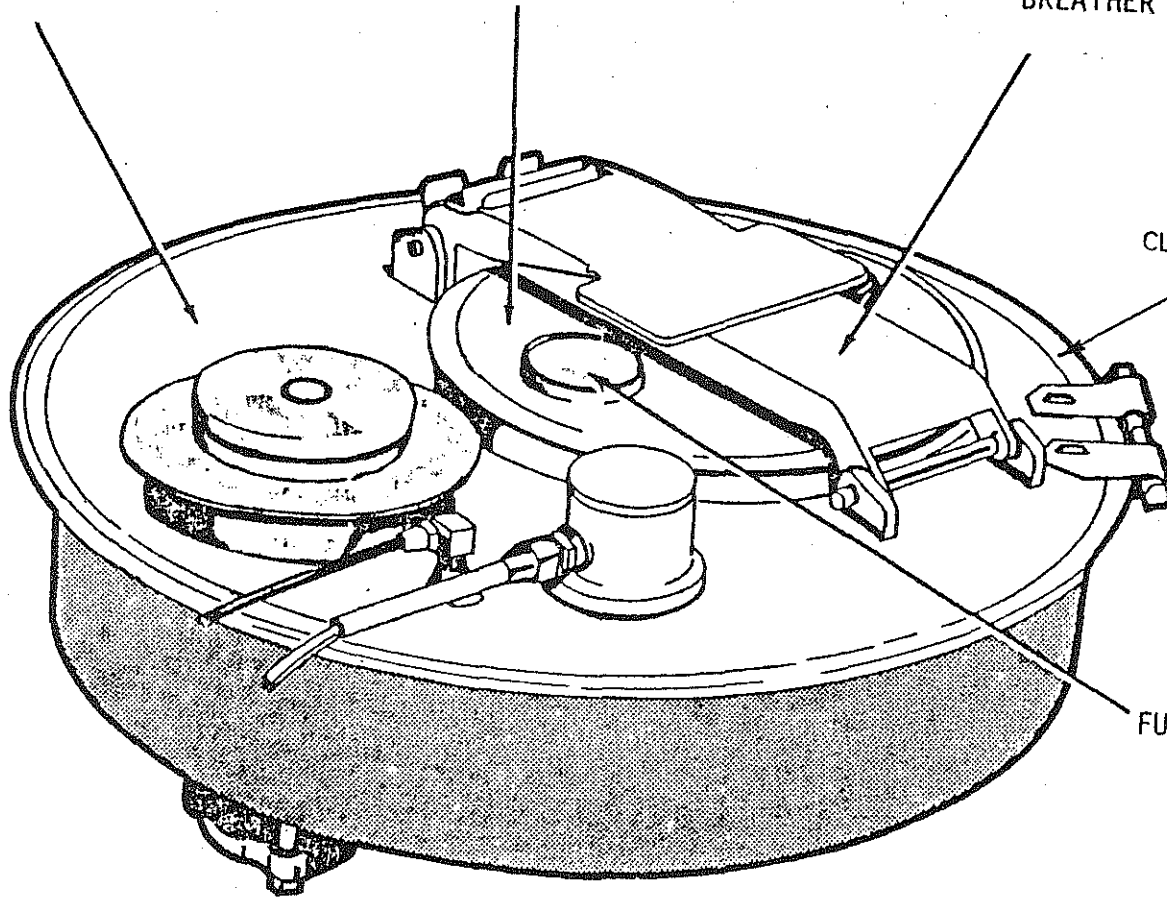

Figure 5.14. Typical manhole cover assembly employing clamping-band-type fastening.

- 1) Fill cover which is opened to permit loading product from the top of the tank.
- 2) High capacity vent by which the fill cover is spring loaded to open with 3 psi internal pressure.
- 3) Low capacity pressure and vacuum vent.
- 4) Vapor recovery shroud and remotely operated valve for discharge of vapors into a separate "recovery" piping arrangement during bottom loading of the tank.
- 5) Fusible vents which open when immediate fire temperatures melt a solder-like fuse cap.
- 6) Liquid level sensor intended for use in shutting off inlet flow when compartment has been filled by means of bottom loading.

Although certain of these features are present pictorially in Figure 5.14, the key design feature which has led to special concerns regarding manhole cover integrity is the indicated clamping band. By means of tightening this band, the entire manhole-cover assembly is fastened to the flanged hoop (or so-called "weld ring") which forms the manhole opening in the tank itself. The integrity of such manhole-cover assemblies and their attachment hardware is currently addressed by the Code of Federal Regulations #CF49-178.341-3 which states:

(a) Each compartment in excess of 2,500 gallons capacity shall be accessible through a manhole of at least 11 x 15 inches. Manhole and/or fill opening covers shall be designed to provide secure closure of the openings. They shall have structural capability of withstanding internal fluid pressures of 9 p.s.i.g. without permanent deformation. Safety devices to prevent the manhole and/or fill cover from opening fully when internal pressure is present shall be provided.

The accident experience cited in the preceding section led to the hypothesis that the 9 psi internal pressure requirement of the regulation was inadequate for assuring that manhole covers would not become dislodged in rollover impacts.

Experimental Program of Rollover Impact

In order to test the stated hypothesis, a set of experiments was planned to determine the maximum level of internal fluid pressure which is likely to occur in a gasoline tanker which suffers a rollover impact against a flat paved surface. A set of four individual experiments was conducted using full-size gasoline tank trailers.

Experiment #1 - The first test was conceived as representing a severe rollover event such as would derive if a rapid steering maneuver was attempted such that the tank trailer could gain a large level of roll velocity before its tires came off of the ground. Computerized simulation was employed to predict the roll and elevation trajectory shown in Figure 5.15. We see that a very severe rollover event of this type places the tank at a rather steep roll attitude by the time ground contact is made. The impact condition further entails a final angular velocity of 2.6 rad/sec and a vertical velocity at the mass center of 16.2 ft/sec.

A full-scale kinematic equivalent of this impact condition was achieved through use of the test rig shown in Figures 5.16, 5.17, and 5.18. By this arrangement, the vehicle was set up to achieve a free roll motion about a selected longitudinal axis which was near the center of the tanker's axles. Figure 5.16 shows certain auxiliary vehicles which were used to hold down or rigidly locate elements of the pivot mechanism. Figure 5.17 shows a pipe element which constitutes a pivot pin about which the vehicle rotates, a truss structure which locates the pivot fulcrum, and one of the upright supports which becomes released to initiate the drop. Shown in Figure 5.18, the vehicle is perched upon two upright poles which support the tank by means of rollers set into box-like fittings of each end of the tank. The roller, which is fastened to the pole, bears against an inclined plate such that the vertical load of the tanker tends to push the pole away from the tank. Upon suddenly releasing tension on the overhead cable, the poles are both pushed out and the tanker falls in a free rotation about the pivot. Since the tank strikes the ground with a contact force which passes very nearly through

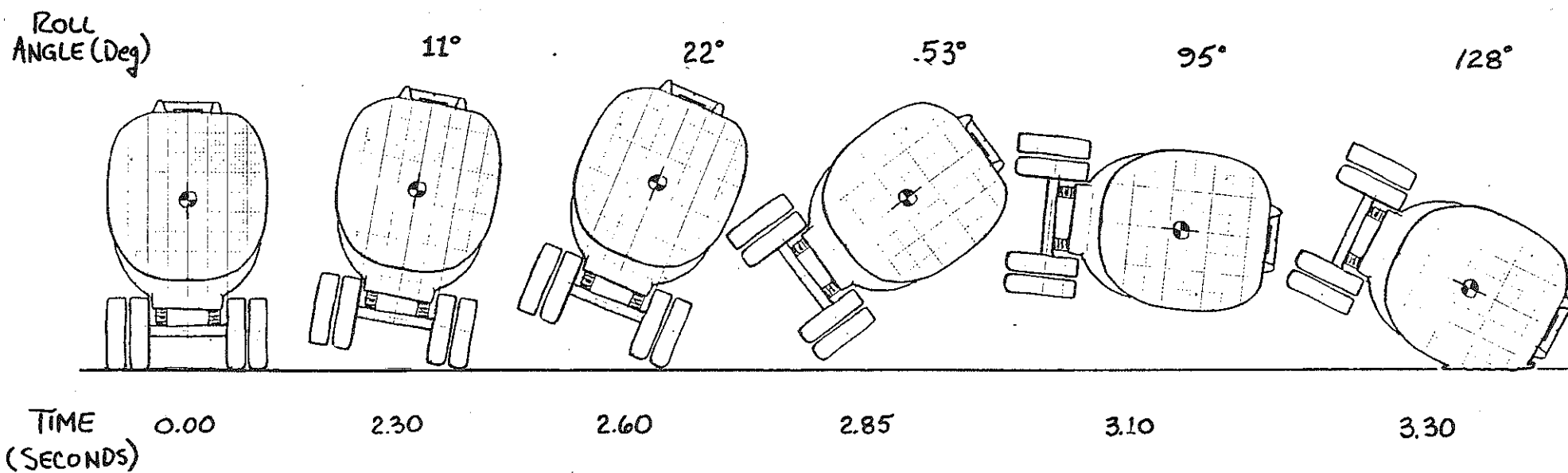

Figure 5.15. Time sequence of roll attitude and c.g. elevation representing a reference case for a severe rollover.

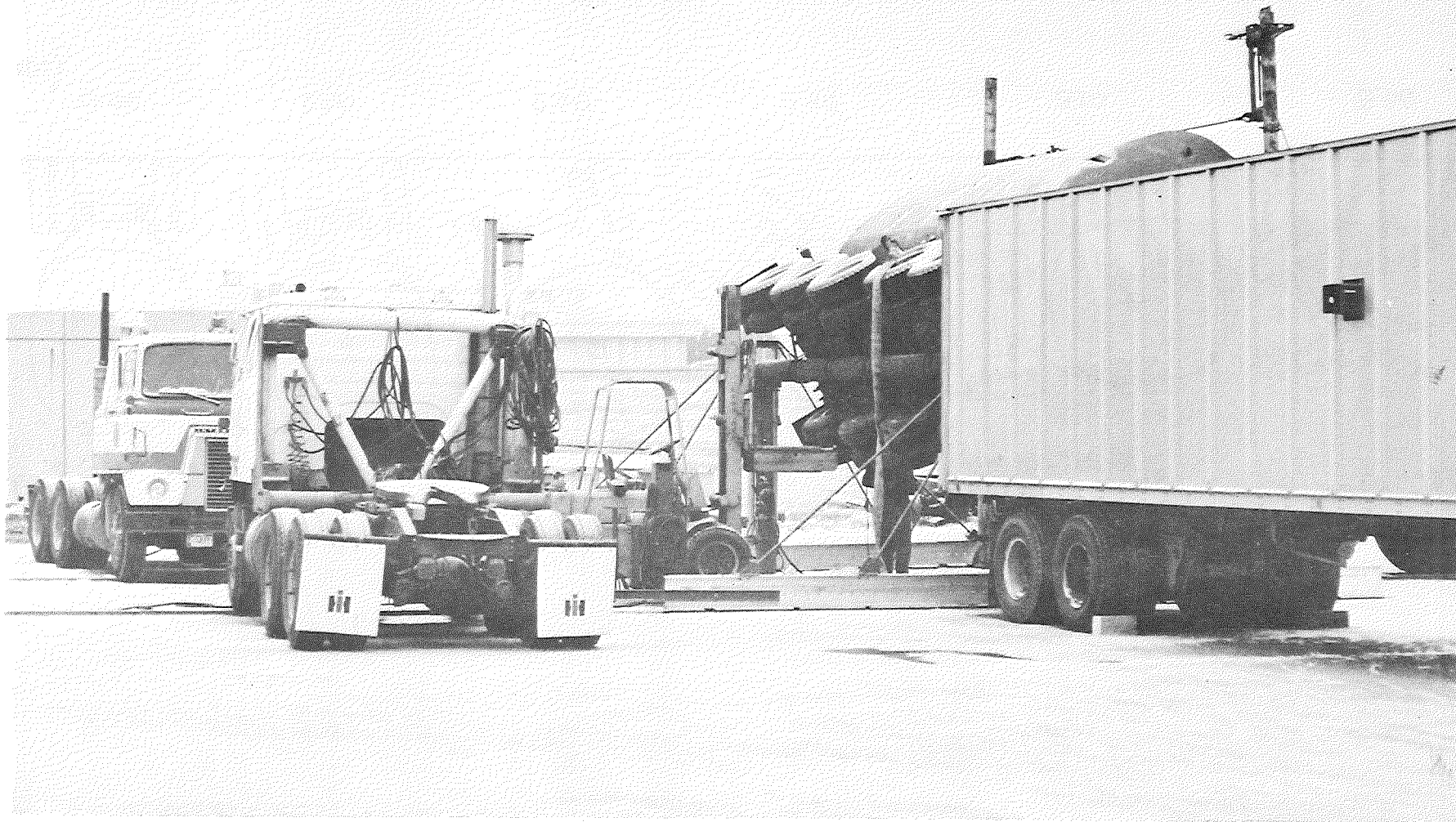

Figure 5.16. Miscellaneous support vehicles used to locate the pivot apparatus in severe rollover experiment.

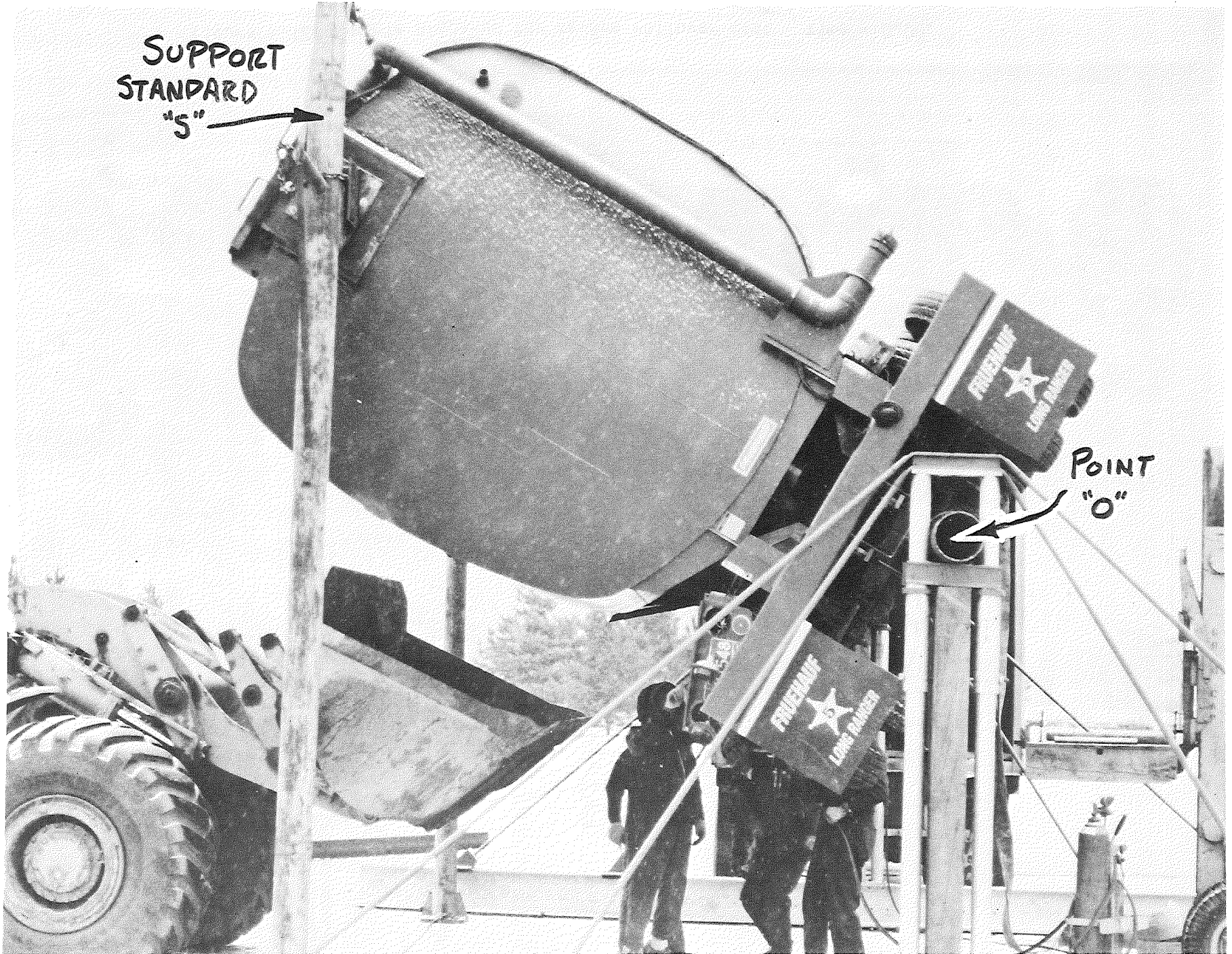

Figure 5.17. Tanker located by a pivot. Tanker configured to rotate about point "O" upon release of the support standard, "S".

126

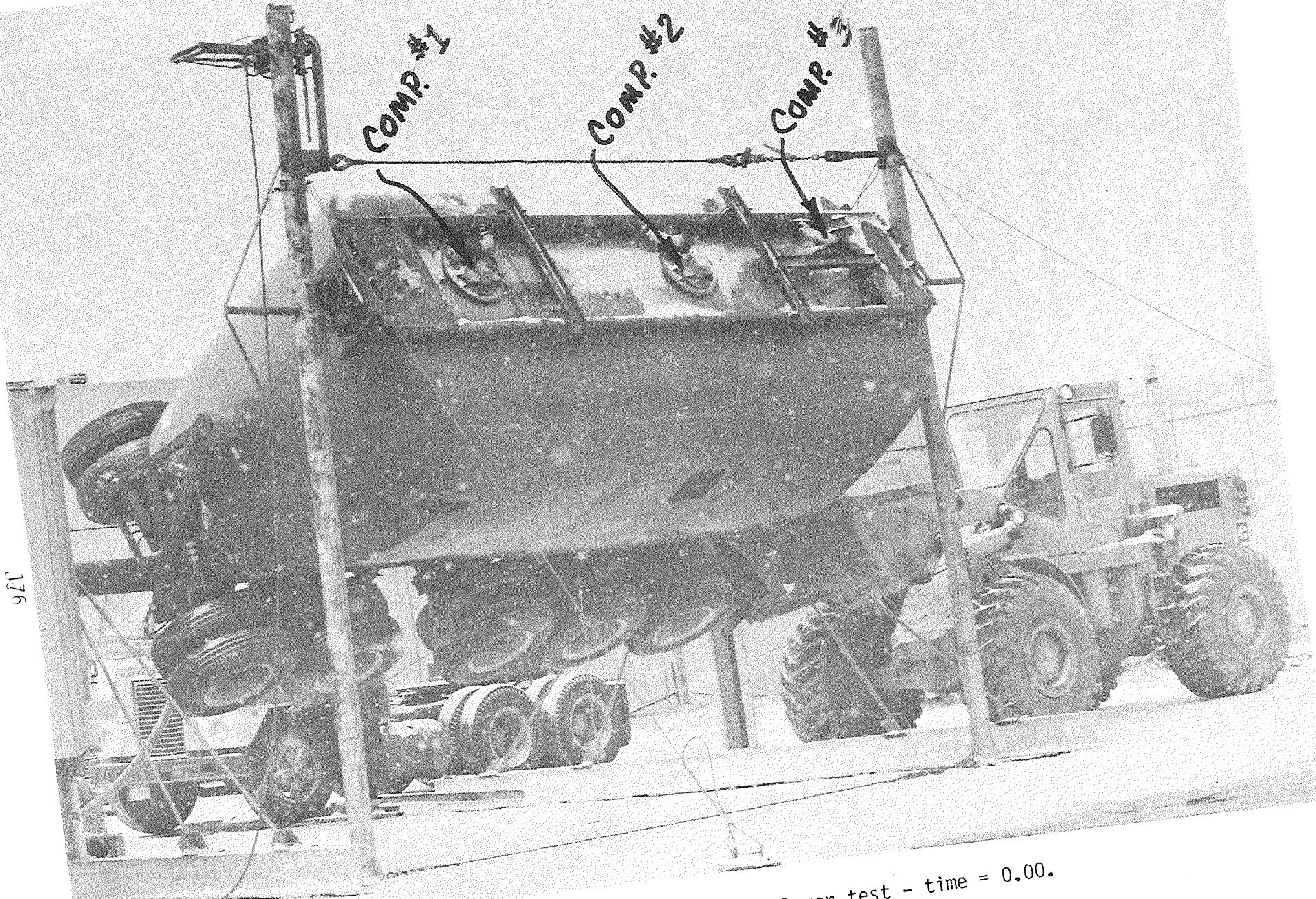

Figure 5.18. Vehicle prepared for severe rollover test - time = 0.00.

the center of percussion of the tanker, residual motions following impact are insignificant.

The test vehicle itself is a 7,700-gallon, 10-ga steel-shell tanker comprising the full trailer of a typical Michigan double. The tank has three compartments, of capacities 3,550 gallons, 1,450 gallons, and 2,700 gallons, respectively from front to rear. For the first experiment, the front and rear compartments were nominally filled with water, leaving a three-percent outage volume, or free space, in both loaded compartments. This loading condition was chosen since it yielded the design gross load of the vehicle, 65,000 lbs. The manhole covers were all of the clamping-band type discussed earlier. The manhole cover in the filled #1 compartment was left in its as-designed state while the #3 cover was mechanically blocked to prevent its dislodging. Transducers were installed to record two fluid pressures adjacent to the manhole in both the first and third compartments, two acceleration signals normal to the impact point, and the instantaneous angular position of the vehicle during its fall. Data were recorded on an FM tape recorder, as well as on oscillographic pen-chart recorders.

Shown in Figure 5.19 and 5.20 are photos of the tanker in motion and, then, impacted with its #1 manhole cover dislodged. In Figure 5.21 we see the "river" that was created within two or three minutes following the dislodging of the #1 manhole cover. Subsequent inspection showed that the bulkhead between compartments #2 and #3 had failed in the vicinity of the impact deformation. Further, following completion of the second impact experiment using the same test vehicle, it was discovered that an artificial cushioning of the internal fluid pressures had taken place due to partial collapse of air tanks which existed inside each of the three compartments. The air tanks had been installed inside the compartments during a previous research study [2] for purposes of displacing fluid so that a water load would yield the same inertial parameters as a reference loading of gasoline. Thus, neither the first nor second experiment can be looked upon as providing a valid estimate of the maximum levels of internal pressure which may be exerted against a manhole cover in a rollover. Nevertheless, the

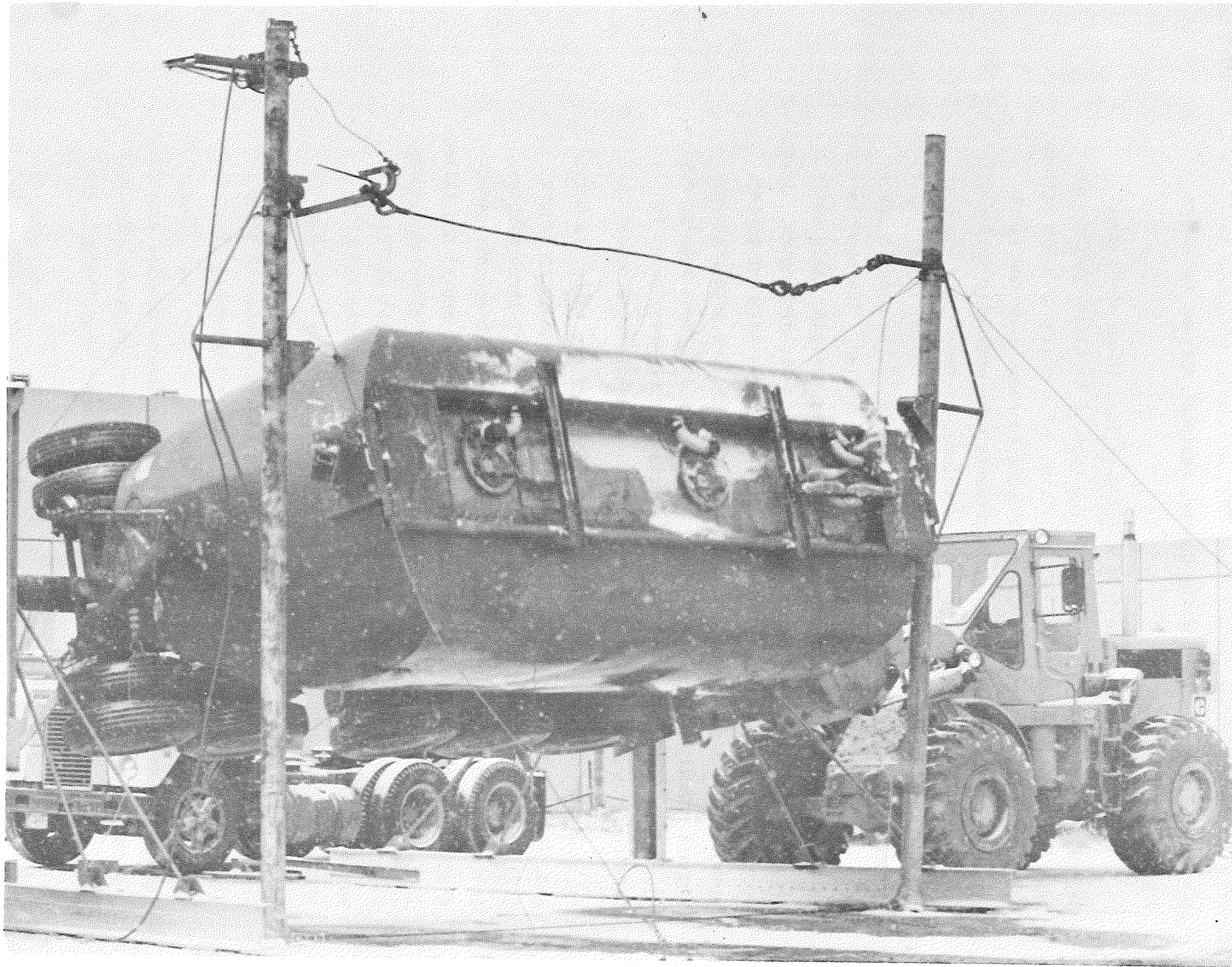

Figure 5.19. Severe rollover test, time = 0.30 sec.



Figure 5.20. Severe rollover test, time = impact + 1 sec.

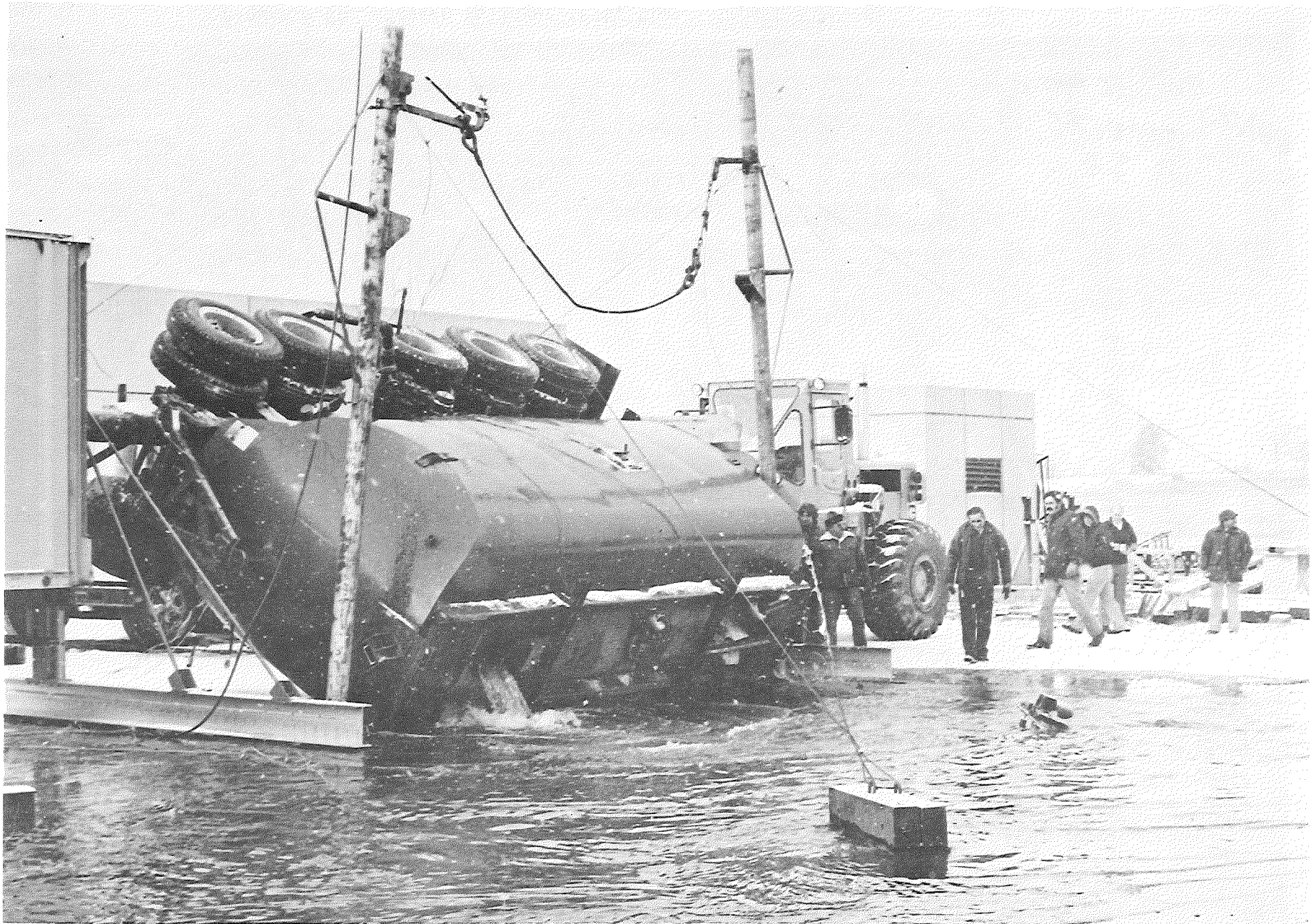

Figure 5.21. Scene showing the "river" of fluid released due to dislodgement of manhole cover.

results of these experiments do aid in obtaining an understanding of the mechanisms contributing to internal pressure.

Shown in Figure 5.22 are the recorded time histories from pressure transducers and accelerometers installed on the vessel. From the top, we see the two pressure signals from compartment #1, next the two pressure signals from compartment #3 and finally the two acceleration signals (which show signal, A_1 , limiting at 20 g's while the broader range accelerometer, signal A_2 , continues to yield a measurement). The pressures in compartment #3 pertain to a condition in which the manhole cover is blocked to prevent dislodgement. The pressures in compartment #1, on the other hand, provide a measure of the pressure causing one specific manhole cover to dislodge. Although we see variations in the noise content of the four pressure signals, the nominal response entails a low frequency peak in the range of 20 to 25 psi and high frequency spikes from 30 to 50 psi. Interestingly, the signals obtained in the "blocked" compartment are virtually the same as those obtained in the compartment in which the 20-inch diameter orifice was opened, upon having dislodged the manhole cover. This result was initially surprising since it had been expected that failure of a manhole cover would act to relieve the pressures experienced in the involved compartment. The observation can be explained, however, on the basis of the very limited time period over which peak pressures are sustained, as contrasted with the time needed to accelerate a sufficient quantity of fluid out of the manhole opening to provide a pressure-relieving effect.

The accelerometer signal, A_2 , provides a continuous recording of accelerations normal to the ground plane, showing a noisy, and relatively low-level, response for the first 30 milliseconds, followed by a rather sustained pulse of approximately 25 g's amplitude. Double integration of the A_2 signal, by graphical means, yields a net deflection of the tank wall which agrees well with the nominal 8-inch maximum deformation measured on the vessel.

In Figure 5.23 is shown the failed manhole cover, characterized by a stretched clamping band and, as shown by another view in Figure 5.24, also incorporating a marked bow in the cover itself as a result of the high internal pressure.

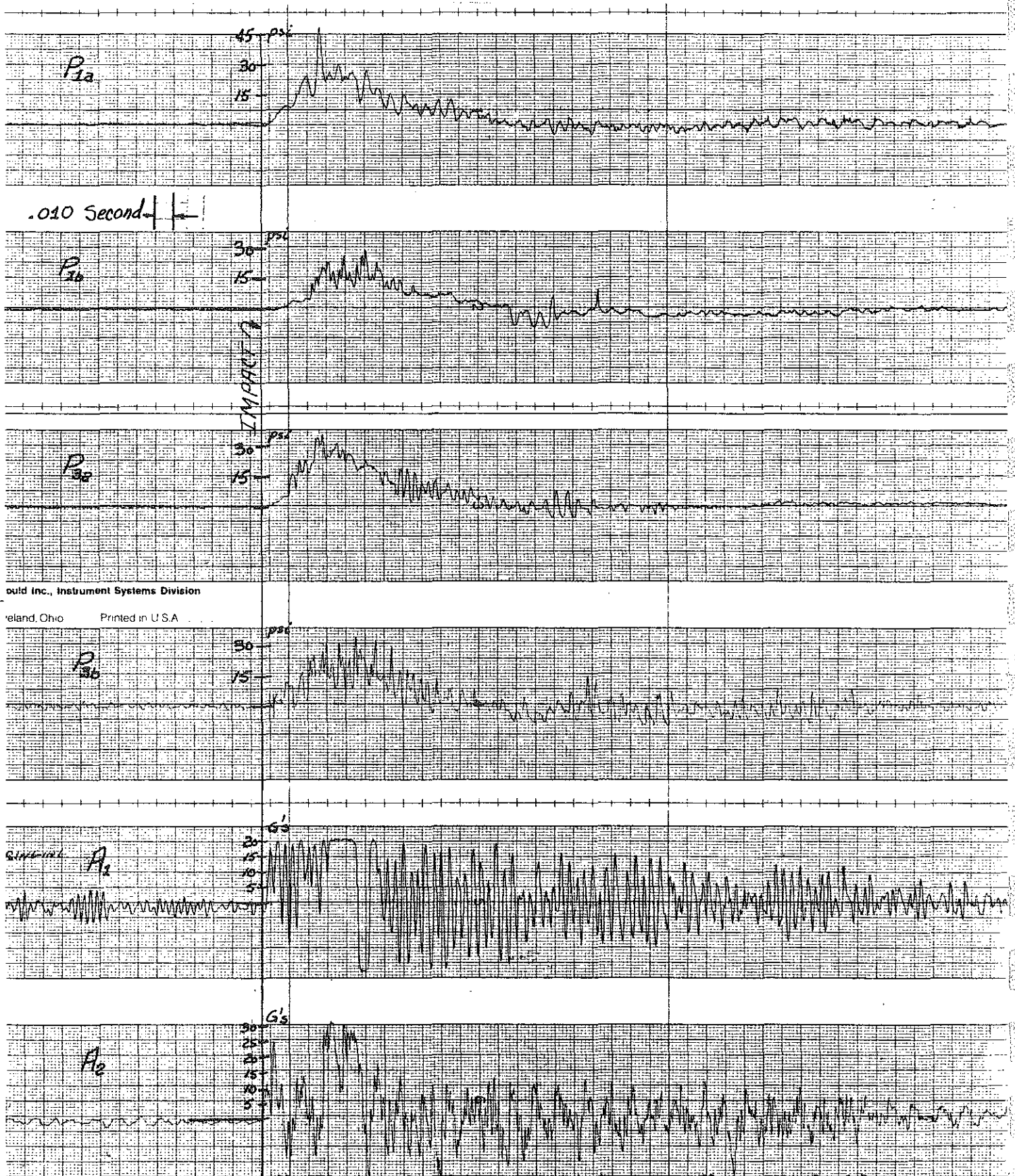

Figure 5.22. Time histories of data gathered during severe rollover test.
 P_{1a} & P_{1b} - compartment #1, P_{3a} & P_{3b} - compartment #3

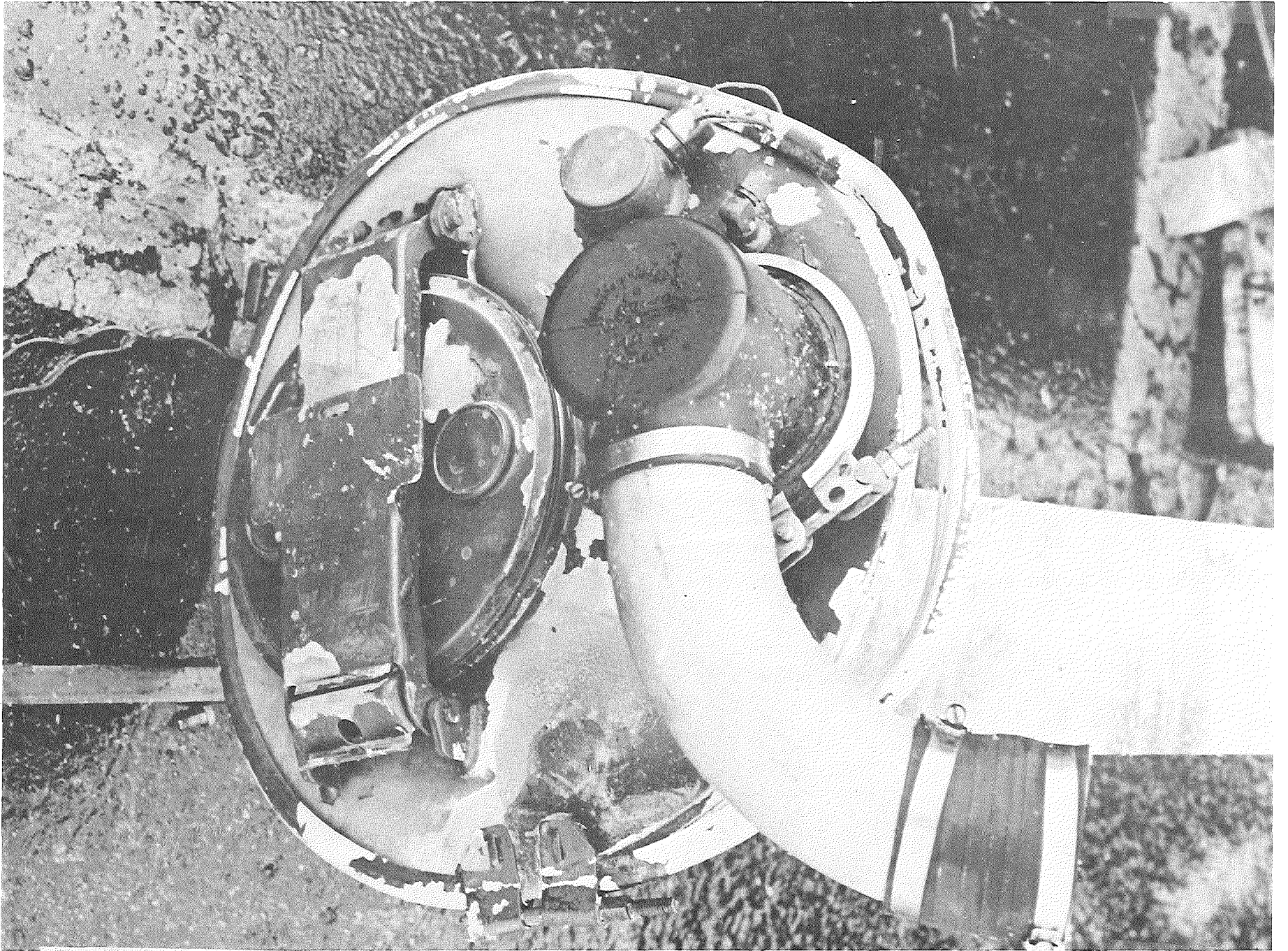

Figure 5.23. Failed manhole cover showing stretched clamping band.



Figure 5.24. Failed manhole cover showing bowed profile.

Experiment #2 - The second rollover impact test was of the simple "tip-over" variety, by which the tanker was brought just beyond its point of unstable equilibrium, with zero initial roll rate. The vehicle then rotated about its tires until the tank shell impacted against the ground at a roll attitude of approximately 95 degrees from the vertical. Shown in Figures 5.25 and 5.26 are views of the set-up for the second experiment. The vehicle was initially supported at a roll attitude of approximately 15 degrees so as to minimize the level of force needed on the cable with which the tanker was towed to the point of roll instability. The tank's three compartments were all filled with water, leaving only a three-percent outage, or vacant volume, within each compartment. A clamp-ring type manhole cover was again installed on compartment #1, while blocked covers were placed over the other two compartments. The tank was instrumented as before with two pressure transducers in each of compartments #1 and #3 and with one narrow- and one wide-range accelerometer fastened to the tank opposite the impact point.

Shown in Figures 5.27 and 5.28 are scenes at the moment of impact and a few seconds following the experiment. Again we see that the conventional manhole cover has been dislodged and that a large plume of water spray is produced at the moment of impact. Note that a substantial flow of liquid is sprayed out through the 3 psi vent of the blocked conventional manhole cover on the left in Figure 5.27. The center compartment, which was not instrumented, has been covered for this experiment with a blank plate having simply a two-inch open standpipe to represent vent flow.

Shown in Figure 5.29 are time histories of pressure and acceleration signals recorded in the second experiment. Arranged from top to bottom we see, as before, two pressure signals from compartment #1, in which the conventional manhole cover failed, followed by the two pressure signals from the top of the blocked #3 compartment, followed by two accelerometer signals. Again, the accelerometers are both oriented to record accelerations normal to the ground. Note that the signal, A_1 , is limited at 20 g and thus is not useful in determining peak accelerations.



Figure 5.25. Tanker inclined to an initial roll angle of 15 degrees for "tipover" experiment.



Figure 5.26. Tanker with tow cable used to initiate tipover.

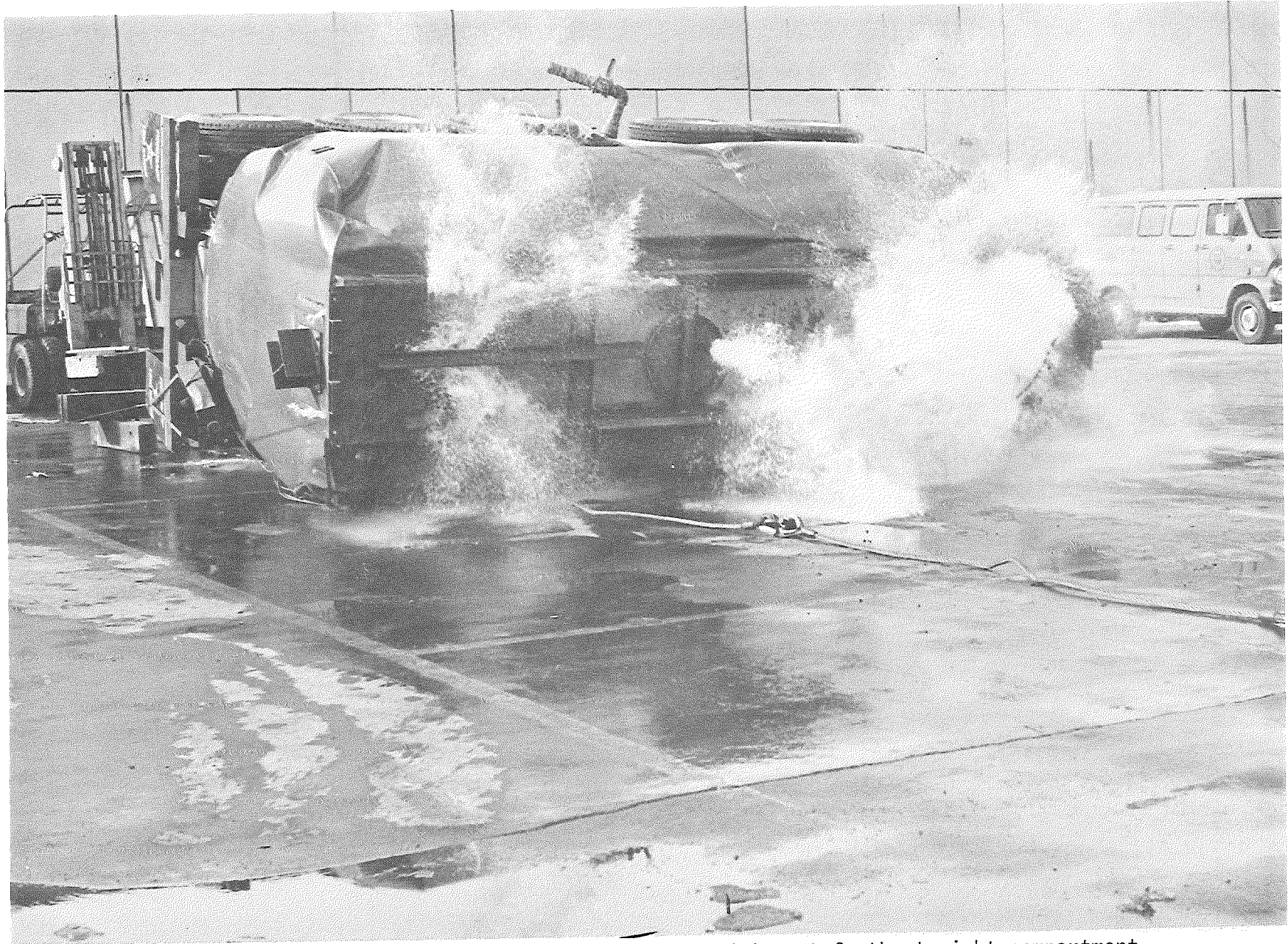

Figure 5.27. Tipover impact with manhole cover dislodging at farthest right compartment.

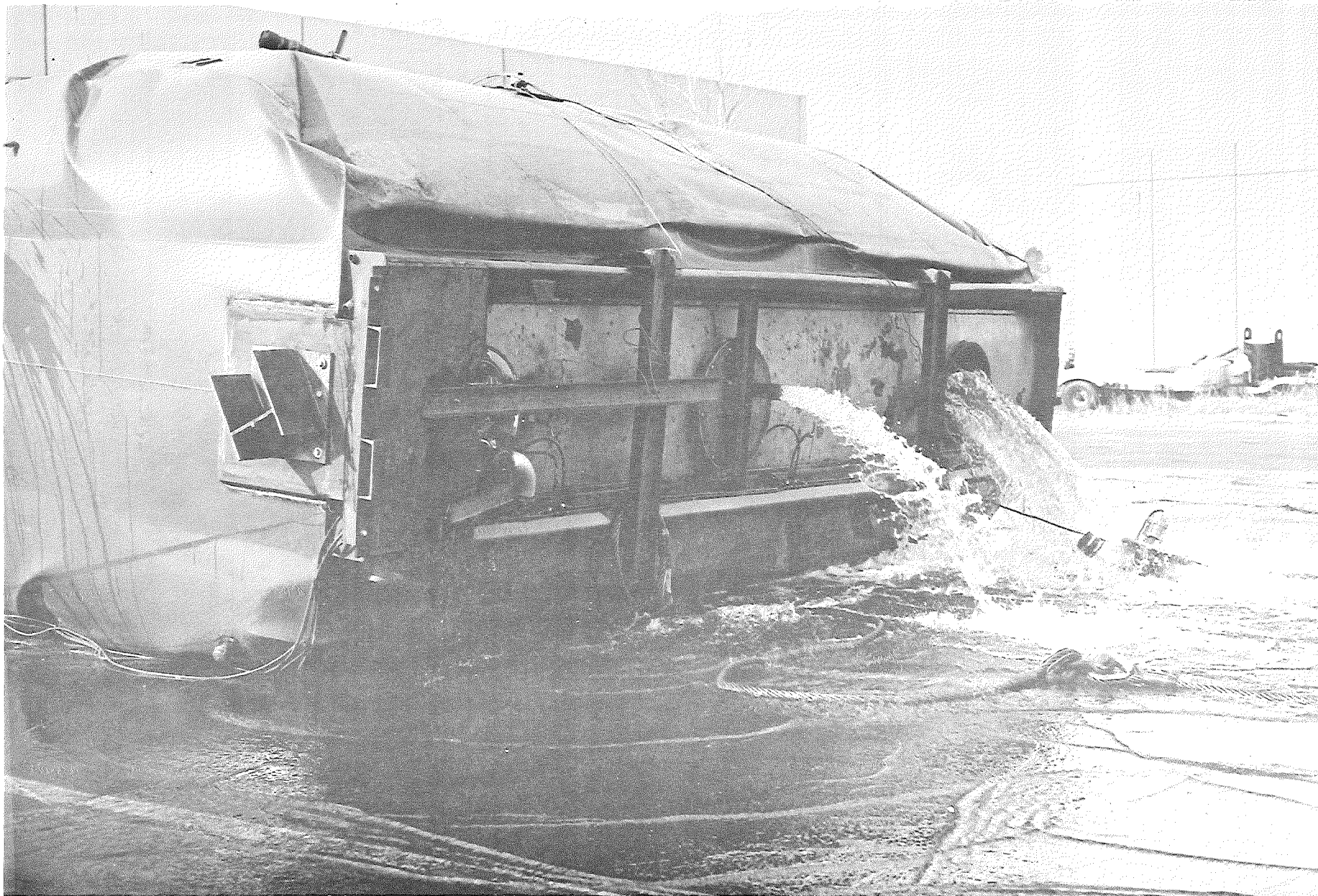

Figure 5.28. Scene following tipover test.

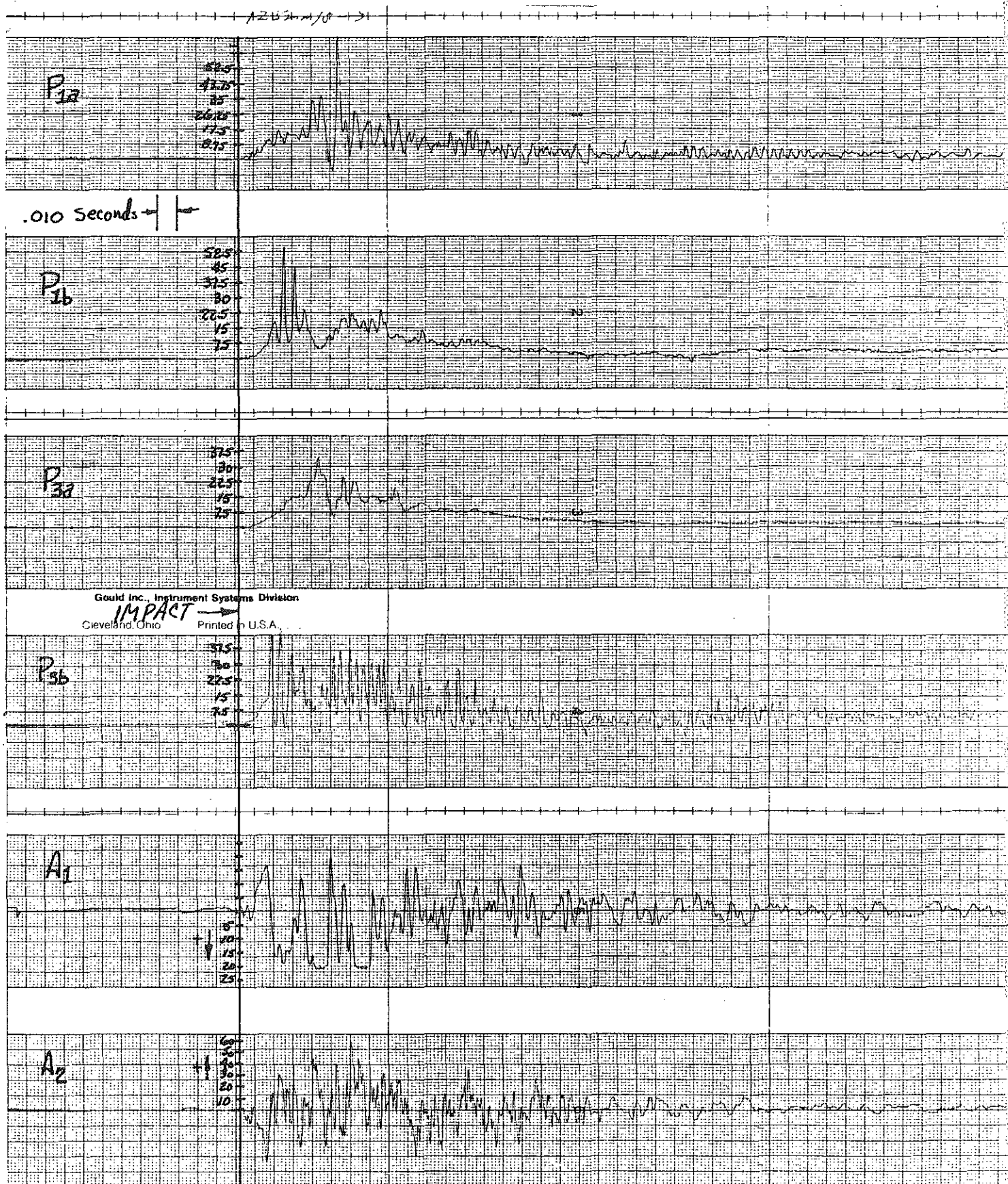

Figure 5.29. Time histories of data gathered during "tipover" test.

In general, the pressure data show a low frequency pulse which peaks in the vicinity of 20 psi, as well as a considerable number of high-frequency pressure spikes in the range of 30 to 65 psi. The acceleration signal, A_2 , shows a very noisy response with a considerable amount of higher level acceleration spikes, above 20 to 30 g's. It was also established that the nominal deformation of the tank shell entailed a maximum deflection of 6-1/2 inches.

As was stated earlier, experiments #1 and #2 suffered from an anomalous cushioning mechanism due to the partial collapse of air tank elements which remained in each compartment from a previous test activity. Although it had been previously thought that these tanks would appear rigid to the brief pressure pulses encountered here, partial collapsing was observed after careful inspection of the inside of the vessel following the second experiment. As a result, two additional tipover-type tests were conducted to obtain specific examples of the internal pressure levels which manhole covers must be made to withstand.

Experiment #3 - Shown in Figure 5.30 is a 9,300-gallon tanker set up for a tipover test. The tanker is, again, of 10 ga steel shell construction and incorporates three compartments sized, from front to back, 4,200, 1,400, and 3,700 gallons.

The tanker has four manhole cover positions, of which two were kept blocked in this experiment (namely, those covering compartments #1 and #2). The two manholes accessing compartment #3 were fitted with one conventional clamp-ring-type cover and one of cast aluminum construction whose design is diagrammed in Figure 5.31. The latter cover fastens by means of tension bolts and lugs which attach under the so-called "weld ring" which forms the manhole opening in the tank. The cast aluminum cover was employed in the experiment because of a desire to demonstrate the presumably good pressure resistance capability of a solid cover device employing reach-through, rather than clamp-ring-type fastening. Also, it was known that the cast aluminum device is currently being used on a substantial number of fuel tankers in the western U.S.

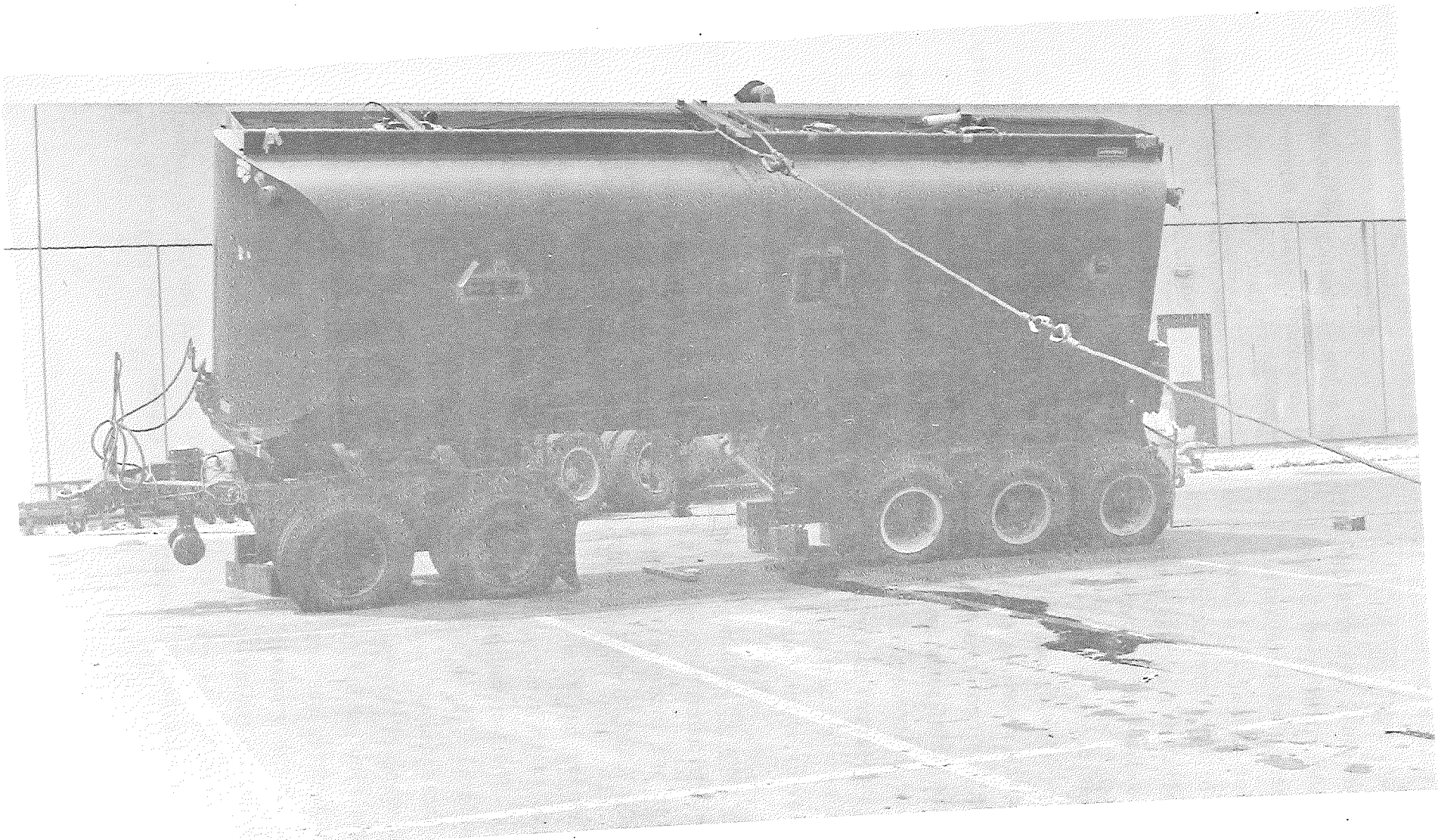

Figure 5.30. 9,300-gallon tanker used in experiments No. 3 and 4.

SYM.	PARTS.	QTY.	DESCRIPTION
1	1002	1	WELDING RING
2	7466	1	DOME BASE RING
3	1017	1	GASKET
4	7467	1	DOME CAP
5	7438	1	DOME LOCKING BAR
6	7469	2	SHAFT ASSEMBLY
7	7460	2	EXCESS PRESS SPRING
8	7461	2	BLEEVE
9	7468	2	LOCKING BAR CATCH
10	7465	4	DOME STUD
11	7464	4	DOME CLAMP LUG
12	7465	1	LOCK HANDLE
13	7466	1	RETAINING BOLT
14	7467	2	HINGE BOLT
15	7465	1	SAFETY LATCH BOLT/SPRING
16	7469	1	SAFETY LATCH
17	7470	1	DOME CAP GASKET
18	7471	1	VACUUM VALVE DISC
19	7472	2	VACUUM VALVE STUD/SPRING
20	7473	2	VACUUM VALVE SPRING
21	7474	1	PRESSURE VALVE DISC
22	7475	1	PRESSURE VALVE BALL
23	7476	1	PRESSURE VALVE BALL RET.
24	7477	2	PRESSURE VALVE BOLT ASBY
25	7478	2	PRESSURE VALVE SPRING
26	204	2	O-RING
27	206	4	O-RING
28	7481	4	DOME CLAMP ASSEMBLY
29	7482	4	DOME CLAMP LUG

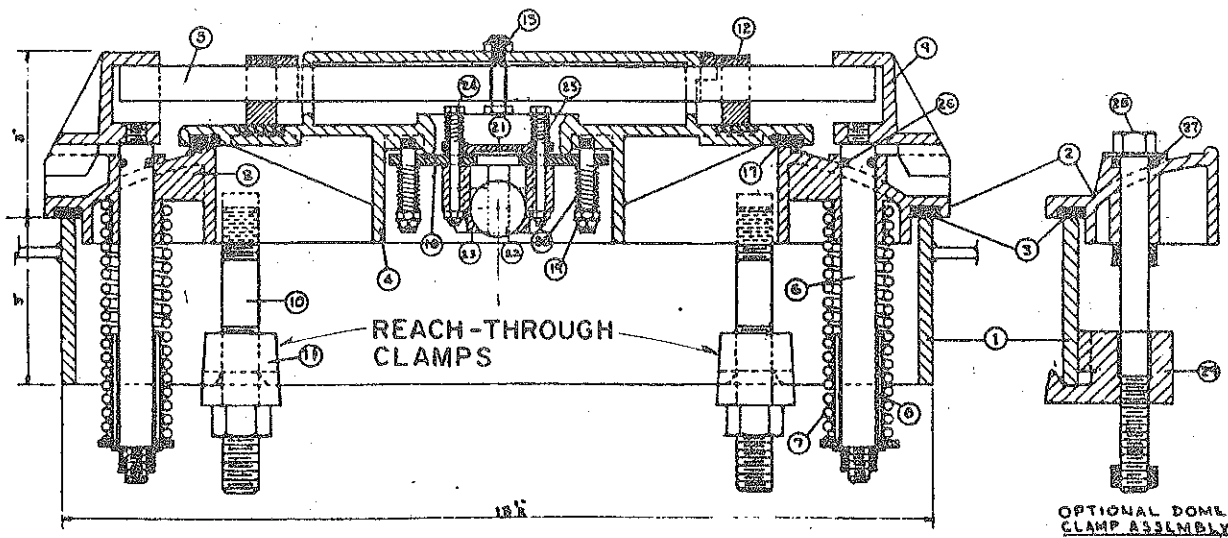
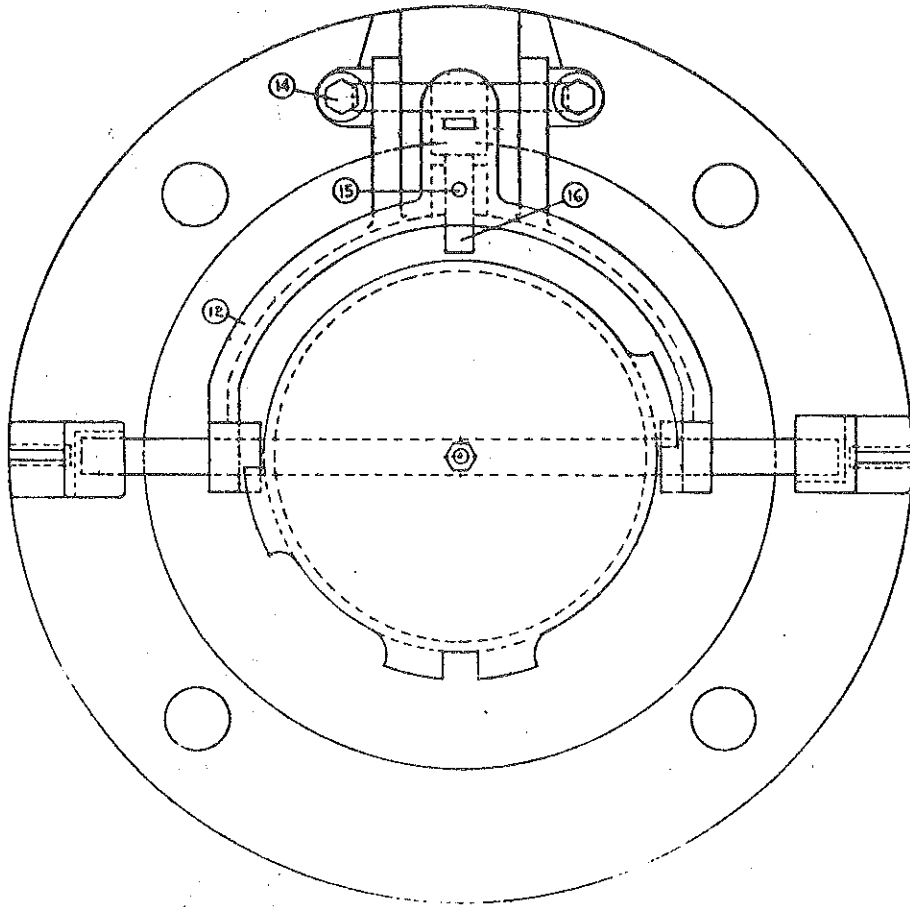

Figure 5.31. Manhole cover of cast aluminum construction employing "reach-through" type fastening to the tank.

All three compartments of the test tank were filled with water up to the 10-percent outage point. A higher fraction of the tank volume was left unfilled in this experiment because it had become apparent in the previous two tests that the volume of the tank which was displaced as a result of impact deformation was nearly equal to the 3-percent initial outage volumes which had been employed. Thus it was apparent that the simple compression of the air (or vapor) in the outage space would account for a large portion of the pressure surge experienced in the rollover of a nominally full tanker. This (later) experiment was thus designed to employ 10-percent outage to determine the advantages in impact pressure reduction which might be gained from such a filling practice.

Pressure transducers were employed in each of five locations, namely:

- P₁) adjacent to the (blocked) manhole cover on compartment #1
- P₂) adjacent to the (blocked) manhole cover on compartment #2
- P_{3a}) adjacent to the (cast aluminum) manhole cover on compartment #3
- P_{3b}) adjacent to the (conventional clamp-ring) manhole cover on compartment #3
- P_{3c}) at the height of the center of compartment #3, in line with the conventional clamp-ring manhole cover.

In addition to the pressure transducers, a single accelerometer was employed to measure the tank acceleration normal to the ground, at impact.

As shown in Figure 5.32, the tipover impact of this test vehicle produced dislodgement of the clamp-ring-type manhole cover, as before. The cast aluminum manhole cover remained intact following the rollover, although the spring-loaded fill cover became stuck in a partially opened position due to a malfunction in the spring retainer assembly. A minor design alteration was needed to correct the malfunction.

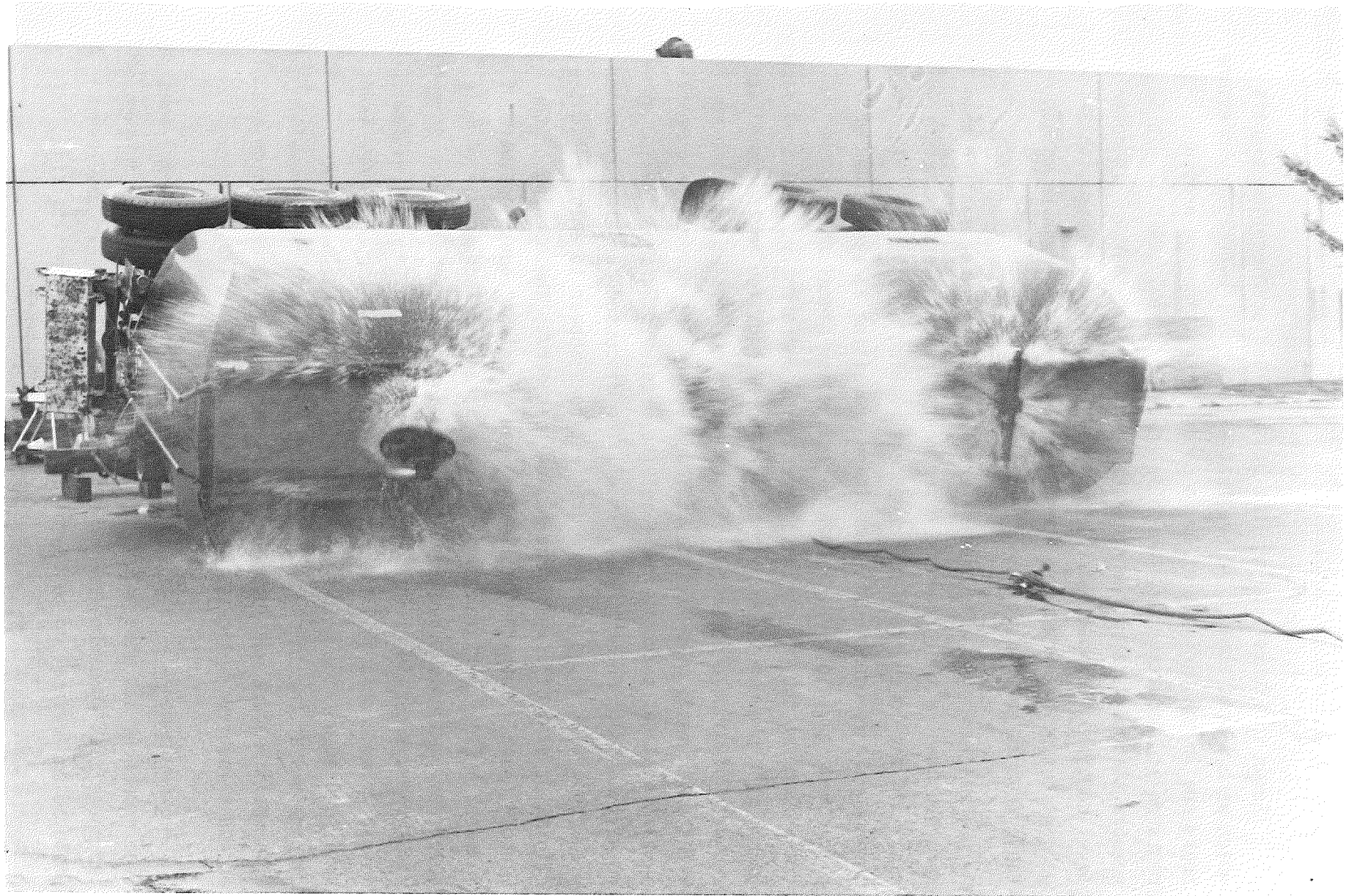

Figure 5.32. Moment of impact in the third experiment. Note clamping-band-type manhole cover dislodging at left.

Shown in Figure 5.33 are the pressure and acceleration signals which were listed above. We see that all of the low-frequency pressure peaks are in the vicinity of 16 to 20 psi except for the pressure measured at compartment #1, which is at approximately 24 psi. It is notable that certain of the pressure signals are rather low in noise level compared to those measured in the earlier experiments with 3-percent outage in each compartment. Peak levels of pressure spikes range from 20 to 55 psi.

Peak levels of acceleration are likewise somewhat smaller than were measured in the preceding experiments, reaching approximately 44 g's, with the lower frequency component peaking near 15 g's. The pressure signal representing the condition prevailing at the center of compartment #3 (signal P_{3c}) shows a less noisy signal than do the transducers at the top of that compartment. Apparently, localized flow or acoustic phenomena dominate the pressure condition in the immediate vicinity of manhole covers. As suggested in connection with the previous experiment, however, the dislodgement of the cover from compartment #3 does not serve to "relieve" the pressure, P_{3b} , at the top of compartment #3. Nevertheless, as will be discussed more in connection with experiment #4, a pressure gradient does appear to exist along the original z axis of compartment #3, but not due to the opening of the manhole cover. Both the "relieving" and "gradient" questions were of interest because certain opponents to a potential increase in manhole cover design pressure had argued that to keep the manhole cover intact was to risk excessive pressures which might rupture the tank walls. No significant tank shell failures were observed, although a one-inch split did occur at a weld seam which suffered severe folding-type distortions at the junction between the back head and the sidewall. This small failure was identical to those which had been seen on actual accident-involved vehicles, as discussed in Section 4.3.1.

Experiment #4 - In the last experiment, the previous conditions were repeated, but with only 3-percent outage space existing in each of the three tank compartments. The same 9,300-gallon tank vehicle was employed and was set up to be rolled over onto its opposite side.

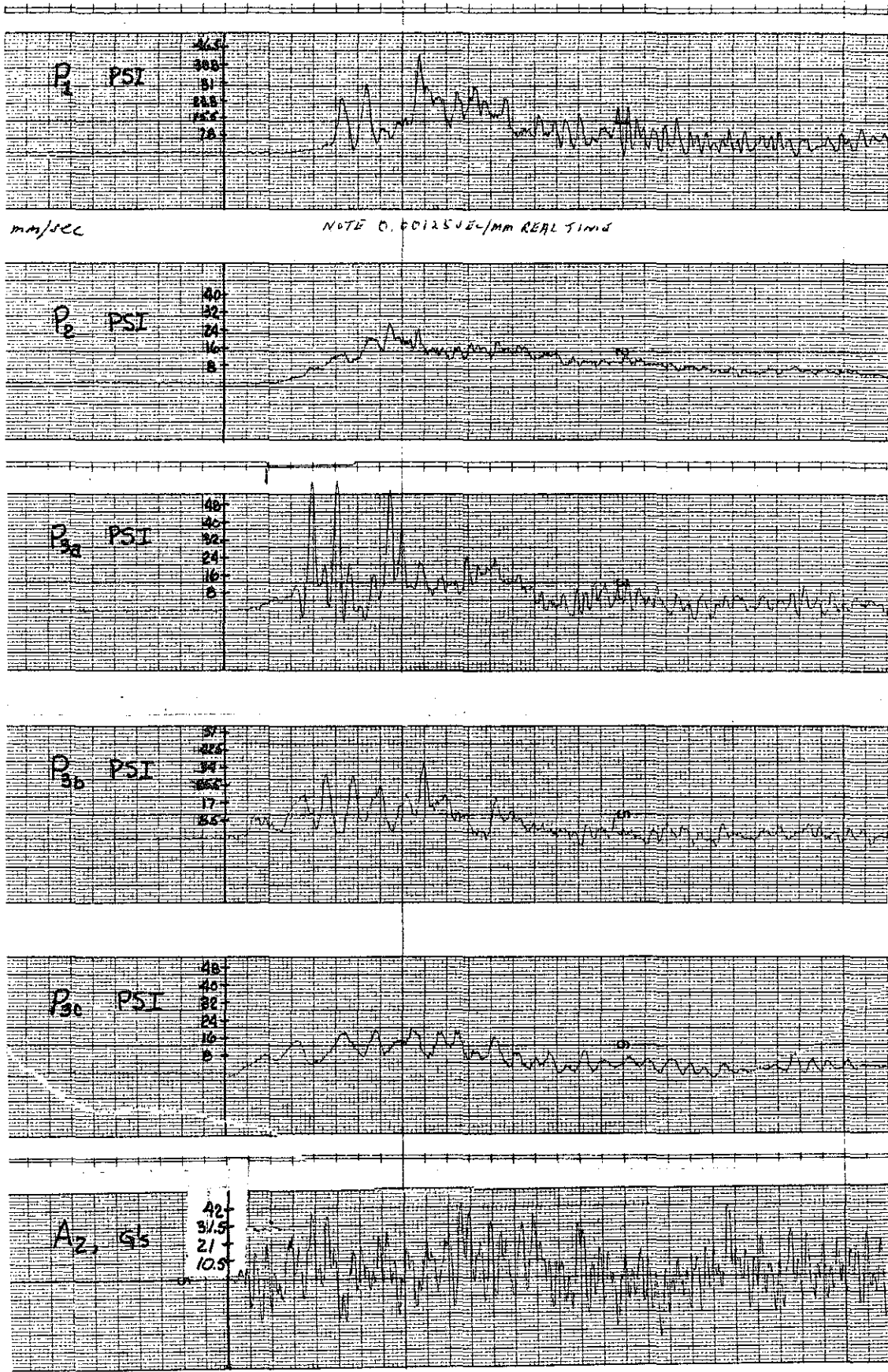

Figure 5.33. Recorded pressure and acceleration signals, from 3rd experiment, with 10% outage in the tank.

Sections of I-beam were welded to the previously flattened wall of the tanker to assure that the initial stiffness of the tank shell to internal pressure was obtained.

An additional pressure transducer was installed at the very bottom of compartment #3. Shown in Figure 5.34 is a sketch illustrating the full complement of pressure transducers employed in the fourth experiment.

Manhole covers monitored by transducers P_1 and P_2 were again blocked while the cast aluminum device was at position P_{3a} and a conventional clamp-ring device occupied position P_{3b} . Pressure transducers P_{3c} and P_{3d} were located to read gauge pressures prevailing at the mid-height and bottom of compartment #3, in line with the conventional clamp-ring-type manhole cover.

Upon rollover of the vehicle, the clamp-ring-type manhole cover was dislodged, as shown in Figure 5.35, and transducer signals were obtained as shown in Figure 5.36. The cast aluminum cover, with its minor modification, performed "perfectly"; that is, without residual leakage following the initial pressure surge at impact. We see that all of the pressures measured at the top of the tank (P_1 , P_2 , P_{3a} , and P_{3b}) showed a low frequency peak between 24 and 27 psi while all four of these signals contained high frequency spikes between 52 and 58 psi. The two signals measured at the middle and bottom of compartment #3 showed 20 psi and 16 psi low frequency peaks, respectively. Presumably, the attenuation of pressure level with position toward the bottom, along the original z axis, of the tank derives from a gradient reflecting an acceleration component oriented parallel to the ground. When the tank strikes the ground, there exists a horizontal component of velocity which becomes reduced toward zero upon generation of frictional forces between the tank shell and the pavement. The horizontal acceleration level can exceed 1 g since high normal forces are created by the high normal acceleration levels such as illustrated in the A_2 signal. Over the 8-foot height along the body-fixed z axis of this tank section, for example, a 20-g normal acceleration at impact will produce a 2-g

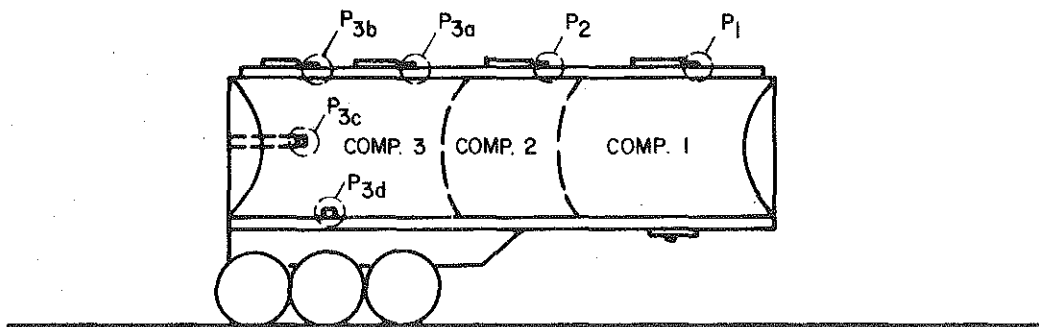

Figure 5.34. Tanker with pressure transducers set up for 4th experiment.



Figure 5.35. Moment of impact in the 4th experiment with clamp-ring-type manhole cover dislodging at far right. Note that the vehicle is reversed in this view, right/left, from the transducer layout diagram in Figure 5.34.

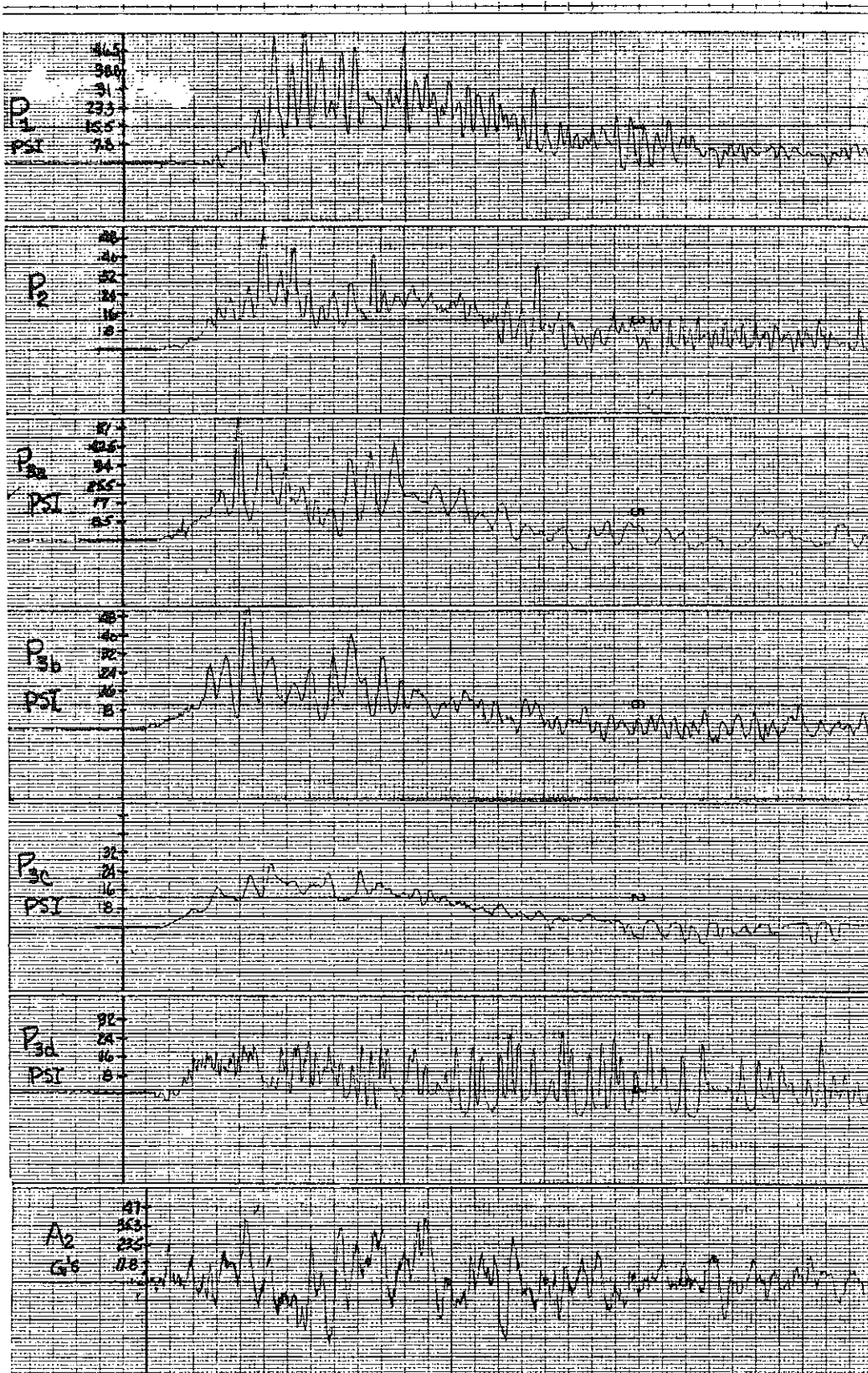

Figure 5.36. Time histories of pressure and acceleration measured in the 4th experiment with 3% outage in the tank.

horizontal acceleration and a 7-psi pressure drop from P_{3b} to P_{3d} , presuming a 0.1 frictional coupling between shell steel and pavement.

Overall, the fourth experiment showed significantly higher levels of the low frequency pressure component than were seen for the preceding test employing a 10-percent outage space.

Conclusions Drawn from Rollover Experiments

Insofar as the fluid employed in the foregoing tests was water, whose density is 8.3 lb/gal compared to 6.1 lb/gal for gasoline, the test measurements of the impact pressure applied to manhole covers are somewhat conservative, that is, somewhat higher than would derive if the load had been gasoline. Given that there are at least two major mechanisms contributing to impact pressures applied to manhole covers, however, the degree of conservatism cannot be easily determined. For example, if the only mechanism giving rise to internal pressure, at impact, was that of the bulk acceleration of the fluid mass, the pressures to be expected from the same volume of gasoline would be equal to the ratio of the fluid densities of gasoline versus water times the pressure level measured using water as the test fluid (viz., $\frac{6.1 \text{ lb/gal}}{8.3 \text{ lb/gal}} = 74$ percent of the water pressure level). The gasoline pressure would, in fact, be higher than the indicated 74 percent of water pressure levels, however, since it has been observed that the compression of the outage space due to tank deformation constitutes a major mechanism for generation of internal pressure at impact. Clearly, the outage space compression mechanism is simply determined by the Ideal Gas Law for an adiabatic process, and the volumes involved, and is thus insensitive to the density of the liquid product.

Accordingly, we conclude that the measured pressure levels can be looked upon as providing a reasonable, and somewhat conservative, estimate of impact pressures bearing upon manhole covers in the rollover of actual gasoline-transporting tankers of the type examined. The worst condition expected for simple tipover onto a rigid pavement entails, approximately, a 27-psi pressure pulse lasting on the order of 50 milliseconds, with 2-millisecond pulses reaching as high as 60 psi.

It is further observed that:

- a) one variety of conventional clamp-ring-type manhole cover becomes completely dislodged from the tank under the above pressure conditions,
- b) one currently available variety of cast aluminum manhole cover employing a reach-through type of tank fastening is seen to withstand the above pressure conditions without failure, and that
- c) even without dislodgement of a manhole cover, a substantial quantity of fluid is sprayed out through the 3-psi vent of each manhole cover, creating a highly diffuse mist that is presumably very easily ignited. The problems associated with this fluid loss have not been studied here, but are known to be currently under examination by the Bureau of Motor Carrier Safety of the U.S. Department of Transportation.

6.0 RISK OF TRANSPORTING GASOLINE

Analysis of accidents involving gasoline tankers in Michigan (see Section 3.1) has shown that tanker overturns are the cause of almost all of the gasoline releases and fires that occur. Indeed, the primary hazard involved in the transportation of gasoline can be reduced simply by adopting tanker configurations which minimize the number of rollovers each year. Accordingly, the risk which would accompany the use of each of the vehicle configurations considered in this study has been estimated in terms of the number of tanker rollovers/year that can be expected to occur if each of the particular vehicles were to be placed in general service for the transportation of gasoline throughout Michigan.

Several simplifying assumptions were made for the purposes of comparing the risks involved with each of the candidate vehicle configurations. Overall, the assumptions cover a sufficiently broad set of crucial factors that the estimate of the absolute level of risk is looked upon as rather crude. Nevertheless, the primary purpose for developing such an estimate is to obtain a measure of the ultimate safety quality of alternative vehicles such that a meaningful comparison can be made among vehicles. The important assumptions are described below.

1. The accident exposures of the candidate vehicle configurations are assumed to be inversely proportional to the payload volume of the vehicle; i.e., the larger the payload capacity of the vehicle, the fewer are the number of trips needed in transporting a fixed quantity of gasoline. The measure of exposure, L (in units of millions of loaded vehicle-miles/year) is given in the following expression:

$$L = \frac{V}{v} \times \frac{\ell}{10^6} \quad (27)$$

where

V is the annual consumption of gasoline in Michigan, gal/yr

v is the vehicle payload capacity, gal

and ℓ is the average length of the "loaded" trip, miles

2. The accident rate (in terms of accidents/million vehicle miles of exposure) is assumed to be approximately the same for all of the candidate vehicle configurations.

3. The effects of partial loading are not incorporated into the calculations of the risk numeric that is used for comparing the candidate vehicles. The increment in risk deriving from partial loading is taken to be common to all of the candidate vehicles, and hence, does not affect the comparison of the various vehicles relative to one another. An overall estimate of the risks deriving exclusively from the practice of partial loading is presented separately in Section 7.

4. The rollover threshold/rollover involvement relationship established using the BMCS accident data (in Section 3.2) is assumed to be valid for all types of roadways that are used by gasoline tankers in Michigan.

5. Each of the candidate vehicle configurations is considered as if it were the only vehicle type making up the entire fleet of gasoline tankers in the State.

A presentation of the steps involved in the estimation of the risks of operating each of the candidate vehicle configurations is organized under the following subheadings:

1. The total annual gallon-miles of gasoline transported by truck in Michigan.
2. The distribution of gasoline tanker travel by type of roadway.
3. The distribution of overall accident rates by type of roadway.
4. The distribution of accidents by type of impact (head-on, side-swipe, single-vehicle accident, etc.) for each type of roadway.
5. The incidence of rollover occurring as a result of the various types of accidents.
6. Final prediction of rollover risks.

We shall discuss each of these steps, in turn, in the sections which follow.

6.1 The Total Annual Gallon-Miles of Gasoline Transported by Truck in Michigan

-An estimate of the annual volume, V: Data on the monthly consumption of gasoline in Michigan [11] is shown in Figure 6.1 for the years 1960 through 1975. The figure shows the steady increase in the consumption of gasoline over the years, along with a seasonal variation in consumption during each year. The maximum consumption of gasoline occurs each year in July and the minimum consumption occurs in February. More recent data on the consumption of gasoline in Michigan was collected in 1978 during the double tanker study [2]. Both of the above data sources indicate that the current annual consumption of gasoline in Michigan is in the vicinity of 5.1×10^9 gallons/year. It is assumed that the seasonal variations in consumption, and thus tanker-miles, do not significantly skew the risk factors which are based, in this analysis, on the total volume of fuel transported over the entire year.

-An estimate of the average loaded trip length, L: A survey of the travel pattern of large gasoline and oil tankers was conducted during the double tanker study [2]. The survey revealed that, in Michigan, the average loaded trip length from the storage terminal to the delivery point was 25 miles.

6.2 The Distribution of Gasoline Tanker Travel by Type of Roadway

Data pertaining to the type of roadways traveled by gasoline tankers in Michigan was also collected during the double tanker study [2]. The percentage distribution of the total miles traveled by gasoline tankers on each roadway type is shown in Table 6.1.

The "urban roads" category in Table 6.1 includes the mileage traveled on both urban highways and city streets. Similarly, the "rural roads" category includes rural highways as well as county roads. Distinctions between these road types are needed, however, in order to make

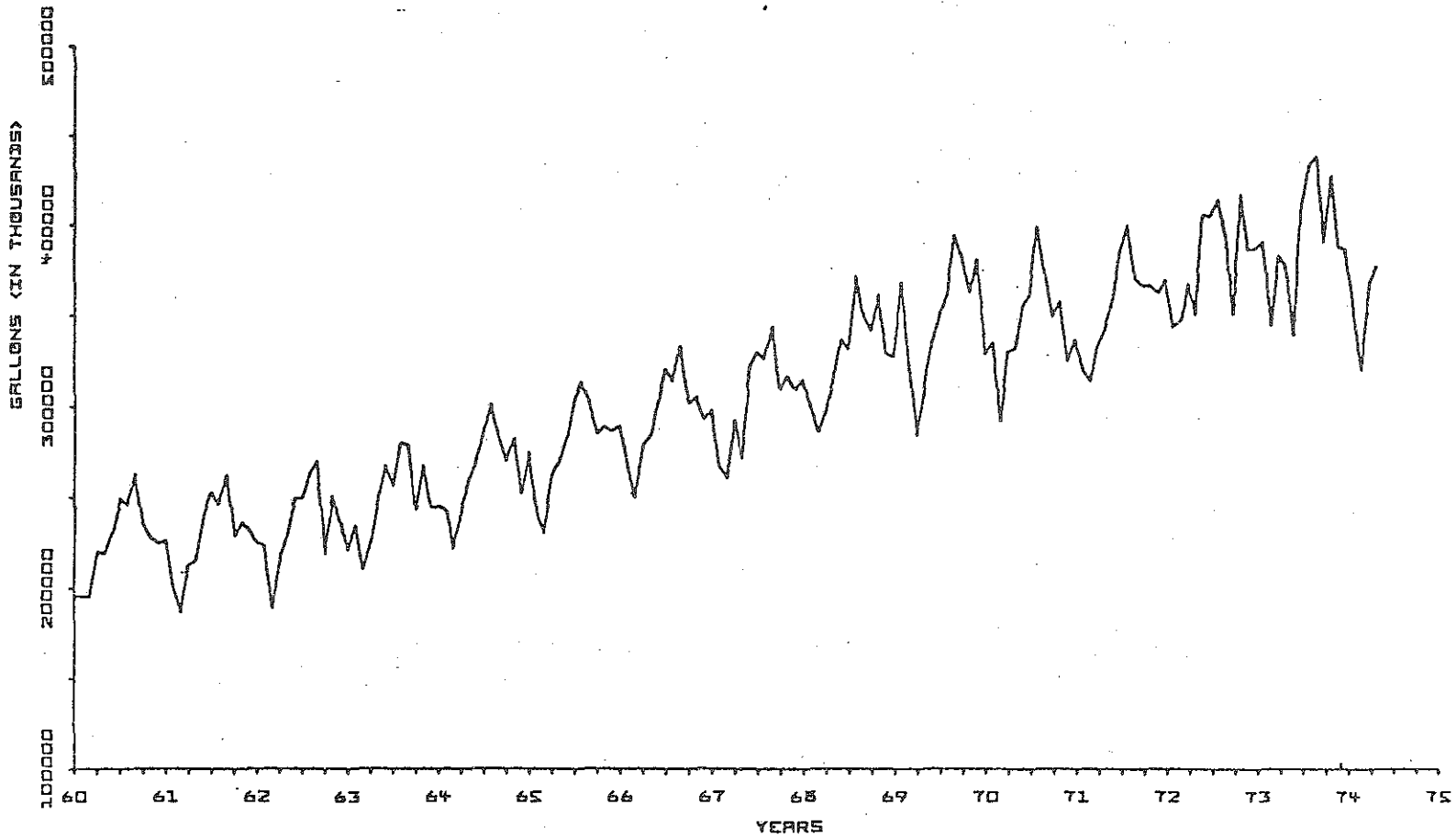

Figure 6.1. Monthly gasoline consumption in Michigan.

Table 6.1

<u>Road Type</u>	<u>% of Mileage</u>
Urban Freeways	28.3
Urban Roads	13.3
Rural Freeways	29.2
Rural Roads	29.2
Total	100.0

use of existing accident rate data. Lacking a base of data breaking down the "road" categories into "highway" and "city street" or "county road" components, it was assumed that 40 percent of the tanker mileage traveled on "urban roads" is on highways and 60 percent is on city streets. Of the mileage traveled on "rural roads," it is likewise assumed that 60 percent is on rural highways and 40 percent is on county roads. Upon incorporating the above assumptions, we obtain the distribution of mileage traveled by gasoline tankers in Michigan as shown in Table 6.2.

Table 6.2

<u>Road Type</u>	<u>% of Mileage</u>
Urban Freeways	28.3
Urban Highways	5.3
City Streets	8.0
Rural Freeways	29.2
Rural Highways	17.5
County Roads	11.7

6.3 The Distribution of Overall Accident Rate by Type of Roadway

The rate at which vehicles are involved in accidents is sensitive to the type of roadways on which they travel. For example, because of the fewer traffic conflicts that occur on freeways, accident rates are lower on freeways than on the other roadway types. Accident rate data published by the Michigan State Police [12] are shown in Table 6.3 for the years 1974-78. The accident rates are in the units of accidents/million vehicle miles. The data used to generate the accident rates shown in Table 6.3 contain accidents involving all vehicle types, a very large portion of which are passenger cars.

Table 6.3

Type of Road	1974	1975	1976	1977	1978	Average
Freeway	1.427	1.432	1.36	1.492	1.536	1.45
US & Michigan Highways	4.447	4.288	5.342	5.038	5.713	5.00
City Streets & County Roads	8.438	8.872	8.352	8.141	7.427	8.25

The overall accident involvement rate of trucks involved in petroleum transportation can be estimated from the annually published "Accident Facts" [13] of the National Safety Council (NSC). From 1976 to 1979, a sampling of some 40 to 61 petroleum transport fleets (the number of participating fleets varied from year to year) showed aggregate accident rates which averaged 5.25 accidents per million vehicle miles. Over the same years of reporting, the passenger car rate averaged 6.15 accidents per million vehicle miles. Thus, it was determined that the accident rates of petroleum distribution fleets could be conservatively estimated by using the lumped, passenger-car dominated, overall rates such as were listed in Table 6.3 from State Police files.

6.4 The Distribution of Accidents, by Type of Impact, for Each Type of Roadway

The expected number, N , of gasoline tanker accidents of a given collision type, A , which occur on a given roadway type, R , can be determined from the following equation:

$$N_{R,A} = L \times F_R \times A_R \times F_A \quad (28)$$

where:

L = total number of loaded vehicle miles (in millions) traveled by the gasoline tanker fleet in one year (Section 6.1)

F_R = fraction of the total travel that is done on roadway type R (Section 6.2)

A_R = accident rate, in units of accidents/million vehicle miles, on roadway type R (Section 6.3)

F_A = fraction of the total accidents that occur on roadway type R which are of the collision type A (Section 3.3)

For example, if we want to determine the number of single-vehicle accidents that can be expected to occur on rural highways for a total gasoline tanker exposure, L , of one million vehicle miles, it can be computed as follows.

We know that

$$F_R = .29 \text{ (Table 6.2)}$$

$$A_R = 1.45 \text{ acc/million vehicle miles (Table 6.3)}$$

$$F_A = 0.402 \text{ (Section 3.3)}$$

Therefore,
$$\frac{N_{R,A}}{L} = .169$$

The expected number of accidents for each of the six roadway conditions and each of the six accident types are listed in Table 6.4 for a gasoline tanker exposure of one million vehicle miles.

Table 6.4. Expected Number of Accidents for Each of the Roadway and Accident Types for a Total Gasoline Tanker Exposure of 1 Million Vehicle Miles.

Accident Type	Urban			Rural			Total
	Freeways	Highways	Roads	Freeways	Highways	Roads	
Single-Vehicle	.0595	.0339	.1346	.169	.2275	.304	.9285
Head-On	.0029	.00371	.0194	.0055	.0439	.0309	.1053
Rear-End	.1859	.1055	.2818	.1567	.3211	.2789	1.3299
Side-Swipe	.0702	.0318	.0544	.0474	.0665	.0714	.3417
Angular Impact	.0271	.0681	.14	.0144	.171	.246	.667
Multiple Vehicle	.0648	.0228	.02	.0296	.0438	.0314	.2219
Total	.4104	.2658	.6592	.4226	.8728	.9632	3.594

Table 6.4 indicates that gasoline tankers in Michigan can be expected to have an aggregate accident rate of 3.594 accidents/million vehicle miles of exposure. Of the various types of accidents, the largest percentage (37 percent) can be expected to be rear-end collisions, followed by single-vehicle accidents which account for about 26 percent of all accidents. Almost half of all the accidents can be expected to happen on rural highways and county roads.

The data in Table 6.4 will be used in the ultimate determination of tanker risk only as regards the incidence of single-vehicle accidents that are shown in the table. Single-vehicle accidents become the focal interest because, as will be shown below, rollover is predominantly a single-vehicle accident problem—and rollover constitutes the primary risk scenario for tankers carrying flammable liquids.

6.5 The Incidence of Rollover Occurring as a Result of Various Types of Accidents

One can appreciate, even on an intuitive basis, that the likelihood of rollover is not the same for all types of accidents. For example, a gasoline tanker is less likely to roll over as a result of an accident in which it is hit from the rear by a passenger car, as compared to an accident in which the vehicle runs off the roadway.

Three sources of accident data were investigated with the aim of quantifying the extent to which single-vehicle accidents are responsible for the incidence of rollover. The accident data sources included (1) Michigan State Fire Marshall data for the years 1978 and 1979; (2) FARS data for the years 1978 and 1979; and (3) tractor/semitrailer accidents in the United Kingdom for the period 1971-73.

State Fire Marshall Data: The Michigan State Fire Marshall data has been described in Section 3.1. Of the 27 gasoline tanker overturns analyzed, 22 (or 81 percent) were found to be the result of single-vehicle accidents. Despite the fact that collision accidents contribute a large portion of the total accidents that occur each year, they account for only 5 (or 19 percent) of the gasoline tanker rollovers.

Since the size of the data set is small, however, the percentage figures given above can only be taken as a rough estimate of the fraction of rollovers that result from single-vehicle and collision-type accidents.

FARS accident data: FARS (Fatal Accident Reporting System) constitutes a computerized file of accident data, maintained by the National Highway Traffic Safety Administration (NHTSA) and contains information on fatal motor vehicle traffic accidents occurring in the U.S. Accidents involving truck-tractors pulling semitrailers were extracted from this data set. The examined data were restricted to only those accidents which resulted in the fatality of a truck occupant. The data showed that, in 1978, there were 486 rollovers which resulted in a fatality to the truck occupant and in 1979 there were 533 such rollovers. The rollover data is shown broken down into single-vehicle and collision rollovers in Table 6.5. We see that the FARS data confirm

Table 6.5

	1978		1979	
	No.	%	No.	%
Single-Vehicle Rollover	391	80	437	82
Collision Rollover	95	20	96	18
Total	486	100	533	100

the finding obtained from the State Fire Marshall data; namely, that 80 percent of the rollovers are due to single-vehicle accidents, while accidents which involve a collision with another vehicle account for only 20 percent of the rollovers.

Tractor/semitrailer accidents in the U.K.: Fatal and injury-producing accidents occurring in the United Kingdom were analyzed by the Transport and Road Research Laboratory (TRRL) of the United Kingdom. Results of the analysis of accidents which involve articulated vehicles were reported in Reference [14]. Table 6.6 shows the rollover involvement of articulated vehicles for the years 1971-73.

Table 6.6

	1971	1972	1973	Total	Percent
Single-Vehicle Accidents	186	166	208	560	77
Collision Accidents	64	62	44	160	23

From the percentage distributions seen in the right-hand column, we conclude that the U. K. data, as well as that deriving from the two previously described data sources, support the conclusion that tractor-semitrailer rollovers are primarily a single-vehicle accident phenomenon. In the calculations that follow, we have therefore assumed that 80 percent of the gasoline tanker overturns occur as a result of single-vehicle accidents while the remaining 20 percent are due to accidents which involve a collision with another vehicle.

6.6 Final Prediction of Rollover Risks

The expected number of gasoline tanker rollovers which would result from the adoption of a particular tanker design in Michigan is influenced by (1) the rollover threshold of the vehicle and (2) the payload capacity of the vehicle.

An estimate of the number of rollovers, N , that can be expected to happen in a year, given the exclusive use of each of the candidate vehicles, can be determined from the following equation:

$$N = L \times \left[p_{SV} \times P_{R/SV} + \sum_{i=1}^5 p_{col_i} \times P_{R/col_i} \right] \quad (29)$$

where

L is the exposure associated with a vehicle of payload volume, v (millions of vehicle miles)

p_{SV} is the single-vehicle accident rate (accidents/million vehicle miles)

P_{col_i} is the collision accident rate for a collision of type i (accidents/million vehicle miles)

$P_{R/SV}$ is probability of rollover in a single-vehicle accident

P_{R/col_i} is probability of rollover in a collision of type i

If the steady turning rollover threshold of a candidate vehicle is known, the probability of a rollover in a single-vehicle accident ($P_{R/SV}$) can be determined from the rollover threshold/rollover involvement relationship which was established using the BMCS accident data in Section 3.2. The influence of rollover threshold on the probability of rollover during accidents which involve a collision with other vehicles (P_{R/col_i}) cannot be determined from existing data. Nevertheless, the analysis in Section 6.5 has revealed that single-vehicle accidents account for approximately 80 percent of all tractor-semitrailer rollovers that take place each year. Therefore, an estimate of the total number of rollovers to be expected in one year has been derived using a modified form of Equation (2), as shown below:

$$\begin{aligned} N &= L \times P_{SV} \times \frac{10}{8} \times P_{R/SV} \\ &= L \times P_{SV} \times P_{R/SV} \end{aligned} \quad (30)$$

where $P_{SV} = p_{SV} \times \frac{10}{8}$ constitutes a pseudo-single-vehicle accident rate that accounts for the collision accidents term, P_{col_i} that appeared in Equation (29).

From Table 6.4, we know that $p_{SV} = 0.9285$ accidents/million vehicle miles. Therefore

$$P_{SV} = .9285 \times \frac{10}{8} = 1.1606 \text{ acc/million vehicle miles}$$

Hence, Equation (3) can now be used for computing the expected number of gasoline tanker rollovers which would occur per year as the result of a hypothetically exclusive usage of each of the candidate vehicle configurations. Listed in Tables 6.7 and 6.8 are the payload capacity, exposure, rollover threshold, probability of rollover in a single-vehicle accident, expected number of accidents per year and the expected number of rollovers per year for each of the examined tractor-semitrailer and TSS combinations, respectively. The expected number of rollovers per year are plotted as a function of vehicle payload volume in Figure 6.2. The expected number of rollovers for a conventional 8,800-gallon tanker, which meets the MC306 specifications, is also shown superimposed on this figure.

The four recommended vehicles are seen to range, in predicted number of rollovers per year, from 4.06 to 4.45, while the reference MC306 tanker shows a value of 8.608, i.e., approximately twice as high a total incidence of rollover.

The total projection of 8.6 rollovers/year with a fleet of conventional MC306 tankers can be compared with Michigan's actual experience of 15 gasoline tanker rollovers in 1978 and 12 in 1979. The fleet in 1978 was comprised largely of doubles which accounted for two-thirds of the rollovers. In 1979, a much greater fraction of the fleet was of the single-trailer configuration, such that singles accounted for three-fourths of the rollovers. Given that many of the singles running in Michigan in 1979 were of the same nominal capacity as the typical MC306 tankers, but with higher centers of gravity, a projection of 8.6 appears to be in reasonable harmony with the actual rollover frequencies recently experienced. Moreover, the absolute rate at which rollovers will occur is not so significant to the evaluation of the recommended tanker configurations as is the relative risk posed by the recommended vehicles versus the typical MC306 variety.

Finally, shown in Figure 6.3 is a plot of the simple hyperbolic relationship existing between the annual number of accidents of all kinds which would be encountered as a function of tank payload volume. We see that the larger volume tank vehicles offer large reductions in overall accident involvement simply by the reduction in vehicle-miles of exposure.

Table 6.7. Tractor/Semitrailer Combinations

Config. #	Payload Capacity v	Exposure Veh. Mi. $\times 10^6$ /Yr. L	Rollover Threshold g's	$P_{R/SV}$	Expected # Acc./Yr.	Expected # Rollovers/Yr $L \times P_{SV} \times P_{R/SV}$
1	8,090	15.76	0.402	.335	56.6	6.13
2a	8,730	14.61	0.408	.322	52.5	5.46
2b	10,833	11.77	0.385	.382	42.3	5.22
3a	10,210	12.49	0.414	.307	44.9	4.45
3b	10,920	11.68	0.403	.335	42.0	4.54
4a	11,700	10.90	0.406	.33	39.2	4.18
4b	12,400	10.28	0.394	.36	36.9	4.30
5a	13,180	9.67	0.393	.362	34.8	4.06
5b	13,880	9.19	0.383	.38	33.0	4.05
6	14,670	8.69	0.382	.392	31.2	3.96
7	16,150	7.89	0.369	.417	28.4	3.82
MC306	8,800	14.5	0.34	.512	52.1	8.608

Table 6.8. Tractor/Semitrailer/Semitrailer Combination

Config. #	Payload Capacity v	Exposure Veh. Mi. x 10 ⁶ /Yr. L	Rollover Threshold g's	P _{R/SV}	Expected # Acc./Yr.	Expected #
						Rollovers/Yr.* L × P _{SV} × P _{R/SV}
I	10,620	11.9	.45	.235	43.1	3.27
IIa	12,110	10.53	.433	.27	37.8	3.30
IIb	13,100	9.73	.400	.341	35.0	3.86
III	13,590	9.38	.421	.294	33.7	3.20
IVa	12,110	10.53	.455	.225	37.8	2.75
IVb	13,100	9.73	.422	.292	35.0	3.29
V	13,590	9.38	.444	.245	33.7	2.67
VI	14,570	8.75	.408	.322	31.4	3.27
VII	16,060	7.94	.398	.35	28.5	3.23

*Please note that the expected rollovers/year for TSS combinations have been calculated solely on the basis of the P_{R/SV} probabilities deriving from the steady-state rollover thresholds. Other rollover or collision problems deriving from lower dynamic rollover thresholds or poor high-speed offtracking performance have not been accounted.

59' Tractor/Semi/
Semi
65' Tractor/Semi/
Semi

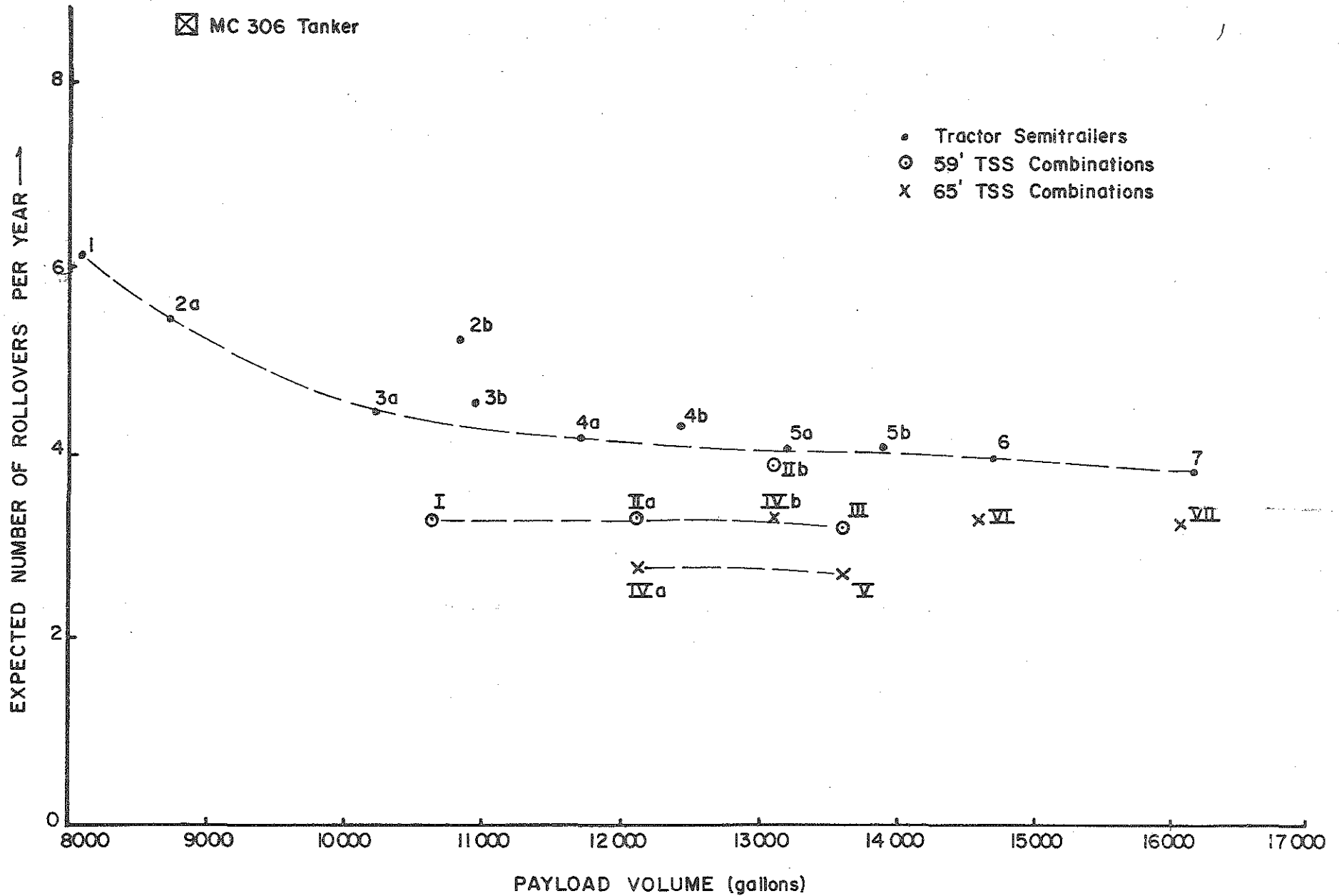

Figure 6.2. Expected number of rollovers/year for each of the candidate vehicle configurations.

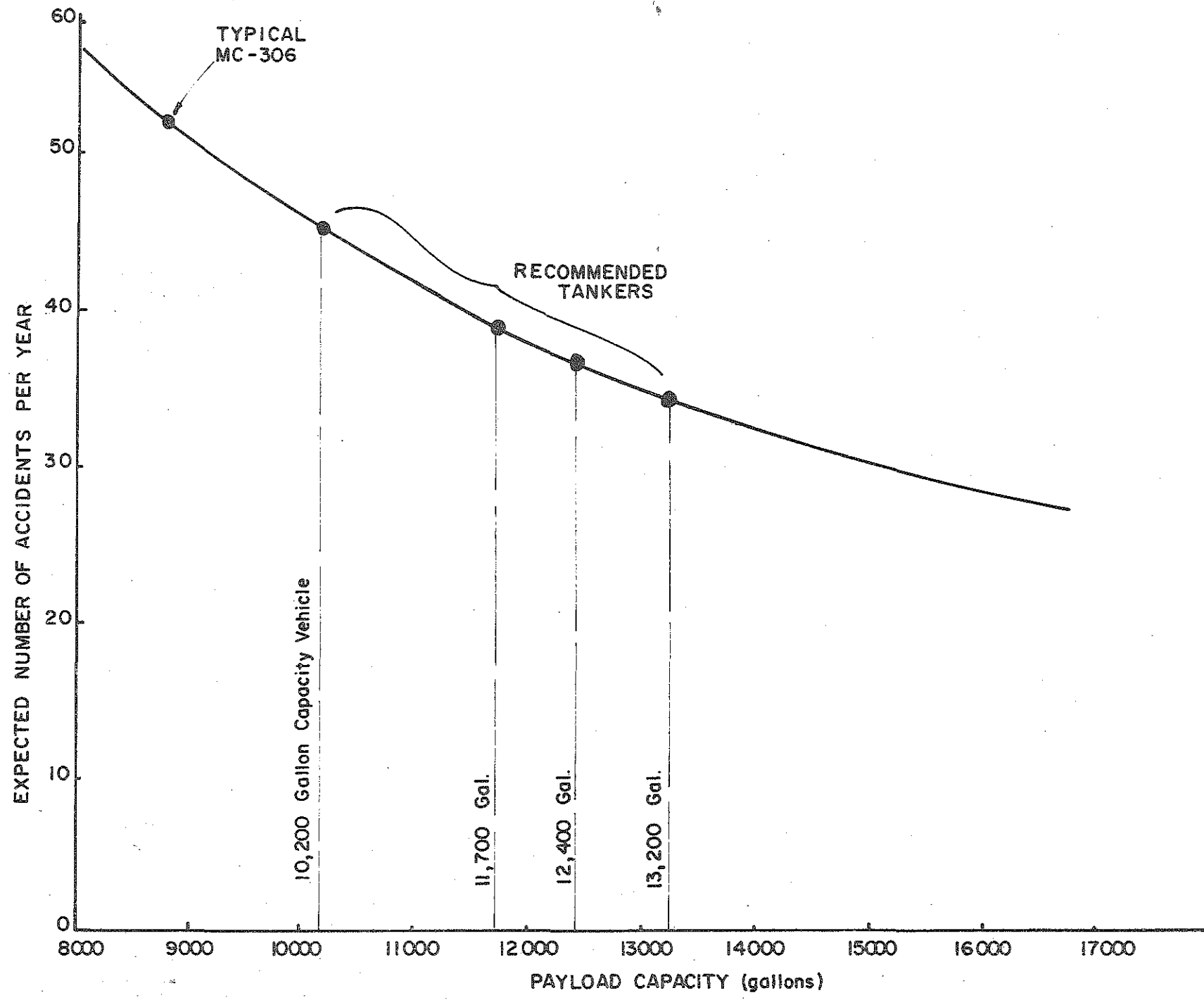

Figure 6.3. Overall accident involvement as a function of the payload volume of the tankers.

7.0 INCREMENT IN RISK DERIVING FROM SLOSH

Although slosh has a negative effect on the tanker rollover limits, the appropriateness of any countermeasures is best judged on the basis of its effect on accident statistics. For example, simply outlawing partial compartment loading could result in more vehicle exposure as the available compartments would have to be used more selectively. Alternatively, more compartmentalization or baffeling would be required at the expense of additional complexity and higher initial costs. Therefore, an analysis of the expected accident experience was performed. The purpose of the analysis was to estimate the increase in rollover accidents expected if slosh loading is allowed with the new tanker designs. A three-step method was employed:

1. Determination of representative loading patterns with Michigan gasoline tankers today.
2. Application of that pattern to a typical new configuration tanker to determine the net effect on rollover limits.
3. Estimating the difference in frequency of rollover accidents which would occur if slosh loading were permitted in contrast to its being prohibited.

7.1 Gasoline Loading Patterns

The field survey of tanker operations in the State of Michigan performed in the previous study [2] documented 208 tanker trips hauling gasoline, of which 38 involved loads satisfying the "slosh criterion" as a result of fluid occupying between 20 and 80 percent of the compartment volume within one or more compartments. These trips involving sloshing loads represented 775 miles out of a total of 5400 miles of gasoline haulage reported in the survey. Hence it is inferred that 13 percent of the gasoline hauling mileage occurs under the defined sloshing condition.

The loading pattern for each trip involving slosh was analyzed to determine the load as a percentage of the total capacity, and the percentage of the compartments in the fill range of 20 to 80 percent. The load carried on slosh trips ranged from 34 to 99 percent of capacity (4,000 to 15,000 gallons). The percentage of load that was free to slosh ranged from as little as 6 percent of the fluid in the tank (700 gallons) to 100 percent (7,500 gallons).

7.2 Effect on Rollover Threshold

The specific effect of a slosh load on rollover threshold is dependent on the vehicle and the maneuver. Hence it is only possible to estimate the relative significance of these operating conditions for given vehicles. Since the purpose of this analysis is to assess the importance of the slosh problem with the future tanker configurations, the 13,200-gallon tanker has been used. Though other tanker configurations have been recommended also, all have similar rollover thresholds such that the relative significance of slosh loading with each tanker would be quite like that determined for the 13,200-gallon vehicle.

The type of maneuver used in the assessment must also be duly considered. A liquid tanker can be characterized by three types of rollover threshold, as discussed earlier in Section 4.3.1, namely:

- 1) The steady-state cornering limit,
- 2) the step-steer cornering limit where the "liquid" pendulum is assumed to overshoot its final (steady-state) position by a factor of two, and
- 3) the transient (lane-change) maneuver limit where the liquid moves first one way and then the other with a severity that depends upon the nominal period of the reversing motion.

Much of the risk analysis in this study has been built on the observed relationship between the frequency of rollover in single-vehicle accidents and the measure of steady-state rollover threshold. A prediction of risk based upon the steady-state rollover limit of tankers having

unrestrained liquids, however, would fail to reflect fully the dynamics peculiar to these vehicles. On the other hand, a prediction of risk based upon lane-change performance limits would appear unrealistic because of its dependence on fluid resonance in the maneuver. Accordingly, the step-steer rollover limits, seen previously in Figure 4.55, were selected as a suitably conservative basis for estimating the relative effect of sloshing loads on the aggregate risk of transporting gasoline.

Each of the 38 load patterns identified previously as satisfying the slosh criteria were evaluated using Figure 4.55, at the applicable percentages of total load, to determine the estimated rollover limit for each of two cases; namely,

- 1) with slosh - the limit was determined based on the actual percentage of the compartmental capacity that was loaded in a slosh condition, and
- 2) without slosh - the limit was determined for the same total load percentage at the zero slosh line.

The first case represents the typical performance limit that would be obtained if no slosh countermeasures were employed and a comparable loading practice was used with the future tanker configuration. The second case reflects the improvement in rollover limit that would accrue from eliminating the slosh condition by means of some mechanical countermeasure. By averaging over all the load patterns, then, an estimate of the average rollover limits with and without slosh is obtained.

With slosh, an average rollover threshold of 0.374 g's was obtained (with values ranging from 0.295 to 0.43 g's). Considering that the fully loaded vehicle has a rollover threshold of 0.393 g's, it is evident that the average slosh-loaded vehicle is actually worse than a fully loaded vehicle.

Without slosh, an average rollover threshold of 0.424 g's was obtained (with values ranging from 0.396 to 0.501 g's). This higher threshold reflects an improvement in vehicle performance obtained at partial loading when slosh is avoided.

Although partial loading represents a less efficient transport mode with more accident exposure per gallon-mile of fuel movement, operation without slosh compensates to some extent by capitalizing on the improved performance possible at lighter loads. On the other hand, operation with slosh not only increases exposure, but does so with a vehicle compromised by a lower performance capability.

7.3 Estimated Rollover Accident Frequency

The degree of significance that can be applied to the above results is best judged by estimating the impact of the slosh condition on accident frequency. It is assumed here that slosh, in itself, is not an accident causative factor except as an influence on rollover. That is, we assume that the presence of unrestrained liquid in the tanker does not influence the frequency of driving conflict situations leading to accidents,* but does influence the frequency of rollovers in these situations.

The reduced rollover thresholds cited above as applying to slosh-loaded cases can be translated into meaningful estimates of accident frequency on the basis of the relationship, developed in Section 3.2, between rollover frequency in single-vehicle accidents and the estimated rollover threshold.

Using the previously-described survey data, with 13 percent of tanker mileage accrued with a partial load, the overall equation (30) for prediction of rollover risk can be written as:

$$N = .13L \times P_{SV} \times P_{RP/SV} + .87L \times P_{SV} \times P_{R/SV} \quad (31)$$

*This assumption is a little weak in that drivers may be less willing to take effective evasive action with a sloshing load. Nevertheless, no data exists by which to estimate this effect.

where

- P_{SV} = single-vehicle accident rate (acc./mile)
- $P_{RP/SV}$ = probability of rollover in a single-vehicle accident for the partially loaded vehicle
= .41 for partially loaded vehicles with slosh (rollover limit = 0.374 g's)
= .285 for partially loaded vehicles without slosh (rollover limit = 0.424 g's)
- $P_{R/SV}$ = probability of rollover in a single-vehicle accident for the fully loaded vehicle (rollover limit = 0.393)
= .362
- L = load miles traveled by a complete fleet of 13,200-gallon tankers
= 9,670,000 miles

Using the above relationships, the total annual number of rollovers occurring with slosh loading permitted would be calculated as:

$$N = 4.13 \text{ rollovers/year}$$

If the slosh condition is prevented by means of a totally effective countermeasure, the total annual number of rollovers would be

$$N = 3.95 \text{ rollovers/year}$$

Hence, the effect of slosh loading would be to increase accident frequency by .18 rollovers/year, or roughly, one rollover every 5 years. This influence has been deemed sufficiently small from the viewpoint of overall accident production that no countermeasure has been recommended for inclusion in Michigan legislation. Nevertheless, certain other concluding remarks are in order. It is important that tank transport operators and dispatchers understand that dramatically increased risks accompany the operation of individual vehicles having significant amounts

of slosh loading, as outlined previously. In the worst cases, such as when the tank is half full and all compartments are involved in the partial-fill condition, any fairly rapid steering motion or run-off-road event is highly likely to produce a rollover. Thus, while various practical considerations argue strongly against recommending a regulation to prevent the slosh problem, it should not be construed that the authors see the slosh issue as "no problem."

8.0 CONSIDERATIONS RELATED TO THE TILT-TABLE REQUIREMENT

Tilt-table facilities have been employed for measurement of vehicle rollover stability levels in Germany [6], England [14], and Sweden [15]. The rollover stability of English buses has been regulated by means of tilt-table tests for a number of years and the development of such regulations has been proposed in both Sweden and Australia [16]. The tilt-table approach to assessing the compliance of Advanced Michigan Tankers has been chosen as the simplest means of specifying performance without unduly constraining the details of vehicle design. In this section, the tilt-table test, itself, will be discussed, as will the considerations which led to the specified tilt-table angles that are recommended for regulation.

8.1 The Tilt-Table Test

When a vehicle is cornering at its rollover limit on a flat, horizontal surface, it experiences the nominal tire and centripetal force loadings diagrammed in Figure 8.1. By contrast, a vehicle subjected to a tilt-table experiment experiences a somewhat different set of loads, as shown in Figure 8.2.

As shown, a higher resultant force at the tire-road interface is achieved with the vehicle in an actual cornering maneuver than with the vehicle on the tilt-table. Also, a higher net loading of the vehicle's suspension is experienced in the actual cornering case since the full weight of the vehicle is still being supported along the nominal line of action of the suspension springs. Computer simulation of both the cornering and tilt-table cases, however, has established that, for a heavy vehicle such as the tankers studied here, the tilt-table-derived rollover threshold is approximately 2 percent higher than the rollover threshold which is found from a steady cornering maneuver. Thus, with the excellent agreement achieved between computed tilt-table results and reported tilt-table tests (see Section 4.1.3), the computer-derived tilt angle limits are seen as a sound basis for specifying the rollover thresholds of the recommended tankers.

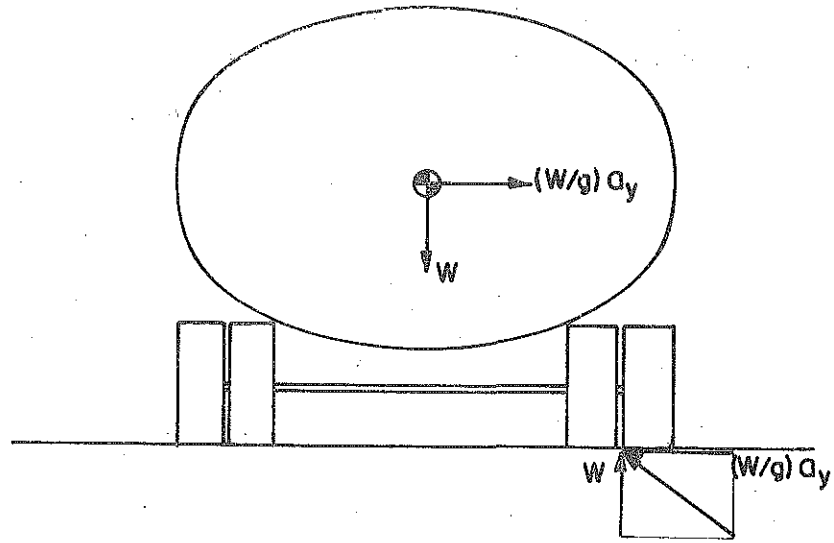

Figure 8.1. Loads experienced during cornering.

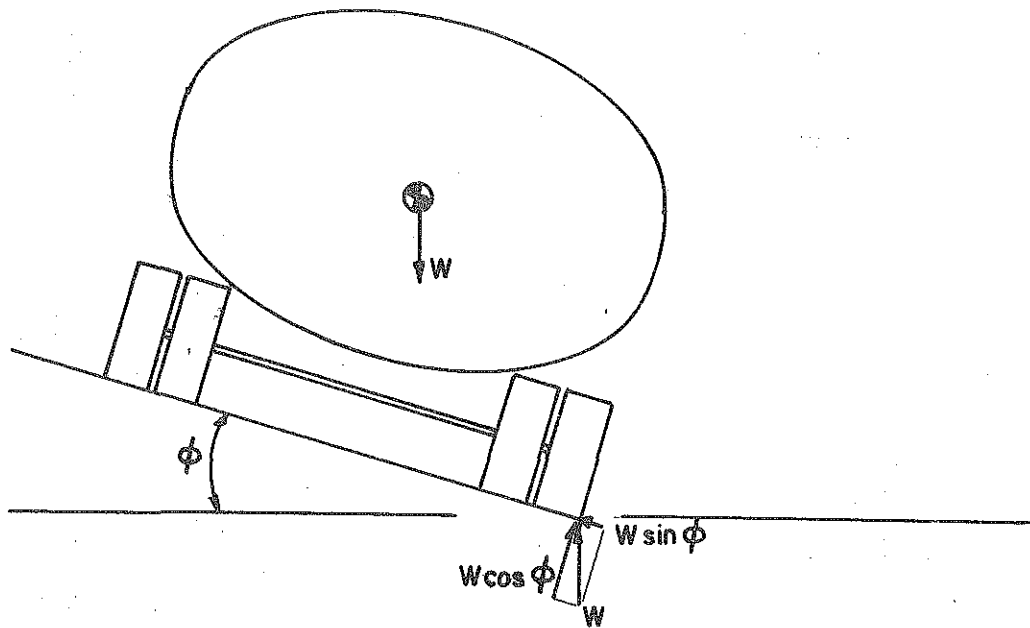

Figure 8.2. Loads experienced on a tilt-table arrangement.

An actual device for conducting the limit tilt angle measurement can be constructed in a number of ways. Among the English, German, and Swedish facilities are hydraulic and mechanical jacking mechanisms which actuate tilt plates comprising either a collection of individual support beams, with one under each axle, or a single heavy table long enough to accommodate the entire vehicle. The existing devices have been of both the fixed and portable variety.

Regardless of the specifics of table design, there are at least five features which a tilt-table facility must provide; namely,

1. A structure capable of supporting the vehicle without introducing tilt angle differences exceeding ± 0.1 degree from axle to axle.
2. A single hinge about which the table pivots.
3. Actuation elements capable of rotating the table through the tilt angles of interest.
4. A means for measuring tilt angle.
5. A mechanism for tethering the vehicle so that, upon finding the rollover threshold, the vehicle's ensuing roll motion is restrained.

The tilt angle test is conducted with the vehicle fully loaded. Insofar as a gasoline load would pose unnecessary risks for such experiments, it is presumed that the preferred fluid would be Stoddard's solvent, a liquid having very nearly the same density as gasoline, but characterized by a flash-point which is well above that of gasoline. A full load of such solvent could be "rented" from a bulk supplier for the few hours required for conducting the tilt test.

Having situated the subject vehicle on the tilt-table, the table is raised slowly until a point is reached at which the vehicle continues to increase its roll angle without further table inclination. A table rate of 0.1 deg/sec in the vicinity of the limit angle should be slow enough to permit ready observation of the beginning of vehicle roll instability. The roll-unstable point will be observed rather near to





the tilt angle condition at which trailer tires have lifted off of the table, but probably before the up-side tire on the tractor's steering axle has lifted off. Since the recommended tilt angle limits are in the vicinity of 22 degrees, there will be no problem with "slippage" of the vehicle's tires on the table surface as long as a reasonably gritty or textured finish is attained.

Aside from the above considerations, there may arise an interest, among vehicle manufacturers, in simplified means of assuring that vehicles comply with a specifically required level of tilt-table angle performance. In such cases, no measurement of the limit capability is needed, but rather the need is simply to subject the vehicle to the required inclination angle to determine whether or not a stable condition prevails. For such a purpose, a paved slope might be prepared permitting one to drive the subject vehicle up onto the slope in the empty condition, and then to conduct the test by filling the tank, in situ. By such a scheme, of course, tethering would still be needed to prevent a rollover from actually occurring. In fact, it might be necessary to more tightly tether the vehicle during the filling process and then, subsequently, to relieve the tether to test for roll stability since it is possible that the laterally-shifted mass center occurring at some intermediate fill condition will prematurely destabilize the vehicle. Following such a fixed-slope test, the tank could, again, be emptied for removal of the vehicle.

8.2 Tilt-Table Performance Requirements

Listed in Table 8.1 are tilt-table angles at which rollover has been calculated to occur for representative examples of each of the four Advanced Michigan Tanker vehicles. Also shown are the tilt-table rollover angles which constitute the recommended requirements for the four respective configurations. The reader will note that the recommended requirements have been set lower than the expected levels of performance capability for each vehicle. Such an "allowance" has been based on certain observations regarding the inaccuracy of the calculation method, as well as philosophical considerations regarding the setting of

Table 8.1

SCHEMATIC DIAGRAM	DESIGN VOLUME (gallons)	TILT TABLE ROLLOVER ANGLE (deg)	
		Calculated	Specified
	10,200	22.5	21.5
	11,700	22.0	21.0
	12,400	21.5	20.5
	13,200	21.5	20.5

performance requirements to attain operational safety. Sources of both real and potential inaccuracies in the calculations of ϕ_T are given below.

1. The tilt-table angle equivalent of the rollover thresholds for each of the four recommended vehicle configurations were computed using a horizontal plane, steady-turning-type calculation of the rollover limit. By this method, the equivalent tilt-table angle, ϕ_T , is defined by the expression

$$\phi_T = \tan^{-1} \frac{A_{yc}}{g}$$

where A_{yc} is the steady turn rollover threshold that was simulated. Additional calculations have shown that, due to trigonometric factors, the value of ϕ_T that is determined by this approach is approximately 0.5 degree lower than the value which can be achieved by the subject vehicle if actually taken to its rollover threshold on a tilt-table. Thus, the calculated tilt-table rollover angles are approximately 0.5 degree lower, because of the calculation method, than the limit tilt angle capabilities that should be expected for each of the four recommended vehicle configurations.

2. The reference calculations included a hypothetical tractor which was representative of tractors in normal line-haul service with 80,000-lb gcw combinations. This vehicle introduces an approximate 0.5-degree reduction in the calculated tilt angle capability of each tanker compared to the tilt angle which might be attained using a heavier tractor such as would be more typically employed in combination with the higher-gcw tankers. The simulated tractor was represented with:

- a) a four-spring tandem suspension having 1-1/2 inches of lash space as opposed to a lash space dimension of 3/4 inch, which would typify the walking-beam suspensions more commonly found pulling high gross weight trailers

- b) suspension spring rates which were, perhaps, 30 percent lower than might be commonly found on tractors suited to the higher gcw combination.

Accordingly, the "calculated" limit tilt angles can be looked upon as containing an additional 0.5 degree margin below the values which are possible with heavier tractor suspensions.

3. It has been assumed that the two mechanisms influencing the development of overturning moment on the outermost tire on each axle are equal to one another in magnitude and of opposite polarity, such that they cancel one another. As had been shown earlier in Figure 4.15, these two mechanisms are (1) the overturning moment due to the inboard translation of the vertical load center deriving from the lateral compliance of the tire and (2) the overturning moment due to the outboard translation of the vertical load center deriving from inclination of the wheel plane. While only very limited measurements on one truck tire have been made to confirm this assumption, more extensive data on car tires [17] show that a rather complex trade-off exists between the two mechanisms cited above. Further, it may be that some differences in the overturning moment mechanisms may occur between bias- and radial-ply tires. Accordingly, the projection of limit tilt-table angles contains some uncertainty as regards the role played by the tire. We estimate that variations in the actual limit tilt-table angle deriving from errors in simulating these mechanisms could be as large as ± 0.25 degree.

4. The existence of free play in the fifth wheel coupling between tractor and semitrailer was neglected in computer calculations of limit tilt-table angles. A limited set of measurements on actual vehicles has shown that fifth wheel free play involves an included angle between the tractor and trailer sprung masses that is as large as 2.5 degrees. Calculations show, however, that for a reasonably stiff trailer suspension, the fifth wheel free play will be encountered at roll angles just beyond those occurring at the limit tilt-table angles recommended for the advanced tankers. Thus, while it is not anticipated that fifth wheel free play will influence the tilt-table performance of most vehicles, it is possible that a given manufacturer's design parameters could so adjust

behavior away from the cases represented in our calculations that fifth wheel free play might be encountered, thereby significantly lowering the limit tilt-table angle performance. Having cited fifth wheel free play as a potential issue in determining a given vehicle's tilt-table performance, we do not identify this free play mechanism as a source of inaccuracy in the calculations.

The nature of vehicle performance regulation is such that manufacturers wish to build vehicles sufficiently exceeding the required performance capabilities that the risk of non-compliance is minimized. Thus, it would be unreasonable to write a regulation which requires the maximum level of performance of which vehicles are thought to be capable. Such an approach allows the manufacturer no margin for assurance of compliance. Accordingly, it was determined that the setting of limit tilt-table angles should include a margin, permitting manufacturers to build to exceed the performance level needed for compliance. The trade-off consideration that argued for minimizing the "margin" discussed above is that the lower the limit tilt-table requirement, the greater is the risk of rollover of the regulated tankers. Given the nominal rollover thresholds characterizing the four recommended tank vehicles, a one-degree reduction in the tilt-table angle requirement suggests that the rollover risk increases by approximately 0.6 rollovers per year.

On the basis of the above considerations, the recommended levels of limit table angle were reduced below the "calculated" levels by one degree, thus providing vehicle manufacturers with an effective margin of 1.75 to 2.25 degrees given that:

- a) the calculation method provided an approximate 0.5-degree under-estimate of the actual tilt-table limit angle for each recommended vehicle,
- b) tractors with the suspension properties accompanying a suitably tailored gcw rating are expected to be the norm, providing an additional 0.5-degree margin above the originally calculated level, and

- c) the cited tire mechanisms could bring about as much as a ± 0.25 -degree alteration in limit tilt angle performance with respect to the calculated numbers.

REFERENCES

1. Federal Highway Administration, U.S. Department of Transportation. "Oversized Vehicle Study." Surface Transportation Assistance Act of 1978, Section 211. September 1979.
2. Ervin, R.D., et al. "Ad Hoc Study of Certain Safety-Related Aspects of Double-Bottom Tankers." Final Report, Contract No. MPA-78-002A, Sponsored by Office of Highway Safety Planning, Michigan Department of State Police. Highway Safety Research Institute, The University of Michigan, Report No. UM-HSRI-78-18, May 7, 1978.
3. Truck Trailer Manufacturers Association. "Van Trailer Size Survey -- 1978." July 1979.
4. Rhoads, R.E., et al. "An Assessment of the Risk of Transporting Gasoline by Truck." Final Report, Contract EY-76-C-06-1830, U.S. Department of Energy. Battelle Pacific Northwest Laboratory, Report PNL-2133, UC-71, November 1978.
5. Jindra, F. "Maneuverability of Trailer Trains." SAE Transactions, V. 71, 1963.
6. Isermann, H. "Overturning Limits of Articulated Vehicles with Solid and Liquid Loads. Motor Industry Research Assoc., Translation No. 58/70, 1970.
7. Verma, M.K. and Gillespie, T.D. "Roll Dynamics of Commercial Vehicles." Vehicle System Dynamics, 9, 1980, pp. 1-17.
8. MacAdam, C.C. "An Optimal Preview Control for Linear Systems." Journal of Dynamic Systems, Measurement, and Control, September 1980.
9. Strandberg, L. "Lateral Stability of Road Tankers." National Road & Traffic Research Institute, Sweden, NR 138A, 1978.
10. McLean, J.R. and Hoffmann, E.R. "The Effects of Restricted Preview on Driver Steering Control and Performance." Human Factors, 15(4), 1973, pp. 421-430.
11. "Review and Analysis of Gasoline Consumption in the United States from 1960 to the present." DOT-TSC-OST-74-43.
12. Michigan Department of State Police. "Michigan Traffic Accident Facts." 1973-78.

13. National Safety Council. "Accident Facts." 1976-79.
14. Kemp, R.N., Chinn, B.P., and Brock, G. "Articulated Vehicle Roll Stability: Methods of Assessment and Effects of Vehicle Characteristics." Transport and Road Research Laboratory, England, Report TRRL 788, 1978.
15. Strandberg, L., Nordstrom, O., and Nordmark, S. "Safety Problems in Commercial Vehicle Handling." Proceedings of a Symposium on Commercial Vehicle Braking and Handling, Highway Safety Research Institute, The University of Michigan, May 5-7, 1975, pp. 463-527.
16. Sweatman, P. "Research Needs in Articulated Vehicle Dynamics." Australian Road Research Board, 1977.
17. Roland, R.D. and Kunkel, D.T. "The Influence of Tire Properties on Passenger Vehicle Handling - Vol. V: Measured Tire Performance Data." Final Report, Contract No. DOT-HS-053-3-727, Calspan Corporation, Report No. ZM-5350-K-5, June 1974.