

PLAN VIEW DRILLED SHAFT FOR TYPE E CANTILEVERS

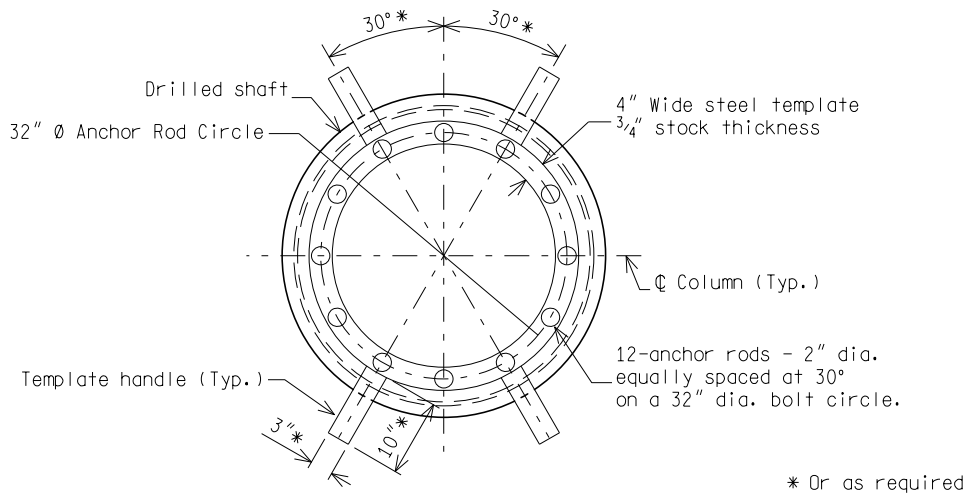

PLAN VIEW DRILLED SHAFT FOR TYPE E TRUSS 50' - 105'

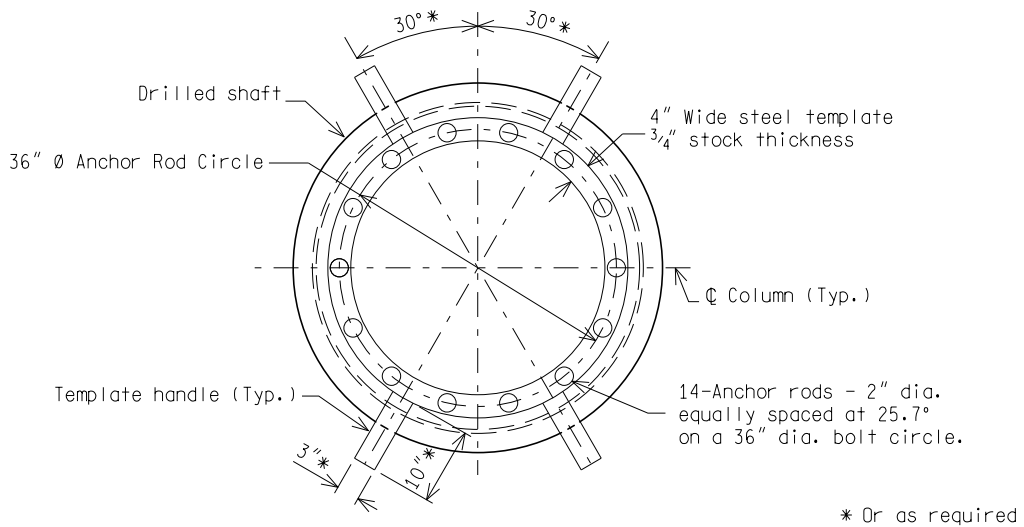

PLAN VIEW DRILLED SHAFT FOR TYPE E TRUSS 110' - 140'

NOT TO SCALE

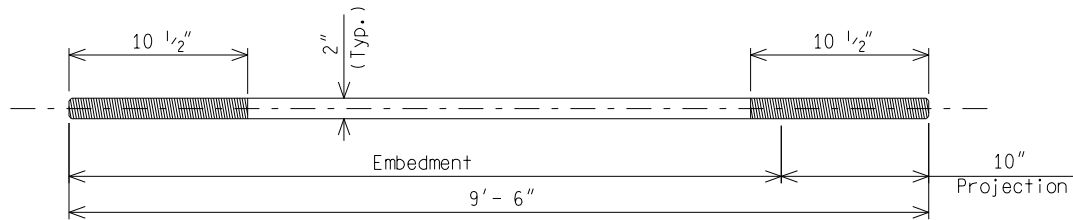

ANCHOR ROD DETAIL

ANCHOR ROD TABLE		
STRUCTURE TYPE	PROJECTION	NUMBER REQ'D
TYPE E CANTILEVER	10"	8
50' TO 105' TYPE E TRUSS	10"	12
110' TO 140' TYPE E TRUSS	10"	14

Nuts: 4 per anchor rod
Washers: 4 per anchor rod

NOTES:

1. Steel reinforcement shall be per Section 905 of the MDOT Standard Specifications for Construction.
2. Anchor rods, nuts and washers shall be per section 908.14 of the MDOT Standard Specifications for Construction.
3. A template and anchor rod cage shall be shop fabricated and assembled.
4. Diameter of bolt holes in template shall be $\frac{1}{16}$ " larger than anchor rod diameter.
5. The template and handles shall be well supported, horizontally level and firmly anchored in place a minimum of 24 hours after the concrete placement is completed.
6. Take care during concrete placement to avoid displacing the anchor rods. Concrete shall be in accordance with MDOT Standard Specifications For Construction, subsections 810.03.N.1 and 706.03.H.
7. No hammering on the anchor rods or template will be allowed.
8. After template is removed, thread nuts onto rod flush with the rod end to protect threads until sign support is erected.
9. V06 Anchor rod cage bar reinforcement shall meet the requirements of ASTM A706 if welded to anchor rods.
10. Top and bottom anchor rod templates may be fabricated from multiple parts using CJP welds located a minimum of 2" clear of anchor rod holes.

NOT TO SCALE

STEEL BAR REINFORCEMENT CHART

STRUCTURE TYPE	FOUNDATION DIAMETER (in)	VERTICAL REINFORCEMENT		CONFINEMENT REINFORCEMENT		
		BAR SIZE	NUMBER OF BARS	BAR RADIUS	BARS SIZE	BAR SPACING
TYPE E CANTILEVER	48	11	24	20 1/4"	6	6"
TYPE E TRUSS	48	11	36	20 1/4"	6	6"
	54	11	48	23 1/4"	6	6"
	72	11	57	32 1/4"	6	6"

See sheets 5 and 6 for foundation information.

Vertical reinforcement bars shall be bundled side by side, 3 bars per bundle all in the same plane. Provide a 9'-2" lap, stagger the ends of the individual bar laps by the amount of the lap length within each bundle.

Provide a 4'-8" lap for # 6 bar circles or a 12" lap if bar circle lap is welded.

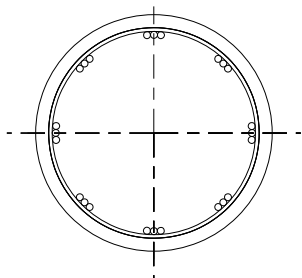

TYPE E CANTILEVER 48"

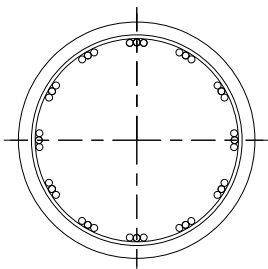

TYPE E TRUSS 48" DIAMETER

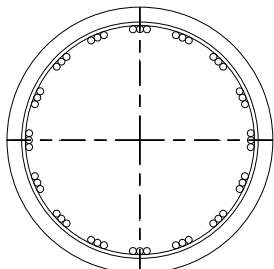

TYPE E TRUSS 54" DIAMETER

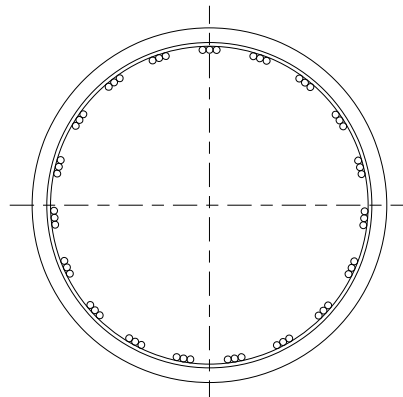

TYPE E TRUSS 72" DIAMETER

SECTION A-A (SHEET 1)

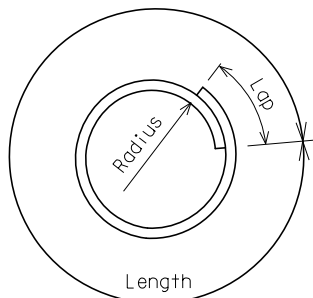

CONFINEMENT REINFORCEMENT

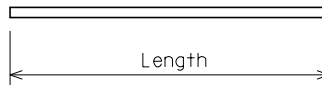

VERTICAL REINFORCEMENT

REINFORCEMENT DETAILS

NOT TO SCALE

MICHIGAN DEPARTMENT OF TRANSPORTATION

10/11/23
F.H.W.A. APPROVAL

08/08/23
PLAN DATE

SIGN-340-C

SHEET
4 OF 7

NON-CANTILEVER TRUSS FOUNDATION CHART

SPAN	SOIL TYPE	SOIL CONDITION		DIAMETER (in)	DEPTH "D" (ft)	CONCRETE (cyd)
		*Su	**N60			
50' TO 80'	LOW SAND	-	5 < N60 < 10	48	37	17.3
	MED SAND	-	10 < N60 < 20		35	16.3
	HIGH SAND	-	N60 > 20		32	14.9
	LOW CLAY	400 < Su < 1000	-	72***	54	56.6
	MED CLAY	1000 < Su < 2000	-	48	41	19.1
	HIGH CLAY	Su > 2000	-		32	14.9
85' TO 105'	LOW SAND	-	5 < N60 < 10	48	38	17.7
	MED SAND	-	10 < N60 < 20		36	16.8
	HIGH SAND	-	N60 > 20		34	15.9
	LOW CLAY	400 < Su < 1000	-	72***	59	61.8
	MED CLAY	1000 < Su < 2000	-	48	47	21.9
	HIGH CLAY	Su > 2000	-		37	17.3
110' TO 120'	LOW SAND	-	5 < N60 < 10	54	37	21.8
	MED SAND	-	10 < N60 < 20		34	20.1
	HIGH SAND	-	N60 > 20		31	18.3
	LOW CLAY	400 < Su < 1000	-	72***	62	65.0
	MED CLAY	1000 < Su < 2000	-	54	44	26.0
	HIGH CLAY	Su > 2000	-		30	17.7
125' TO 140'	LOW SAND	-	5 < N60 < 10	54	39	23.0
	MED SAND	-	10 < N60 < 20		36	21.3
	HIGH SAND	-	N60 > 20		35	20.7
	LOW CLAY	400 < Su < 1000	-	72***	65	68.1
	MED CLAY	1000 < Su < 2000	-	54	45	26.6
	HIGH CLAY	Su > 2000	-		32	18.9

* Su = Undrained shear strength of cohesive soils. (lbs/ft²)

** N60 = SPT blow count corrected for hammer efficiency (blows/ft)
(ASTM testing procedure D1586)

*** 72"Ø foundation provided for information only, site specific foundation

NOTE:

IF SOILS WITH SPT N60-VALUES GREATER THAN 50 BPF DOMINATE THE LOWER 1/2, OR MORE, OF A DRILLED SHAFT, OR IF ROCK SOCKETS FOR THE DRILLED SHAFTS ARE REQUIRED, THEN A DETAILED SITE SPECIFIC DESIGN FOR THE DRILLED SHAFT FOUNDATION IS REQUIRED.

NOT TO SCALE

MICHIGAN DEPARTMENT OF TRANSPORTATION

10/11/23
F.H.W.A. APPROVAL

08/08/23
PLAN DATE

SIGN-340-C

SHEET
5 OF 7

CANTILEVER FOUNDATION CHART

CANTILEVER TYPE	SOIL TYPE	SOIL CONDITION		DIAMETER (in)	DEPTH "D" (ft)	CONCRETE (cyd)
		*Su	**N60			
E	LOW SAND	-	5 < N60 < 10	48	31	14.5
	MED SAND	-	10 < N60 < 20		26	12.2
	HIGH SAND	-	N60 > 20		26	12.2
	LOW CLAY	400 < Su < 1000	-		44	20.5
	MED CLAY	1000 < Su < 2000	-		28	13.1
	HIGH CLAY	Su > 2000	-		20	9.4

*Su = Undrained shear strength of cohesive soils. (lbs/ft²)

**N60 = SPT blow count corrected for hammer efficiency (blows/ft)
(ASTM testing procedure D1586)

NOTE:

IF SOILS WITH SPT N60-VALUES GREATER THAN 50 BPF DOMINATE THE LOWER 1/2 OR MORE, OF A DRILLED SHAFT, OR IF ROCK SOCKETS FOR THE DRILLED SHAFTS ARE REQUIRED, THEN A DETAILED SITE SPECIFIC DESIGN FOR THE DRILLED SHAFT FOUNDATION IS REQUIRED.

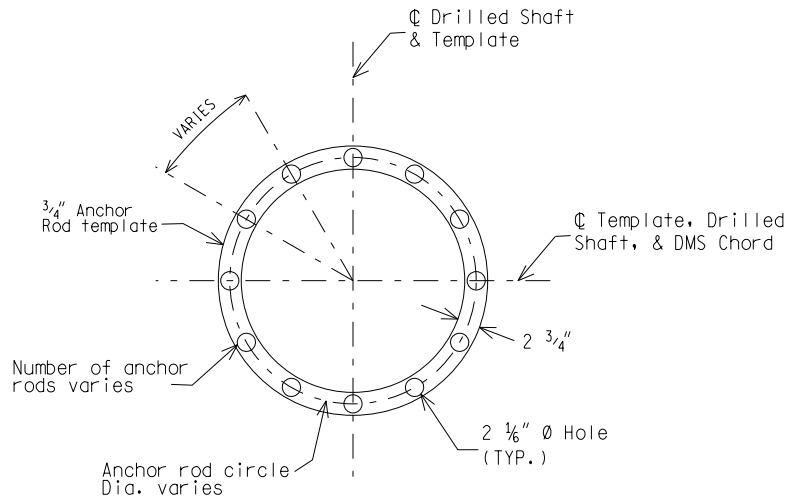

BOTTOM ANCHOR ROD TEMPLATE DETAIL

NOT TO SCALE

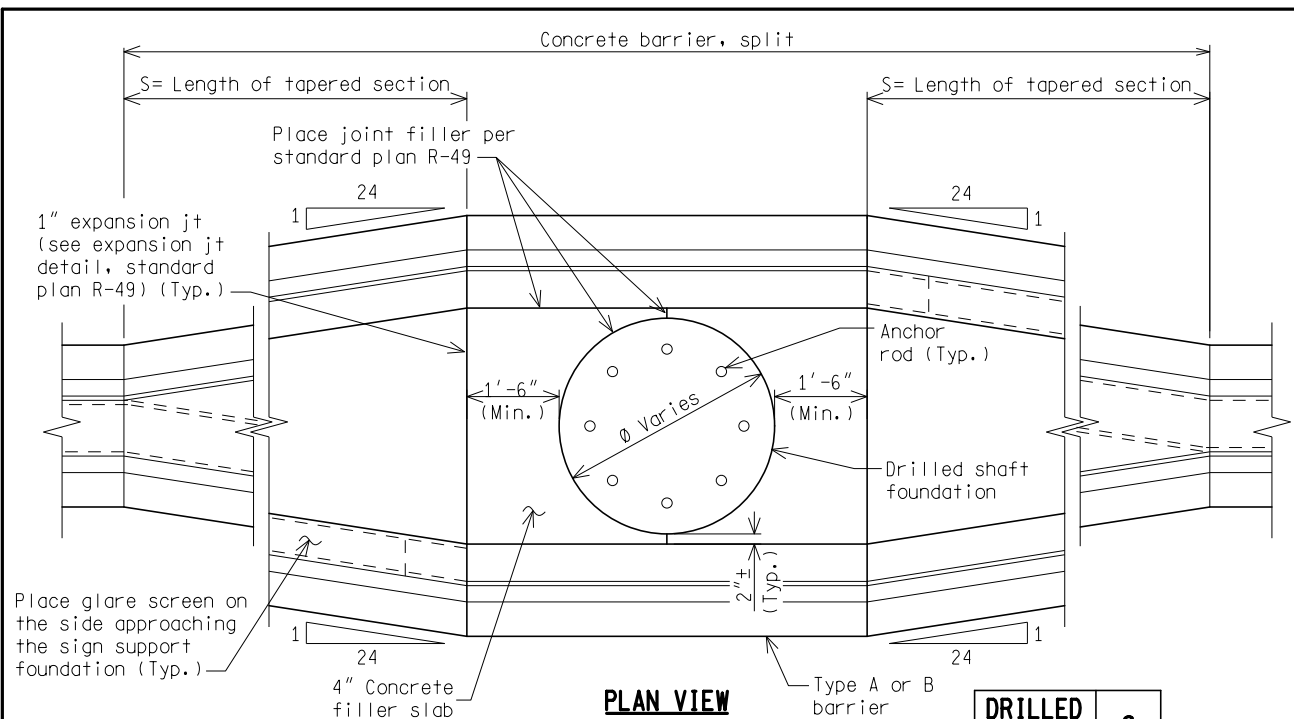

PLAN VIEW

DRILLED SHAFT Ø	S
48"	54'
60"	66'
72"	78'

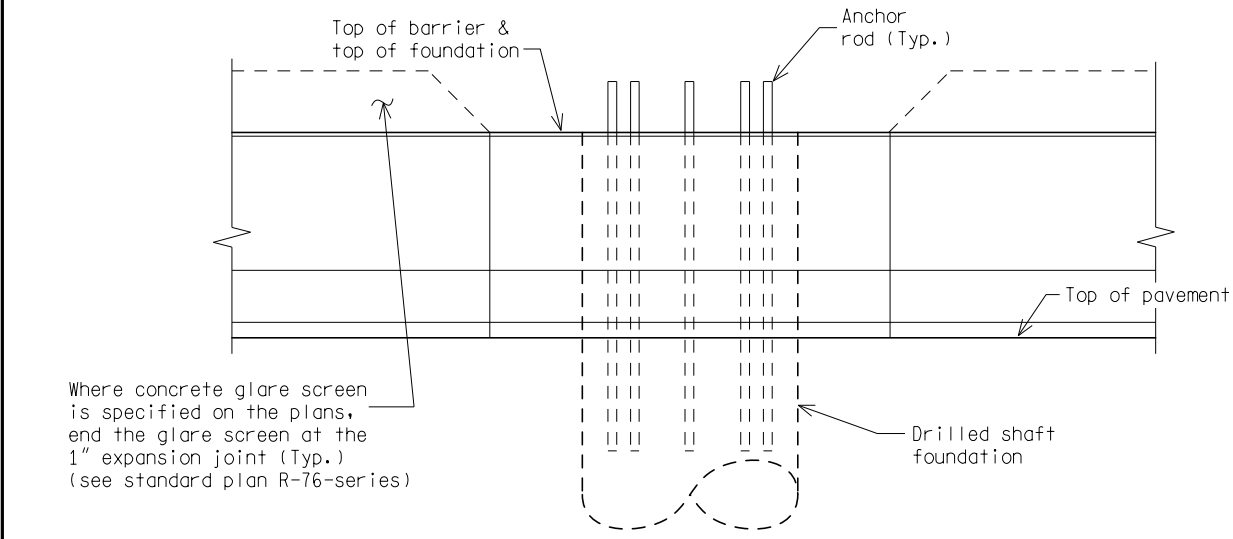

ELEVATION

MEDIAN BARRIER FOUNDATION DETAILS

NOTES:

When the foundation will be located within the median barrier, use standard plan R-49 series. Increase the foundation depth by the height of the barrier (not including the height of the glare screen if present) and locate the top of foundation at the top of barrier. Provide a parallel barrier section along the drilled shaft foundation.

Specific details vary depending on the use of Type A or Type B Barrier. For barrier details not shown see Standard Plan R-49.

NOT TO SCALE