

MICHIGAN  
DEPARTMENT OF TRANSPORTATION  
SPECIAL PROVISION  
FOR  
**PERMANENT TRAFFIC SIGNS AND SUPPORTS REVISIONS**

STR:MLO

1 of 5

APPR:MJF:REL:01-30-26

APPR:FHWA:02-02-26

**Delete subsection 810.03.N, shown on pages 8-46 through 8-49 of the Standard Specifications for Construction, in their entirety and replace with the following:**

**N. Anchor Bolts for Sign Support Structures.**

1. **Anchor Bolt Installation.** Place and hold anchor bolts plumb and aligned using a steel template. Secure the template before placing the concrete and leave in place at least 24 hours after concrete placement. Place concrete in accordance with 706.03.H and finish smooth and horizontal. Do not erect the sign support until the concrete attains 70% of the minimum 28-day compressive strength or until test beams or cylinders attain a flexural strength of 500 psi.
2. **Anchor Bolt Tightening.** Clean the anchor bolts, nuts, and flat washers using mineral spirits or naphtha to remove any contamination. Verify the nuts can be turned onto the anchor bolts past the elevation corresponding to the final leveling nut location and be backed off by the effort of one person using a 12-inch-long wrench (i.e., without employing a pipe extension on the wrench handle). Turn the leveling nuts onto the anchor bolts and align the top of the nuts to the same elevation using an instrument (bubble level, laser level, etc.) capable of providing an accuracy equal to or better than 0.0005 inches per inch. If a bubble level is used, it must be long enough to span from leveling nut to leveling nut in a crisscross/star pattern to ensure the top of all leveling nuts share a common plane.

Place a hardened washer on top of each leveling nut. The distance from the top of the concrete foundation to the bottom of all leveling nuts must not exceed 1 inch. Install the upright column and apply beeswax to the anchor bolt threads, top nut threads, and bearing surface between the top nut and top washer (see Figure 810-1). Re-apply beeswax if more than 24 hours has elapsed since initial application or if the components have become wet (e.g., rain, snow, or dew) since beeswax was applied. Place a hardened washer on each anchor bolt (top of the base plate) and turn the lubricated top nuts onto the lubricated anchor bolts.

Torque wrenches (hydraulic, click-style, or torque controllers used in conjunction with or built into power tools) must be calibrated on an annual basis. If there is reason to question the tool's accuracy and precision then the torque wrench must be re-calibrated as directed by the Engineer. Provide the Engineer with a copy of the accredited calibration certification for each torque wrench used. The Department has the right to witness calibration verification if there is a reason to question the accuracy of the torque wrench. Use a torque wrench with the drive size specified in Table 810-1 to ensure the torque being applied is in the middle half of the wrench's torque operating range for acceptable accuracy (e.g., 1/2 inch drive torque wrench with a 0 to 250 lbf-ft

torque range has an operating range of 65 to 185 lbf-ft). The torque wrench must be able to provide an audible noise or have a preset torque stop feature.

**a. Snug-Tight Condition.**

- i. Tighten the top nuts to a snug-tight condition following a star pattern (see Figure 810-2). Snug-tight is defined as the application of the specified torque shown in Table 810-1.
- ii. Apply one-half of the specified torque shown in Table 810-1 to the top nuts during the first tightening pass following a star pattern (Figure 810-2).
- iii. Tighten the bottom leveling nuts following a star pattern using effort (approximately 50 lbf-ft) to bring the bottom leveling nuts into firm contact with the base plate.
- iv. Apply the full specified torque shown in Table 810-1 to the top nuts during the second tightening pass following a star pattern (Figure 810-2).

**Table 810-1  
Snug-Tight Torque Values**

Anchor Bolt Diameter (inch)	Torque Wrench Drive (inch)	Snug-Tight Torque (lbf-ft)
3/4	1/2	60
1		70
1 1/4		80
1 1/2		120
1 3/4		80
2		100

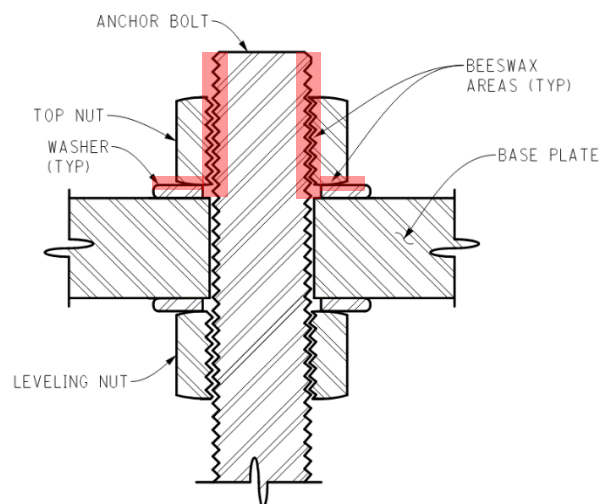

**Figure 810-1:** Lubrication areas are highlighted for anchor bolts, nuts, and washers.

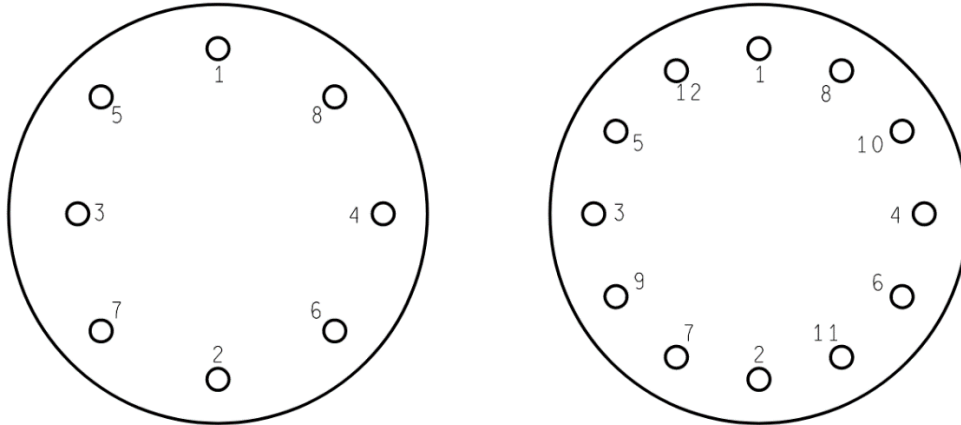

**Figure 810-2:** Examples of star pattern tightening sequence for 8 and 12 anchor bolt foundations. Foundations with a different number of anchor bolts must follow a similar tightening sequence.

**b. Turn-of-Nut (TON) Pretensioning.**

- i. Mark the reference position of each snug-tightened top nut using a permanent marker by connecting a line from the center of the anchor bolt to a corner of the nut flat and extending the line onto the base plate (see Figure 810-3). Draw TON marking lines at  $1/12$  and  $1/6$  rotations from the reference line. Repeat this TON marking process for each anchor bolt.
- ii. Turn the top nut for each anchor bolt to one half the required nut rotation beyond snug-tight ( $1/12$  turn) specified in Table 810-2 following a star pattern.
- iii. Turn the top nut for each anchor bolt the remaining required nut rotation (additional  $1/12$  turn to complete total  $1/6$  turn) following a star pattern.
- iv. Once the tightening is complete, the inspector and the wrench operator must mark the upright column with their initials and the date of tightening using a permanent marker.
- v. Perform a torque verification test on each top nut at least 10 minutes after the completion of the TON pretensioning process. The test must be performed in the presence of the Engineer using the applicable torque value shown in Table 810-3. The torque verification test passes if the top nut does not rotate when subjected (in the tightening direction) to the verification torque.

Notify the Engineer in writing of failing torque verification test(s). The Engineer will determine (based on the results of the torque verification test and objective evidence) if removal and retightening of the nut(s) is acceptable or if disassembly and re-erection of the structure will be required. All costs associated with correction must be performed at no additional cost to the Department.

The Department will ultrasonically test the anchor bolts for acceptance after a passing torque verification test. The ultrasonic testing and calibration procedures that are used by the Department for final structure acceptance are available upon request.

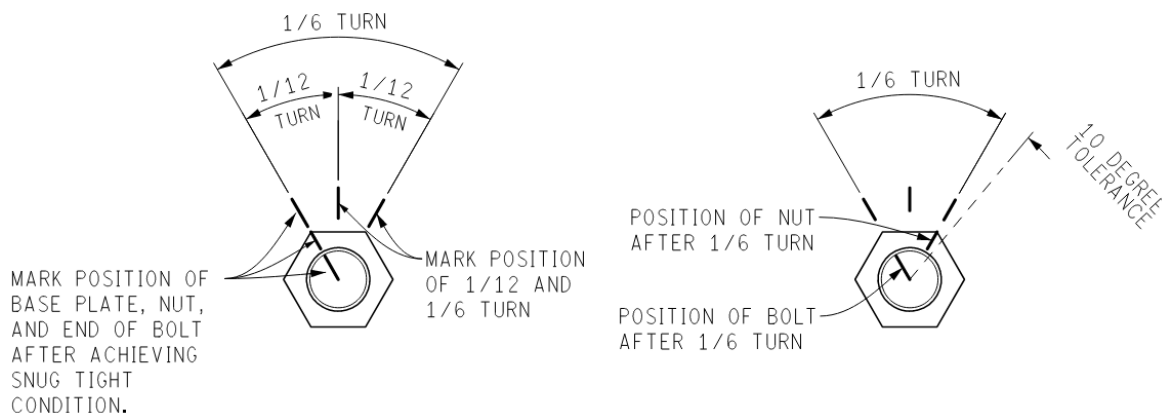

**Figure 810-3:** Example of TON match marking for 1/6 turn depicting initial 1/12 turn followed by final 1/12 turn and tightening tolerance.

**Table 810-2: Top Nut Rotation for Anchor Bolts TON Pretensioned**

Anchor Bolt Diameter (inch)	Nut Rotation Beyond Snug-Tight (a)(b)(c)
3/4, 7/8, 1, 1¼, 1½, 1¾, and 2	1/6 Turn

- Nut rotation is relative to anchor bolt. The tolerance is minus zero degrees plus 10 degrees (1/36 turn or 1/6 of a flat). See Figure 810-3 for more information.
- Applicable only to double-nut moment connections with anchor bolts meeting *ASTM F1554 Grades 55 and 105*, unified coarse thread series (UNC), and *ASME B1.1 Class 2A*. Nuts must meet *ASTM A563 Grade DH* or *ASTM A194 Grade 2H*, UNC, and *ASME B1.1 Class 2B*.
- Use a beveled washer if the nut is not in firm contact with the base plate or if the outer face of the base plate is sloped more than 1:40.

**Table 810-3: Torque Verification Test for Anchor Bolts TON Pretensioned**

Anchor Bolt Diameter (inch)	Verification Torque (a)(b) (lbf-ft)
3/4	80
7/8	130
1	200
1¼	400
1½	700
1¾	1100
2	1650

- Applicable only to double-nut moment connections with anchor bolts meeting *ASTM F1554 Grades 55 and 105*, unified coarse thread series (UNC), and *ASME B1.1 Class 2A*. Nuts must meet *ASTM A563 Grade DH* or *ASTM A194 Grade 2H*, UNC, and *ASME B1.1 Class 2B*.
- Verification torque for *Grades 55 and 105* was derived using the yield stress for *Grade 55*. Below is the verification torque equation and rounded up to the nearest 10 lbf - ft increment:

$$T_v = 0.12 * d_b * F_p / 12 \quad (\text{lbf - ft})$$

Where:

$d_b$  = nominal bolt diameter (inch)

$F_p$  = installation pretension (pound) ( $0.6 * \text{yield stress} * \text{tensile stress area}$ )

$A_t = \text{tensile stress area (in}^2\text{)} [(\pi / 4) * (d_b - (0.9743 / \text{thread pitch}))^2]$

- c. **Contractor Quality Control.** Contractor quality control is required to verify all anchor bolts are correctly pretensioned. The Contractor must have a designated quality control manager (QCM) actively complete MDOT Form 3595 *Contractor Quality Control Anchor Bolt Pretension Record* for each foundation during the entire anchor bolt tightening process. The QCM must have clearly defined authority and responsibility to take all actions and direct the Contractor's staff as necessary to ensure each anchor bolt is tightened as specified in subsection 810.N.2 of the Standard Specifications for Construction. The Contractor must provide the completed Form 3595 to the Engineer within 24 hours of the date covered by the record. The QCM must be a qualified and dedicated inspector that is overseeing the anchor bolt tightening operation and not involved with installation of the structure or anchor bolt tightening (i.e., the individual cannot quality control their own work).