

INSTRUCTIONS

IF, FOR EXAMPLE, YOU DESIRE TO KNOW WHAT RIGHT-OF-WAY THE M.D.S.H.&T. CONTROLS ACROSS ANY GIVEN AREA:

- 1- LOOK AT THE TITLE SHEET TO DETERMINE THE APPROPRIATE SHEET NUMBER BY FINDING THE PROPER SECTION NUMBER IN THE TOWN AND RANGE.
- 2- FIND THE PARCEL NUMBER AND READ THE DIMENSIONS.
- 3- FOR THE RECORDING DATA, SEE INFORMATION TO THE RIGHT OF PARCEL NUMBER IN THE RECORDING DATA BOX. THE LIBER & PAGE COLUMN REFERS TO THE COUNTY REGISTER OF DEEDS OFFICE.

ABBREVIATIONS

ADD.	-ADDITION	M.B.	-MONUMENT BOX
APP.	-APPROXIMATE	M.R.	-MISCELLANEOUS RECORDS
ASS' ORS	-ASSESSOR'S	P	-PERMIT
BD.	-BOUND	PL	-PROPERTY LINE
C.R.C.	-COUNTY ROAD COMMISSION	P.O.B.	-POINT OF BEGINING
CL	-CENTERLINE	P.O.E.	-POINT OF ENDING
C.C.	-CHANNEL CHANGE	PROJ.	-PROJECT
CONST.	-CONSTRUCTION	PROP.	-PROPOSED
COR.	-CORNER	P.V.	-CLEAR VISION
C.S.	-CONTROL SECTION	Q.C.	-QUIT CLAIM DEED
COMP.	-COMPUTED	R	-RANGE
D.	-DEED	RD.	-ROAD
DED.	-DEDICATED	RDWY.	-ROADWAY
DIS.	-CONDEMNATION DISCONTINUED	ROW	-RIGHT OF WAY
DR.	-DRIVE	REV.	-REVERTER CLAUSE
E.	-EASEMENT	R.R.	-RAILROAD
EX.	-EXISTING	SEC.	-SECTION
EX. R.O.W.	-EXISTING RIGHT-OF-WAY CLAIMED BY STATUTE	STA.	-STATION
FRACT. OR FRC'L	-FRACTIONAL	SUB.	-SUBDIVISION
GEN.	-GENERAL	SURV.	-SURVEY
G.L.O.	-GENERAL LAND OFFICE	TAN.	-TANGENT
HWY.	-HIGHWAY	T	-TOWN
INST.	-INSTRUMENT	T.J.	-TRANSFER OF JURISDICTION
L.A.	-LIMITED ACCESS	T.L.	-TRUNKLINE
L.C.	-LAND CONTRACT	TWP.	-TOWNSHIP
MAINT.	-MAINTENANCE		

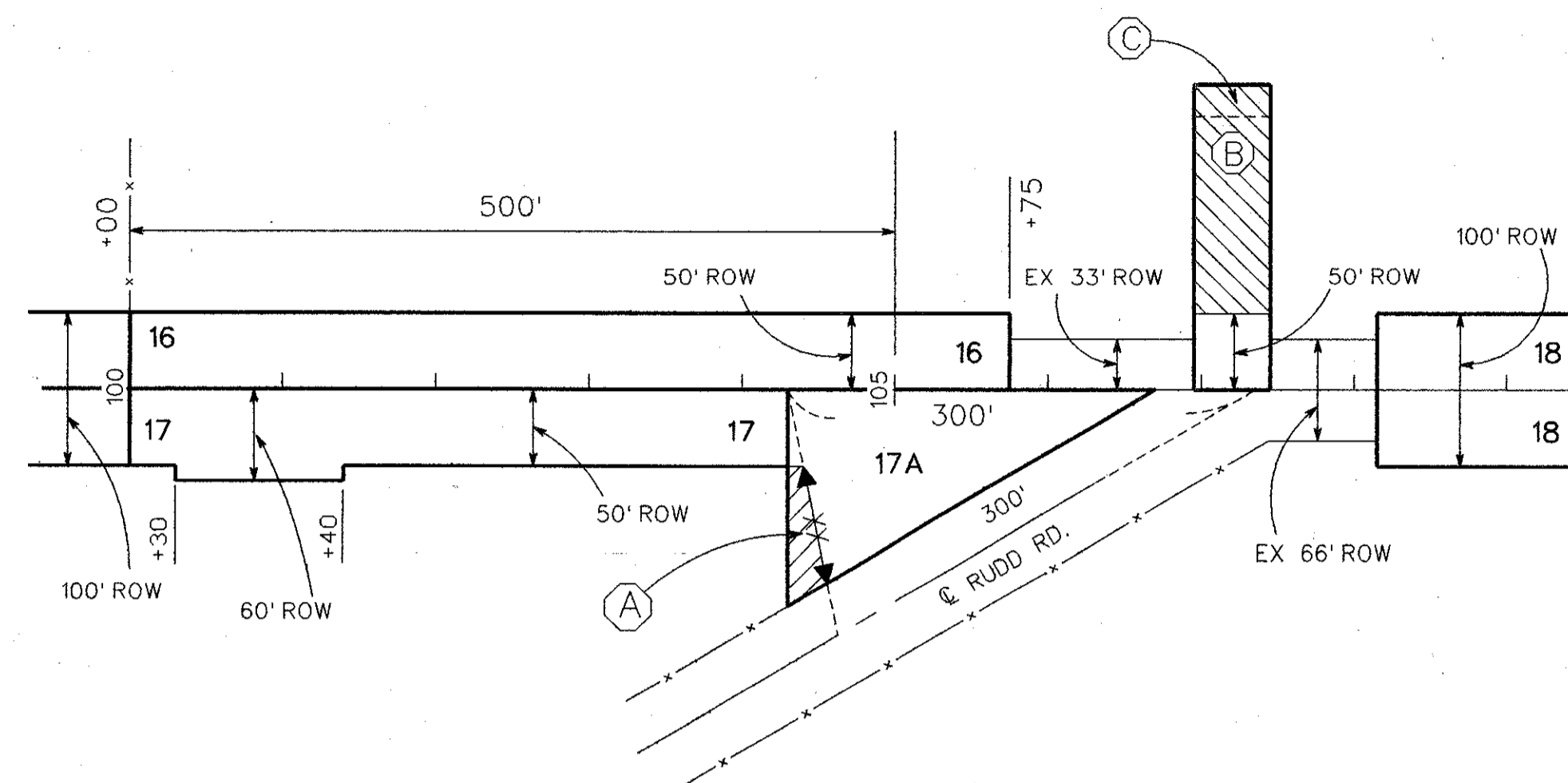

THE PROJECT OR CONTROL SECTION NUMBER IDENTIFIES THE THE GROUP OF NUMBERED PARCELS.

PARCEL	GRANTOR	INST.	DATE RECORDED	LIBER-PAGE	REV.
16	GEORGE MILLER	E	07-12-60	325-468	
C-17	JOHN BAKER	E	07-16-60	325-475	DIS.
17A	JOHN BAKER	D	08-01-60	326-34	LA
18	HENRY HANKS	E	12-15-35	15MR-105	

1. TYPE III ERROR

PARCEL	SOLD TO	INST.	DATE	SALE NO. & ITEM NO.	REV.
A	NAT TURNER	D	05-16-61	5-49-A-2	LA
B	SIMON GIRTY	D	06-14-38	5-14-N-1	LA&REV
C	JOHN MURRELL	E	01-18-55	5-22-A-3	

2. DRIVEWAY EASEMENT

ERROR IN DESCRIPTION SYMBOLS ARE DEFINED AS FOLLOWS:

- *-I. THE GRANTORS LEGAL DESCRIPTION OF RECORD IS IN ERROR.
- *-II. THE CENTERLINE DESCRIPTION ON WHICH ROW IS BASED IS IN ERROR, OR P.O.B. MIS-LOCATED.
- *-III. THE DESCRIPTION OF THE PARCEL TAKE IS IN ERROR.

HATCHED AREAS HAVE BEEN DISPOSED OF AS NOTED.

THE DISTANCE FROM STATION 100 TO STATION 105 IS 500 FEET. PARCEL 16 SHOWN ABOVE IS 575 FEET LONG (STATION 105+75 MINUS STATION 100+00 = 575 FEET).

PERPENDICULAR DISTANCES FROM THE CL TO R.O.W. LINES ARE SHOWN WITH THE SUFFIX R.O.W.. 100' R.O.W. AS SHOWN ABOVE DENOTES AN EQUAL DISTANCE OF 50' FROM THE CL TO EACH R.O.W. LINE.

PARCELS ARE SHOWN OUTLINED WITH HEAVY LINES, AND ARE NUMBERED.

DISTANCES ARE MEASURED FROM CL UNLESS OTHERWISE NOTED.

SYMBOLS

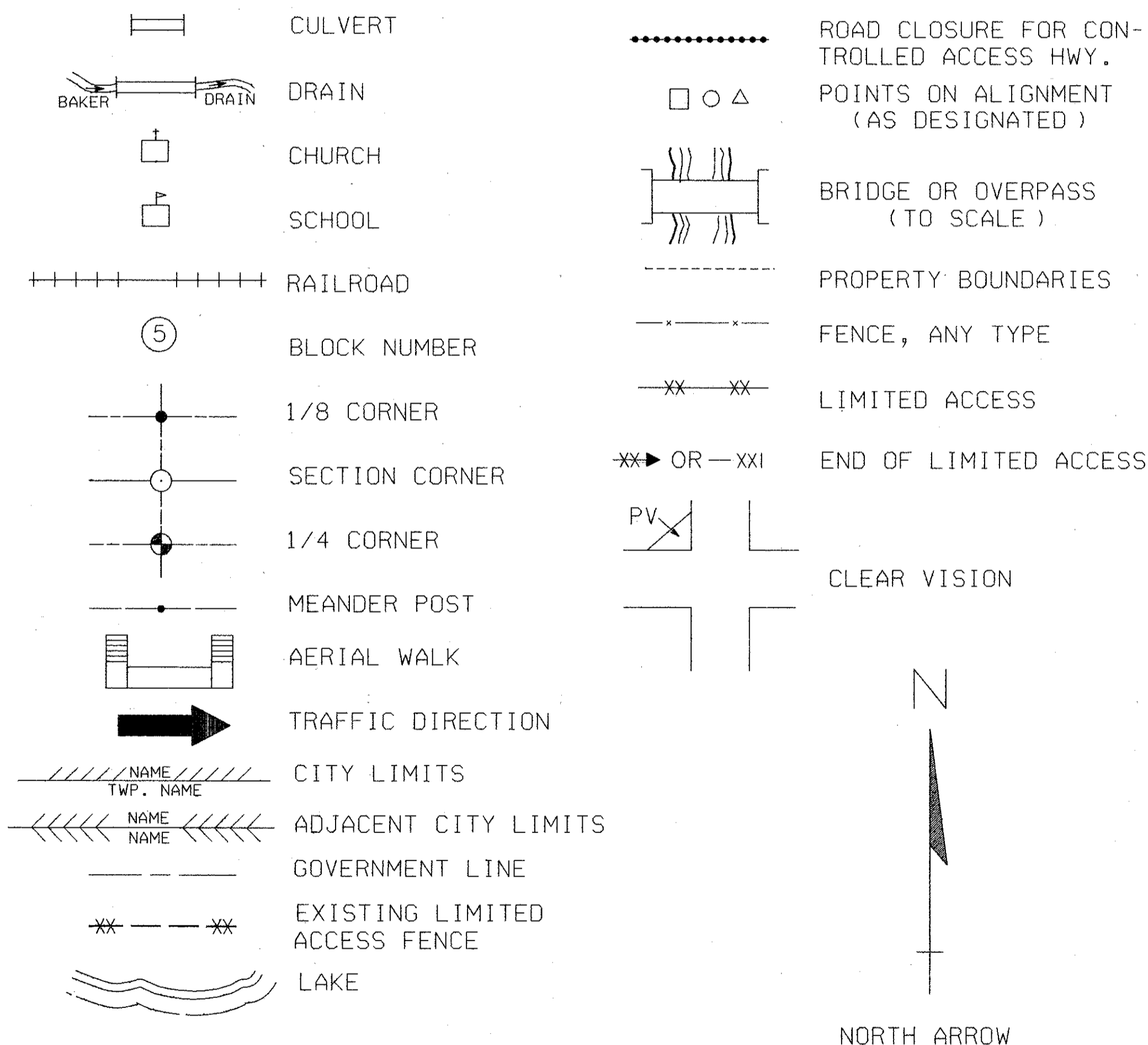

PLAN SCALES

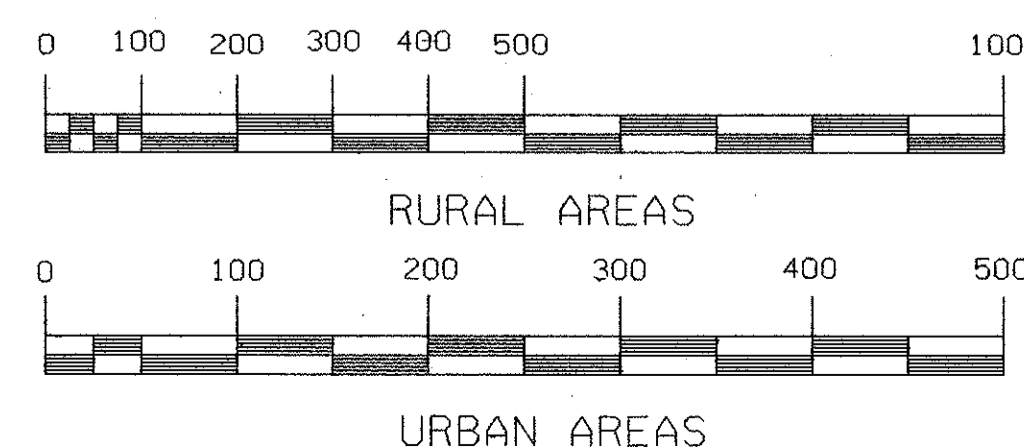

- CURVE DATA
- Δ = EXTERNAL ANGLE (DELTA)
 - D = DEGREE OF CURVE
 - R = RADIUS LENGTH
 - T = TANGENT LENGTH
 - E = EXTERNAL DISTANCE
 - L = LENGTH OF CURVE
 - PC = POINT OF CURVATURE
 - PI = POINT OF INTERSECTION
 - PT = POINT OF TANGENCY

VARIABLE R.O.W. -PERPENDICULAR DISTANCES FROM THE CL ARE INCONSISTENT

NOTE:

DEEDS COVERING THE SAME AREA AS AN EASEMENT IN WHOLE OR IN PART, SUPERSEDES EASEMENTS PARTIALLY OR COMPLETELY.

TO INQUIRE

ABOUT A PARTICULAR PARCEL, GIVE THE CONTROL SECTION AND/OR PROJECT NUMBER AND PARCEL NUMBER.

R.O.W. MAPS MAY BE ORDERED FROM:

MICHIGAN DEPT. OF TRANSPORTATION
 REAL ESTATE DIVISION
 MAPPING & RESEARCH
 P.O. BOX 30050
 LANSING MICH. 48909
 PHONE: 517 / 373-2140